

General Specifications

ROTAMASS 3 Series Coriolis Mass Flow and Density Meter

GS 01R04B04-00E-E



RCCT39/XR

RCCT34 - 39/IR

RCCF31 +
RCCS34 - 39/IR

RCCS30LR - 33

RCCR31

Contents	
Features	Page 1
Principle of measurement	Page 1
Performance specifications	Page 2
Normal operating conditions	Page 3
Mechanical specifications	Page 4
Remote cable specification	Page 5
Electrical specifications	Page 5
CE Declaration	Page 6
Hazardous area specifications	Page 7
Planning and installation hints	Page 12
Dimensions	Page 15
Model-, suffix- and option- codes	Page 23

ROTAMASS is a Coriolis mass flowmeter with highly refined digital signal processing electronics, so that accurate and stable mass flow measurement is achieved.

ROTAMASS employs a flame-proof type converter case suitable for use in the hazardous area together with its intrinsically safety type detector.

ROTAMASS's signal processing, housing protection and its detector's special decoupling system against external loads and vibrations, realize high performance in real applications.

PRINCIPLE OF MEASUREMENT

Mass flow measurement according to the Coriolis principle. For abrasive or highly corrosive fluids please contact your Yokogawa representative.



FEATURES

- ROTAMASS is a flowmeter for nearly all fluids, including high viscosity liquids, slurries and multi-phase media with a certain gas content
- Field-mount and rack-mount remote converter available
- Refined digital signal processing enables accurate and stable measurement
- A special detector decoupling system makes the device highly independent from external loads or vibrations.
- Simple flow path means self-draining, simple cleaning and suitable for use in hygienic industries.
- High accuracy and high stability over a wide flow range
- Accurate density measurement, up to $\pm 0.0005 \text{ g/cm}^3$
- Concentration measurement for solutions, suspensions and emulsions (e.g. water cut, net oil computing)
- Volume flow with reference density
- Temperature measurement
- Two analog outputs, two pulse outputs or status-out and one status-in as standard I/O
- Available in explosion proof versions (ATEX, FM, IECEx, EAC, INMETRO, NEPSI, KOSHA)
- European MID approval acc. OIML R-117-1 and American NTEP approval for Custody Transfer Measurement (see GS 01R04B07-00E-E)
- Wide process temperature range -200°C to 350°C
- Microprocessor-based multifunction capability
- EEPROM protects parameter settings and totalized values during power failure.
- High visible LCD display
- HART® communication function is available
- Optional Foundation™ Fieldbus communication is available (see GS 01R04B05-00E-E)
- Optional MODBUS® communication is available
- Optional intrinsically safe outputs are available
- Various choice of tubes materials
- EN, ASME or JIS flanges as standard, others on request
- FMEDA report on request, SIL 2, SIL 3 levels can be achieved if redundant meters are used.

■ PERFORMANCE SPECIFICATIONS

Model

- Remote detector RCCS30LR to 33: 2 tubes, low flow design
- Remote detector RCCS34 to 39/XR : 2 tube design
- Remote field-mount converter RCCF31
- Remote rack-mount converter RCCR31
- Integral type RCCT34 to 39/XR: 2 tube design

Fluid to be measured : Liquid, gas or slurry

Measurement Items : Mass flow, density, temperature and derived from these values: concentration, volume flow and net flow

Mass Flow Measurement

Table 1: measuring range

Model		RCCS30 LR	RCCS30	RCCS31	RCCS32	RCCS33
Qmax	t/h	0.04	0.094	0.3	0.6	1.5
	lb/h	88	207	661	1322	3307
Qnom	t/h	0.021	0.045	0.17	0.37	0.95
	lb/h	46	99	374	815	2094

Model		RCC□34	RCC□36	RCC□38	RCC□39	RCC□39 /IR	RCC□39 /XR
Qmax	t/h	5	17	50	170	300	600
	lb/h	11023	37478	110231	374785	661386	1322773
Qnom	t/h	3	10	32	100	250	500
	lb/h	6613	22046	70547	220462	551155	1102311

Qnom is the water flow rate at about 1 bar pressure drop. The flowmeter has a default low cut of 0.05% of Qnom.

Accuracy of mass flow (refer to table 2):

- Liquid RCCS30LR:
 - ± 0.15% of flow rate ± zero stability / flow rate *100%
- Liquid RCCS30 - 39/XR:
 - ± 0.1% of flow rate ± zero stability / flow rate *100%
- Gas (option /GA):
 - ± 0.5% of flow rate ± zero stability / flow rate *100%

Accuracy of volume flow :

$$\text{SQRT} ((\text{mass flow error in } \%)^2 + (\text{density error in } \%)^2)$$

Accuracy based on the frequency output includes the combined effects of repeatability, linearity and hysteresis.

Repeatability of liquids:

$$\pm 0.05\% \pm (\text{zero stability}/2) / \text{flow rate} *100\%$$

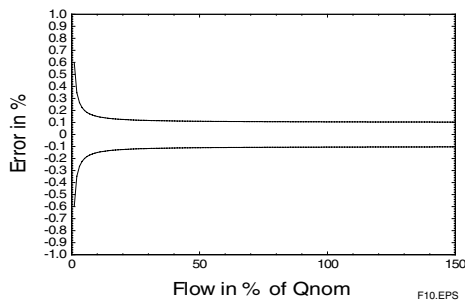

Table 2 : Zero stability

Model	RCCS30 LR	RCCS30	RCCS31	RCCS32	RCCS33
kg/h	0.003	0.005	0.0085	0.019	0.048
lb/h	0.006	0.011	0.018	0.04	0.105

Model	RCC□34	RCC□36	RCC□38	RCC□39	RCC□39 /IR	RCC□39 /XR
kg/h	0.15	0.5	1.6	5	13	25
lb/h	0.33	1.1	3.5	11	28.6	55

Pressure Dependency

The stiffness of the ROTAMASS tubes is slightly line pressure dependent. The static pressure effect of mass flow and density can be corrected by setting the static pressure manually via menu.

Table 3 : Static pressure effect on mass flow (if not corrected)

Model		RCCS30 LR	RCCS30	RCCS31	RCCS32	RCCS33
% of rate per bar / (psi)	SH	0.00000 / (0.0)	0.00000 / (0.0)	0.00012 / (0.00174)	0.00246 / (0.03568)	0.0035 / (0.0508)
	HC	----	----	----	----	----
Model		RCC□34	RCC□36	RCC□38	RCC□39	RCC□39 /IR
% of rate per bar / (psi)	SL	0.00081 / (0.01175)	0.00346 / (0.05018)	0.00950 / (0.1378)	0.01058 / (0.15345)	0.0047 / (0.0682)
	HC	0.00084 / (0.01218)	0.00336 / (0.04873)	0.00896 / (0.12995)	0.00808 / (0.11719)	0.00287 / (0.04163)
Model		RCC□39 /XR				
% of rate per bar / (psi)	SL	0.00740 / (0.1073)				
	HC	----				

Density Measurement

Adjustment with water and air at calibration temperature.

Measuring range:

- RCCS30LR - 38 : 0.3 kg/l to 5 kg/l
- RCC□39 - 39/XR : 0.3 kg/l to 2 kg/l

No density measurement for gas applications.

With option /K4 thermal stabilization is acquired.

For further details about the option /K6 please refer to "special calibrations" on page 3.

Calibration condition standard

- Density : 0.9 kg/l ≤ ρ ≤ 1.1 kg/l
- Temp. Fluid : 22.5°C ± 12.5°C
- Flow Rate : about 0.2 * Qnom as defined for each model

Calibration condition for /K6:

- Density : 0.7 kg/l ≤ ρ ≤ 1.65 kg/l
- Temp. Fluid : 20°C ≤ T ≤ 80°C
- Temp. Ambient : 20°C ± 3K
- Flow Rate : about 0.2 * Qnom as defined for each model

Table 4: Accuracy (at calibration conditions):

Type	Standard	Option /K4	Option /K6
RCCS30LR	0.02 g/cm³ *)	-----	-----
RCCS30	0.008 g/cm³ *)	-----	-----
RCCS31	0.004 g/cm³	0.001 g/cm³	-----
RCCS32	0.004 g/cm³	0.001 g/cm³	0.0005 g/cm³
RCCS33	0.004 g/cm³	0.001 g/cm³	0.0005 g/cm³
RCC□34	0.003 g/cm³	0.001 g/cm³	0.0005 g/cm³
RCC□36	0.0022 g/cm³	0.001 g/cm³	0.0005 g/cm³
RCC□38	0.0015 g/cm³	0.001 g/cm³	0.0005 g/cm³
RCC□39	0.0015 g/cm³	0.001 g/cm³	0.0005 g/cm³
RCC□39/IR	0.0015 g/cm³	-----	-----
RCC□39/XR	0.0015 g/cm³	-----	-----

*) 0.003 g/cm³ on request

Repeatability:

RCCS32-33, RCC□34-39/XR : ± 0.0005 g/cm³ (Std, /K4)

Static pressure effect:

Compensated if static pressure is set in the menu.

Specification of high performance density measurement option /K6: Density calibration

Density range : 0.3 to 2.5 kg/l
 Ambient temp. range : -10°C to 50°C (14°F to 122°F)
 Process temp. range Standard: -50°C to 150°C (58°F to 302°F)
 Process temp. range /HT: 150°C to 350°C (302°F to 662°F)
 Minimum flow rate for specified accuracy:
 - RCC□36 to RCC□39 : 700 kg/h (1543 lb/h)
 - RCC□34 : 140 kg/h (308 lb/h)
 - RCCS33 : 90 kg/h (198 lb/h)
 - RCCS32 : 37 kg/h (81 lb/h)
 Maximum flow rate : Q_{nom}
 Repeatability : $\pm 0.0002 \text{ g/cm}^3$
 Temperature measurement:
 $\pm(0.5^\circ\text{C} + 0.002 \cdot \text{abs}(T_{medium} - 20^\circ\text{C}))$ (not /HT)
 $\pm(0.5^\circ\text{C} + 0.008 \cdot \text{abs}(T_{medium} - 20^\circ\text{C}))$ (/HT)
 Density accuracy : only for liquids, one phase
 Process temperature influence :
 $\pm 0.000015 \text{ g/cm}^3 \cdot \text{abs}(T_{medium} - 20^\circ\text{C})$

Temperature Measurement

Temperature measuring range of converter :
 Standard, /LT, /MT : -200°C to 230°C (-328°F to 448°F)
 Option /HT : 0°C to 350°C (32°F to 662°F)

Accuracy:

Standard (-70°C to 150°C / -94°F to 302°F)
 : $\pm(0.5^\circ\text{C} + 0.005 \cdot \text{abs}(T_{medium} - 20^\circ\text{C}))$
 Option /LT (-200°C to 150°C / -328°F to 302°F)
 : $\pm(1.0^\circ\text{C} + 0.008 \cdot \text{abs}(T_{medium} - 20^\circ\text{C}))$
 Option /MT (-70°C to 260°C / -94°F to 500°F)
 : $\pm(0.5^\circ\text{C} + 0.005 \cdot \text{abs}(T_{medium} - 20^\circ\text{C}))$
 Option /HT (0°C to 350°C / 32°F to 662°F)
 : $\pm(1.0^\circ\text{C} + 0.008 \cdot \text{abs}(T_{medium} - 20^\circ\text{C}))$

For process temperatures more than 80°C (176°F) higher than ambient temperature the detector should be insulated to maintain optimum accuracy.

Heat Tracing

Heating with heat carrier, insulation and protection housing. Typically the max. surface temperature at the protection housing from inner heating is 40°C (at $T_{amb} = 20^\circ\text{C}$). Above 150°C (302°F) process temperature insulation from the manufacturer is recommended. However up to 230°C (446°F) process temperature the customer can insulate the detector himself. For this case order option /S2.

Option /T1 : only insulation and protection
 Option /T2 : insulation, protection and heating line
 Option /T3 : like /T2 but with ventilation

Process connection for the heat carrier fluid (see table 10):

for D-type flanges : EN DN 15 PN 40 Form B1
 for A-type flanges : ANSI 1/2" - 150 lbs.
 for J-type flanges : JIS DN15 10K

Max. pressure : PN 40

Protection class : IP54, install roof protected

For fluid temperatures below -70°C select option /LT.

Calibration for Liquids and Gases :

The ROTAMASS flow meters are always factory calibrated with water. Calibration Conditions:

- Water : $22.5^\circ\text{C} \pm 12.5^\circ\text{C}$ (72.5°F \pm 22.5°F)
 - Ambient temperature : $22.5^\circ\text{C} \pm 12.5^\circ\text{C}$ (72.5°F \pm 22.5°F)
 - Process pressure : 1 to 2 bar abs
 - Installation : RCCS30LR to RCC□38 vertical
 RCC□39 to RCCS□39/XR horizontal

All specifications are based on above mentioned calibration reference conditions, a flow calibration protocol is attached to each instrument.

Special Calibrations

- Mass-/Volume flow calibration with factory certificate (option /K2): Calibration with water at customer specified flow values according calibration order sheet.
- Mass-/Volume flow calibration with DAkkS certificate EN17025 (option /K5): Calibration with water at customer specified flow values according calibration order sheet.
- Density calibration with factory certificate (option /K6): Adjustment and check with 3 different fluids, fluid temperature influence adjustment for low ambient temperature influence and thermal treatment for long term density measurement stability, improved temperature measurement accuracy (see also page 12).

Dual Seal Approval (option /DS):

- Conform with ANSI/ISA-12.27.01.
- To be ordered if compliance with ANSI/ISA 12.27.01 is required.
- Up to ANSI class 900 line pressure.
- Only with FM approval option.
- For liquid application the leakage detection is realized by software in the converter.
- For gas application options /GA and /RD (rupture disk) are mandatory.
- Rupture disk is only for annunciation.

NORMAL OPERATING CONDITIONS

Ambient Temperature Ranges

- Remote detector RCCS3□:

Standard	: -50°C to +80°C (-58°F to 176°F)
Option /LT	: -50°C to +80°C (-58°F to 176°F)
Option /MT	: -50°C to +80°C (-58°F to 176°F)
Option /HT	: -50°C to +65°C (-58°F to 149°F)

 (up to 280°C (536°F) medium temperature)
 -50°C to +55°C (-58°F to 131°F)
 (up to 350°C (662°F) medium temperature)
 Terminal box temperature should not exceed 100°C
- Remote converter RCCF31, RCCR31 and integral type RCCT3□:

Display operating range	: -20°C to +55°C (-4°F to 131°F)
Electronic operating range	: -40°C to +55°C (-40°F to 131°F)
Cold start	: above -30°C (-22°F)

Where meters are mounted in direct sunlight, it is recommended to install a sunshade. This is particularly important in countries with high ambient temperatures.

Ambient Humidity Range : 0 to 95% RH

Process Temperature Ranges

- Detector :
- RCCS30LR to 33 : -50°C to 150°C (-58°F to 302°F)
 - RCCS30LR to 33 /MT : -50°C to 260°C (-58°F to 500°F)
 - RCCS34 to 39/XR : -70°C to 150°C (-94°F to 302°F)
 - RCCS34 to 39/XR /LT : -200°C to 150°C (-328°F to 302°F)
 - RCCS34 to 39/XR /MT : -70°C to 230°C (-94°F to 446°F)
 (Range 150°C - 230°C (302°F to 446°F) recommended with /T□ option)
 - RCCS34 to 39/IR /HT : 0°C to 350°C (32°F to 662°F)
 (only with /T□ option or with /S2 and customer insulation)
 - RCCS39/XR /HT : 0°C to 350°C (32°F to 662°F)
 (only with /S2 and customer insulation)
- Integral type :
- RCCT34 to 39/XR : -50°C to 150°C (-58°F to 302°F)

For use in hazardous area see "Hazardous Area Specifications"

Heat Carrier Fluid Temperature Ranges

- (Option /T2 or /T3 only for remote type RCCS30LR to 39/IR)
- Standard : 0°C to 150°C (32°F to 302°F)
 - With option /MT (RCCS30LR to 33):
0°C to 200°C (32°F to 392°F)
 - With option /MT (RCCS34 to 39/IR):
0°C to 230°C (32°F to 446°F)
 - With option /HT : 0°C to 350°C (32°F to 662°F)

Process Pressure Limit

In dependence of the process connections s. table 9.

On request following maximum pressure up to 27°C (RT=Room Temp.):

Material wetted parts	SH [bar] / (psi)	SL [bar] / (psi)	HC [bar] / (psi)
RCCS30LR	400 / (5801)	----	----
RCCS30	400 / (5801)	----	----
RCCS31	350 / (5076)	----	----
RCCS32	285 / (4183)	----	----
RCCS33	285 / (4183)	----	----
RCCS34 / RCCT34	----	260 / (3770)	385 / (5583)
RCCS36 / RCCT36	----	210 / (3045)	315 / (4568)
RCCS38 / RCCT38	----	175 / (2538)	260 / (3770)
RCCS39 / RCCT39	----	135 / (1958)	260 / (3770)
RCCS39/IR / RCCT39/IR	----	110 / (1595)	180 / (2610)
RCCS39/XR / RCCT39/XR	----	95 / (1377)	----

For higher medium temperatures maximum tube pressure needs to be derated as follows :

- up to 50°C (122°F) : 4% derating
- 51 to 100°C (123.8°F to 212°F) : 11% derating
- 101 to 150°C (213.8°F to 302°F) : 20% derating
- 151 to 230°C (303.8°F to 446°F) : 30% derating
- 231 to 350°C (447.8°F to 662°F) : 38% derating

Higher pressure on request.

The maximum process pressure of a single instrument is given by the lower value either of the process connections (table 9) or tubes. The maximum temperature and process pressure limits of an instrument are marked on the name plate as TS and PS.

The given temperature/pressure ranges are calculated and approved without corrosion or erosion effects. The customer is fully responsible of selecting proper materials which withstand corrosive or erosive conditions. In case of heavy corrosion and/or erosion the instrument may not withstand the pressure and an incident may happen with human and/or environmental harm. Yokogawa will not take any liability regarding damage caused by corrosion / erosion. If corrosion / erosion may happen, the user has to check periodically if the necessary wall thickness is still in place.

Gas Content Limits for Liquid / Gas Mixtures

Gas content limit is defined as the amount of gas in a liquid / gas mixture which generates an error in the converter. The gas content limit is dependent on viscosity, surface tension and bubble size of the liquid / gas mixture.

Furthermore it is highly flow rate dependent (the higher the flow rate, the lower the gas content limits). The stated values are for a flow of 50% of Q_{nom} and water / air without /HP:

Model	Gas content limit
RCCS30LR to RCCS32	no limitation
RCCS33 non-Ex type	no limitation
RCCS33 Ex type	approx. 35%
RCC□34	no limitation
RCC□36	approx. 50%
RCC□38	approx. 30%
RCC□39	approx. 7%
RCC□39/IR	approx. 3%
RCC□39/XR (with /HP)	approx. 2%

With option /HP the gas content limits are improved. With liquid/gas mixtures the specified mass flow accuracy will not be achieved.

For short time aeration a function can be activated to keep the current outputs constant during the aeration time.

Other 2 Phase Flow, liquid/solid and liquid/liquid

Two phase flow can generate minus span errors. The errors are proportional to the difference in density between the 2 phases and the amount of the second phase. If the particles or droplets are very small no errors will be generated.

Secondary Containment

Model	Typical rupture pressure	Option /J1 pressure test *)
RCCS30LR-33	65 bar / (942 psi)	---
RCC□34-36	120 bar / (1740 psi)	60 bar / (870 psi)
RCC□38	120 bar / (1740 psi)	40 bar / (580 psi)
RCC□39	80 bar / (1160 psi)	10 bar / (145 psi)
RCC□39/IR	50 bar / (725 psi)	---
RCC□39/XR	on request	---
RCC□39/XR/HT	50 bar / (725 psi)	---

*) Pressure test with safety factor S=1.1

If the detector housing is exposed to a pressure close to the rupture pressure it will deform and measurement will be strongly influenced. Therefore the pressure test of the housing (option /J1) can only be done as shown in above table.

MECHANICAL SPECIFICATIONS

Protection Class

- RCCT3□ : IP66/67
- RCCF31 : IP66/67
- RCCS3□ : IP66/67
- RCCR31 : IP20

Materials

- Detector housing : Stainless steel 304/1.4301
- Detector terminal box : 316L/1.4404
- Detector gas filling plug: 1.4305
- Detector insulation housing : Stainless steel 304/1.4301
- Detector rupture disk (/RD) : 316L
- Field- mount converter housing : Aluminium alloy with Polyurethane corrosion-resistant coating or epoxy coating (option /X1)
- Field- mount converter mounting bracket: : Stainless steel 304/1.4301
- Rack- mount converter housing : Aluminium
- Name plates : Stainless steel 304/1.4301

Coating Color

- Field-mount converter case : Mint green

Wetted Parts

- RCCS30LR to 33 :
Measuring tubes : Ni-Alloy C-22/2.4602
Process connections : 316L/1.4404
- RCC□34 to 39/IR :
Measuring tubes and process connection : 316L/1.4404/1.4435 or
Measuring tubes and flange face : Ni-Alloy C-22/2.4602
- RCC□39/XR :
Measuring tubes and process connection : 316L/1.4404/1.4435

Table 5 : Diameter of measuring tubes

Type		RCCS30 LR	RCCS30	RCCS31	RCCS32	RCCS33
Inner diameter	mm	0.9	1.2	2.1	3	4.5
	inches	0.035	0.047	0.083	0.118	0.177
Wall thickness	mm	0.15	0.2	0.25	0.25	0.4
	inches	0.006	0.008	0.009	0.009	0.016

Type		RCC□34	RCC□36	RCC□38	RCC□39	RCC□39 /IR	RCC□39 /XR
Inner diameter	mm	7.7	13.4	22.1	37.2	54.5	82.50
	inches	0.303	0.528	0.870	1.485	2.146	3.248
Wall thickness	mm	0.89	1.24	1.65	2.6	2.9	3.2
	inches	0.035	0.049	0.065	0.102	0.114	0.126

Chemical composition of wetted materials

316L/1.4404/1.4435 and Ni-Alloy C-22/2.4602 conform with

ANSI / NACE-MR0175 / ISO15156-2

ANSI / NACE-MR0175 / ISO15156-3

NACE MR0103

For details please see RYG's declaration about NACE conformity 8660001

Pressure Equipment Directive 2014/68/EU

Detectors comply with Directive 2014/68/EU on Pressure Equipment for fluid group 1 and 2.

Note: PED- compliance is not applicable for Rotamass assembled in the USA that are identifiable by nameplate containing "Assembled in USA with Foreign and Domestic Parts."

CRN : CRN 0F12074.5
Approved process connections see table 12

Vibration Test : Acc. IEC 60068-2-64

ELECTRICAL SPECIFICATIONS**Power Supply**

- AC- type : 90 V to 264 V AC
- AC- Ex-type : 90 V to 250 V AC
- DC- type : 20.5 V to 28.8 V DC
- Power consumption : max. 25 VA / 10 W
- External circuit breaker rating : 5 A, 250 V (The converter doesn't feature an installed power switch).

Fuse on Base Board

- AC- type : 2 A, T, breaking capacity 1500A
- DC- type : 2 A, T, breaking capacity 1500A

I/O Signals, including /KF1, /EF1, /UF1, /NF1, /GF1

- Two active current outputs: Iout1, Iout2
4 to 20 mA DC, galvanic separated from other signals,
Load resistance : 20 Ω to 600 Ω
Ambient temperature effect : < 0.05% of span/10°C
Linearity : 0.008 mA = 0.05% of span
Setting range URV for liquids:
-Qmax to + Qmax , Abs(URV-LRV) ≥ 5% of Qnom
Setting range URV for gases:
-Qmax to + Qmax , Abs(URV-LRV) ≥ 1% of Qnom
- Two pulse outputs / status outputs : Pout, Sout
Passive transistor contact output, 30 V DC, 200 mA
Output rate
Output 1 : 0 to 10000 pulses/s
Output 2 : 0 to 2000 pulses/s
Option /NM : passive, according EN 60947-5-6
Option /AP : active output, 12 V, 6 mA, R_i > 10 kΩ
Active pulse output is not isolated from current output 2
As frequency output
Output 1 : 20 Hz to 10000 Hz
Output 2 : 20 Hz to 2000 Hz
- Status input : Voltage-free contact
Closed : < 200 Ω
Open : > 100 kΩ

Option /KF5, /EF5, /UF5, /NF5, /GF5: 3 intrinsically safe outputs

- Two passive current outputs (additional power supply needed) : Iout1, Iout2, 4 to 20 mA DC, galvanically separated from other signals.
Supply voltage : 10.5 V to 30 V DC (without HART®), 165 mA
Supply voltage : 16.75 V to 30 V DC (with HART®), 165 mA
Load resistance : 20 Ω ... 600 Ω
Ambient temperature effect : < 0.05% of span/10°C
- One pulse output / status output : Pout
Passive transistor contact output, 30 V DC, 100 mA
Output rate : 0 to 2000 pulses/s
As frequency output : 20 Hz to 2000 Hz
- No status input

REMOTE CABLE RCCY03 SPECIFICATION

3 x Coaxial + 1 x 3 AWG20, shielded, twisted; overall shielding; flame propagation acc. IEC 60332-1.

We recommend to use only the original cable provided by Yokogawa. In case of local cable purchasing, please contact Yokogawa for specification.

Table 6 : Cable specifications

Model code	Temperature range	Wire gauge	Resistance of loop	Capacitance wire/wire	Capacitance wire/shield	Inductance wire/wire
RCCY031	-50 to +105°C -58°F to 221°F	Coaxial AWG 20	37 Ω/km 70 Ω/km	120 nF/km 145 nF/km	132 nF/km 290 nF/km	0.175 mH/km 0.70 mH/km
RCCY032	-50 to +105°C -58°F to 221°F	Coaxial AWG 20	37 Ω/km 70 Ω/km	120 nF/km 145 nF/km	132 nF/km 290 nF/km	0.175 mH/km 0.70 mH/km
RCCY033	-50 to +105°C -58°F to 221°F	Coaxial AWG 20	37 Ω/km 70 Ω/km	120 nF/km 145 nF/km	132 nF/km 290 nF/km	0.175 mH/km 0.70 mH/km
RCCY034	-50 to +105°C -58°F to 221°F	Coaxial AWG 20	37 Ω/km 70 Ω/km	120 nF/km 145 nF/km	132 nF/km 290 nF/km	0.175 mH/km 0.70 mH/km

Digital Communication

- HART® communication protocol rev. 5, superimposed on 4 -20 mA DC signal (Iout1)
 - Load resistance : 230 Ω to 600 Ω (including cable)
 - Power line spacing : >15 cm, avoid parallel wiring
 - Cable length : ≤ 2 km if „CEV” cables are used
- FOUNDATION™ Fieldbus communication (/FB)
 - see GS 01R04B05-00E
- MODBUS® communication (/MB2 + /MB3)
 - Physical interface RS485 as two wire data bus according EIA/TIA-485
 - Maximal bus length is depending from bus topology and communication speed.
 - Addresses: 1 to 247
 - Baud rates: 1200, 2400, 4800, 9600, 19200, 38400, 57600, 76800, 115200
 - Data formats: E/1, O/1, N/1, N/2 (parity/stop bits)
 - Modes: RTU, ASCII

Setting Functions

Parameter setting is possible by using the infrared switches on the display or with HART® communication. For comfortable setting we recommend to use Yokogawas Field Mate setting tool (DTM based).

The option /MB2 can be set via Modbus and display.

The option /MB3 can be set via Modbus, HART® and display.

Display Function

- Up to 4 lines.
- 4 selectable languages (English, German, French, Russian)
- Option /MB□ only available English

Damping Functions

The damping function is adjustable from 0 to 200 seconds and affects the display and outputs.

Isolation Resistance of Converter

When surge arrestors are removed

- between power and ground terminal: >100 MΩ / 500 V DC
- between power and I/O terminals : >20 MΩ / 100 V DC
- between I/O terminals and ground : >20 MΩ / 100 V DC

Dielectric Strength

When surge arrestors are removed

- between power and ground terminal : 1,500 V AC for 1 minute

Lightning Protection

Arresters 2000 A are inside of the converter for power supply lines.

■ CE DECLARATION

Pressure Equipment Directive 2014/68/EU

Detectors comply with Directive 2014/68/EU on Pressure Equipment for fluid group 1 and 2.

Note: PED- compliance is not applicable for Rotamass assembled in the USA that are identifiable by nameplate containing "Assembled in USA with Foreign and Domestic Parts."

Electromagnetic Compatibility

- Acc. IEC 61326-1: Class A, Table 2
 IEC 61326-2-3
 IEC 61000-3-2
 IEC 61000-3-3

Safety Requirement Standards

- Acc. IEC 61010-1
 IEC 61010-2-030
 Overvoltage category II
 Pollution degree 2

Intended use

Rotamass 3 series Coriolis mass flow and density meter is intended to measure mass flow of fluids and gases while simultaneously also capturing their density and temperature. Yokogawa is not liable for damages or penalties caused by use deemed contrary to the Intended Use of the product.

Rotamass 3 series Coriolis mass flow and density meter is a tailor-made product that is specifically designed to both be installed and function within:

- Large-scale fixed installations
- Means of transport for persons or goods, excluding electric two-wheel vehicles which are not type-approved

The EU Directive 2011/65/EU (RoHS II) does not apply to this product and is not part of its CE-Marking. This product must not be used beyond its Intended Use. Please consider the above if the intended installation location of your device is inside European Economic Area.

HAZARDOUS AREA SPECIFICATIONS

ATEX

Remote detector RCCS30LR ... 33 (Option /KS1):

- KEMA 01ATEX 1075 X
- Intrinsically safe
- II 2G Ex ib IIB/IIC T1 ... T6 Gb
- II 2D Ex ib IIIC Txxx Db
(xxx = max. surface temperature see below)
- Max. surface temperature :
 - Standard : 150°C (302°F)
 - /MT : 260°C (500°F)
- Degree of protection : IP66/67
- Ambient humidity : 0 to 95% RH
- Ambient temperature range : -50°C to +80°C (-58°F to 176°F)
- Process temperature limits :
 - Standard : -50°C to 150°C (-58°F to 302°F)
 - Option /MT : -50°C to 260°C (-58°F to 500°F)
- Heat carrier fluid temperature limits
 - Standard : 0°C to 150°C (32°F to 302°F)
 - Option /MT : 0°C to 200°C (32°F to 392°F)

Remote detector RCCS34 ... 39/XR (Option /KS1):

- KEMA 01ATEX 1075 X
- Intrinsically safe
- II 2G Ex ib IIB/IIC T1 ... T6 Gb
- II 2D Ex ib IIIC Txxx Db
(xxx = max. surface temperature see below)
- Max. surface temperature :
 - Standard + /LT : 150°C (302°F)
 - /MT : 220°C (500°F)
 - /HT : 350°C (662°F)
- Degree of protection : IP66/67
- Ambient humidity : 0 to 95% RH
- Ambient temperature range
 - Standard , option /LT and option /MT : -50°C to +80°C (-58°F to 176°F)
 - Option /HT (process temperature < 280°C (536°F) : -50°C to +65°C (-58°F to 149°F)
 - Option /HT (process temperature < 350°C (662°F) : -50°C to +55°C (-58°F to 131°F)
- Process temperature limits :
 - Standard : -50°C to 150°C (-58°F to 302°F)
 - Option /LT : -200°C to 150°C (-328°F to 302°F)
 - Option /MT : -50°C to 220°C (-58°F to 428°F)
 - Option /HT : 0°C to 350°C (32°F to 662°F)
- Heat carrier fluid temperature limits
 - Standard : 0°C to 150°C (-32°F to 302°F)
 - Option /MT : 0°C to 220°C (32°F to 428°F)
 - Option /HT : 0°C to 350°C (32°F to 662°F)

Remote converter RCCF31 (Option /KF1) :

- KEMA 02ATEX 2183 X
- Flame proof with Intrinsically safe connection to detector (ib)
- II 2G Ex d [ib] IIC T6 Gb or Ex d e [ib] IIC T6 Gb
- II 2G Ex d [ib] IIB T6 Gb or Ex d e [ib] IIB T6 Gb with option /HP
- II 2D Ex tb [ib] IIIC T75°C Db
- Max. surface temperature : 75°C (167°F)
- Degree of protection : IP66/67
- Power supply : 90 to 250 V AC, 50/60 Hz or 20.5 to 28.8 V DC
- Power consumption : max. 25 VA / 10 W
- Ambient humidity : 0 to 95% RH
- Ambient temperature range: -40°C to +55°C (-40°F to 131°F)

Remote converter RCCF31 (Option /KF5) :

- KEMA 02ATEX 2183 X
- Flame proof with Intrinsically safe connection to detector (ib)
- Additional Intrinsically safe outputs.
- II 2 (1) G Ex d [ia Ga] [ib] IIC T6 Gb or Ex d e [ia Ga] [ib] IIC T6 Gb
- II 2 (1) G Ex d [ia IIC Ga] [ib] IIB T6 Gb or Ex d e [ia IIC Ga] [ib] IIB T6 Gb with option /HP
- II 2 (1) D Ex tb [ia Da] [ib] IIIC T75°C Db
- Max. surface temperature : 75°C (167°F)
- Degree of protection : IP66/67
- Power supply : 90 to 250 V AC, 50/60 Hz or 20.5 to 28.8 V DC
- Power consumption : max. 25 VA / 10 W
- Ambient humidity : 0 to 95% RH
- Ambient temperature range: -40°C to +55°C (-40°F to 131°F)

Remote converter RCCR31 (Option /KS1) :

- KEMA 02ATEX 2183 X
- Associated apparatus with Intrinsically safe connection to detector (ib)
- II (2) G [Ex ib Gb] IIC
- II (2) G [Ex ib Gb] IIB with option /HP
- II (2) D [Ex ib Db] IIIC
- Power supply : 90 to 250 V AC, 50/60 Hz or 20.5 to 28.8 V DC
- Power consumption : max. 25 VA / 10 W
- Ambient humidity : 0 to 95% RH
- Ambient temperature range: -40°C to +55°C (-40°F to 131°F)



WARNING

Remote rack-mount converter RCCR31 must be installed in safe area !

Integral type RCCT34 ... 39/XR (Option /KF1) :

- KEMA 02ATEX 2183 X
- Flame proof with Intrinsically safe connection to detector (ib)
- II 2G Ex d ib IIC T6...T3 Gb or Ex d e ib IIC T6...T3 Gb
- II 2G Ex d ib IIB T6...T3 Gb or Ex d e ib IIB T6...T3 Gb with option /HP
- II 2D Ex ib tb IIIC T150°C Db
- Max. surface temperature : 150°C (302°F)
- Degree of protection : IP66/67
- Power supply : 90 to 250 V AC, 50/60 Hz or 20.5 to 28.8 V DC
- Power consumption : max. 25 VA / 10 W
- Ambient humidity : 0 to 95% RH
- Ambient temperature range: -40°C to +55°C (-40°F to 131°F)

Integral type RCCT34 ... 39/XR (Option /KF5) :

- KEMA 02ATEX 2183 X
- Flame proof with Intrinsically safe connection to detector (ib)
- Additional Intrinsically safe outputs.
- II 2 (1) G Ex d ib [ia Ga] IIC T6...T3 Gb or Ex d e ib [ia Ga] IIC T6...T3 Gb
- II 2 (1) G Ex d ib [ia IIC Ga] IIB T6...T3 Gb or Ex d e ib [ia IIC Ga] IIB T6...T3 Gb with option /HP
- II 2 (1) D Ex ib tb [ia Da] IIIC T150°C Db
- Max. surface temperature : 150°C (302°F)
- Degree of protection : IP66/67
- Power supply : 90 to 250 V AC, 50/60 Hz or 20.5 to 28.8 V DC
- Power consumption : max. 25 VA / 10 W
- Ambient humidity : 0 to 95% RH
- Ambient temperature range: -40°C to +55°C (-40°F to 131°F)
- Process temperature range : -50°C to 150°C (-58°F to 302°F)

Electrical data remote detector RCCS30LR ... 33 :

- Driving circuit : terminals D+ and D
 - Ex ib IIC : $U_i = 16\text{ V}$; $I_i = 53\text{ mA}$; $P_i = 0.212\text{ W}$
 $L_i = 4.2\text{ mH}$; $C_i = \text{negligible small}$
 - Ex ib IIB : $U_i = 16\text{ V}$; $I_i = 153\text{ mA}$; $P_i = 0.612\text{ W}$
 $L_i = 4.2\text{ mH}$; $C_i = \text{negligible small}$
- Sensor circuits: terminals S1+ and S1- or S2+ and S2-
 - Ex ib IIC : $U_i = 16\text{ V}$; $I_i = 80\text{ mA}$; $P_i = 0.32\text{ W}$
 $L_i = 4.2\text{ mH}$; $C_i = \text{negligible small}$
- Temperature sensor circuit : terminals TP1, TP2, TP3
 - Ex ib IIC : $U_i = 16\text{ V}$; $I_i = 50\text{ mA}$; $P_i = 0.2\text{ W}$
 $L_i = \text{negligible small}$; $C_i = \text{negligible small}$

Electrical data remote detector RCCS34 ... 39/XR :

- Driving circuit : terminals D+ and D
 - Ex ib IIC : $U_i = 16\text{ V}$; $I_i = 53\text{ mA}$; $P_i = 0.212\text{ W}$
 $L_i = 3.2\text{ mH}$; $C_i = \text{negligible small}$
 - Ex ib IIB : $U_i = 16\text{ V}$; $I_i = 153\text{ mA}$; $P_i = 0.612\text{ W}$
 $L_i = 3.2\text{ mH}$; $C_i = \text{negligible small}$
- Sensor circuits: terminals S1+ and S1- or S2+ and S2-
 - Ex ib IIC : $U_i = 16\text{ V}$; $I_i = 80\text{ mA}$; $P_i = 0.32\text{ W}$
 $L_i = 2.1\text{ mH}$; $C_i = \text{negligible small}$
- Temperature sensor circuit : terminals TP1, TP2, TP3
 - Ex ib IIC : $U_i = 16\text{ V}$; $I_i = 50\text{ mA}$; $P_i = 0.2\text{ W}$
 $L_i = \text{negligible small}$; $C_i = \text{negligible small}$

Electrical data remote converter RCCF31, RCCR31 and Converter of integral type RCCT3 :

- Driving circuit : terminals D+ / D-
 - Ex [ib] IIC : $U_o = 14.5\text{ V}$; $I_o = 47\text{ mA}$; $P_o = 0.171\text{ W}$
 $L_o = 15\text{ mH}$; $C_o = 0.65\text{ }\mu\text{F}$
 - Ex [ib] IIB : $U_o = 11.7\text{ V}$; $I_o = 124\text{ mA}$; $P_o = 0.363\text{ W}$
 $L_o = 8\text{ mH}$; $C_o = 10.3\text{ }\mu\text{F}$
- Sensor circuits: terminals S1+ / S1- or S2+ / S2-
 - Ex [ib] IIB/IIC : $U_o = 14.5\text{ V}$; $I_o = 47\text{ mA}$; $P_o = 0.171\text{ W}$
Ex [ib] IIC : $L_o = 15\text{ mH}$; $C_o = 0.65\text{ }\mu\text{F}$
Ex [ib] IIB : $L_o = 60\text{ mH}$; $C_o = 4.07\text{ }\mu\text{F}$
- Temperature sensor circuit : terminals TP1, TP2, TP3
 - Ex [ib] IIB/IIC : $U_o = 13.3\text{ V}$; $I_o = 40\text{ mA}$; $P_o = 0.133\text{ W}$
Ex [ib] IIC : $L_o = 20\text{ mH}$; $C_o = 0.91\text{ }\mu\text{F}$
Ex [ib] IIB : $L_o = 80\text{ mH}$; $C_o = 5.6\text{ }\mu\text{F}$
- Current outputs (only option /KF5) :
 - Ex ia IIC : $U_i = 30\text{ V}$; $I_i = 300\text{ mA}$; $P_i = 1.25\text{ W}$
 $L_i = 4\text{ }\mu\text{H}$; $C_i = 5.5\text{ nF}$
- Pulse output (only option /KF5) :
 - Ex ia IIC : $U_i = 30\text{ V}$; $I_i = 300\text{ mA}$; $P_i = 1.25\text{ W}$
 $L_i = 4\text{ }\mu\text{H}$; $C_i = 13.1\text{ nF}$

For temperature classification see table 7.

FM (For USA and Canada)**Remote detector RCCS30LR ... 39/XR (Option /FS1) :**

- Intrinsically safe
- AEx ia IIC, Class 1, Zone 0
- IS Class I, Division 1, Groups A, B, C, D T6
- DIP Class II / III, Division 1, Groups E, F, G
- IP67 / NEMA 4X
- Ambient temperature range : -50°C to $+80^\circ\text{C}$ (-58°F to 176°F)

Remote converter RCCF31 (Option /FF1, /FF5) :

- Housing explosion proof
- Provides Intrinsically safe detector circuits
- AEx d [ia] IIC, Class I, Zone 1, T6
- AEx d [ia] IIB, Class I, Zone 1, T6 with option /HP
- Class I, Division 1, Groups A, B, C, D
- Class I, Division 1, Groups C, D with option /HP
- Class II / III, Division 1, Groups E, F, G
- AIS Class I / II / III, Division 1, Groups A, B, C, D, E, F, G
- AIS Class I / II / III, Division 1, Groups C, D, E, F, G with /HP
- IP67 / NEMA 4X
- Ambient temperature range : -40°C to $+50^\circ\text{C}$ (-40°F to 122°F)

Remote converter RCCR31 (Option /FS1) :

- Intrinsically safe associated apparatus
- Provides Intrinsically safe detector circuits
- [AEx ia] IIC, Class I, Zone 1
- [AEx ia] IIB, Class I, Zone 1, T6 with option /HP
- AIS Class I, Division 1, Groups A, B, C, D
- AIS Class I, Division 1, Groups C, D with option /HP
- Ambient temperature range : -40°C to $+50^\circ\text{C}$ (-40°F to 122°F)

Integral type RCCT34 ... 39/XR (Option /FF1, /FF5) :

- Housing explosion proof
- AEx d [ia] IIC, Class I, Zone 1, T6
- AEx d [ia] IIB, Class I, Zone 1, T6 with option /HP
- Class I, Division 1, Groups A, B, C, D
- Class I, Division 1, Groups C, D with option /HP
- Class II / III, Division 1, Groups E, F, G
- IP67 / NEMA 4X
- Ambient temperature range : -40°C to $+50^\circ\text{C}$ (-40°F to 122°F)

Process temperature range :

- Standard : -50°C to 150°C / (-58°F to 302°F)
- with option /LT : -200°C to 150°C / (-328°F to 302°F)
- with option /MT (RCCS30LR...33) : -50°C to 260°C / (-58°F to 500°F)
- with option /MT (RCC34...39/XR) : -50°C to 220°C / (-58°F to 428°F)
- with option /HT : 0°C to 350°C / (-32°F to 662°F)

Heat carrier fluid temperature range :

- Standard : 0°C to 150°C / 32°F to 302°F
- with option /MT (RCCS30LR...33) : -50°C to 200°C (-58°F to 392°F)
- with option /MT (RCC34...39/XR) : -50°C to 220°C (-58°F to 428°F)
- with option /HT : 0°C to 350°C (32°F to 662°F)

Electrical data remote converter RCCF31, RCCR31 and Converter of Integral Type RCCT3□ :

- Driving circuit : terminals D+ / D-
Uo = 14.5 V; Io = 47 mA; Po = 0.171 W
Lo = 15 mH; Co = 0.65 µF
- Driving circuit : terminals D+ / D- with option /HP
Uo = 11.7 V; Io = 124 mA; Po = 0.363 W
Lo = 8 mH; Co = 10.3 µF
- Sensor circuits: terminals S1+ / S1- or S2+ / S2-
Uo = 14.5 V; Io = 47 mA; Po = 0.171 W
Lo = 15 mH; Co = 0.65 µF
- Temperature sensor circuit : terminals TP1, TP2, TP3
Uo = 13.3 V; Io = 40 mA; Po = 0.133 W
Lo = 20 mH; Co = 0.91 µF

Electrical data remote detector RCCS30LR ... 33 :

- Driving circuit : terminals D+ and D
Groups A-D: Ui = 16 V; Ii = 53 mA; Pi = 0.212 W
Li = 4.2 mH; Ci = negligible small
Groups C,D: Ui = 16 V; Ii = 153 mA; Pi = 0.612 W
Li = 4.2 mH; Ci = negligible small
- Sensor circuits: terminals S1+ and S1- or S2+ and S2-
Ui = 16 V; Ii = 80 mA; Pi = 0.32 W
Li = 4.2 mH; Ci = negligible small
- Temperature sensor circuit : terminals TP1, TP2, TP3
Ui = 16 V; Ii = 50 mA; Pi = 0.2 W
Li = negligible small; Ci = negligible small

Electrical data remote detector RCCS34 ... 39/XR :

- Driving circuit : terminals D+ and D
Groups A-D: Ui = 16 V; Ii = 53 mA; Pi = 0.212 W
Li = 3.2mH; Ci = negligible small
Groups C,D: Ui = 16 V; Ii = 153 mA; Pi = 0.612 W
Li = 3.2mH; Ci = negligible small
- Sensor circuits: terminals S1+ and S1- or S2+ and S2-
Ui = 16 V; Ii = 80 mA; Pi = 0.32 W
Li = 2.1 mH; Ci = negligible small
- Temperature sensor circuit : terminals TP1, TP2, TP3
Ui = 16 V; Ii = 50 mA; Pi = 0.2 W
Li = negligible small; Ci = negligible small

The remote converter RCCF31 has a T6 temperature class rating for operation at ambient temperature up to +50°C / +122°F.

Special conditions :

- ROTAMASS with FM approval is only available with ANSI 1/2" NPT cable conduit connection "A"
- The flowmeter must be connected to the potential equalization system.
- For AC-version maximum power supply is 250V AC.
- Use conduit seals within 18 inches for power supply- and IO- cable entries at RCCT3□ / RCCF31.

For temperature classification see table 7.

IECEX APPROVAL

Certificate: IECEx KEM 06.0031X

Remote detector RCCS30LR ... 33 (Option /ES1):

- Intrinsically safe
- Ex ib IIB/IIC T1 ... T6 Gb
- Ex ib IIIC Txxx Db
(xxx = max. surface temperature see below)
- Max. surface temperature :
Standard : 150°C (302°F)
/MT : 260°C (500°F)
- Degree of protection : IP66/67
- Ambient humidity : 0 to 95% RH
- Ambient temperature range : -50°C to +80°C (-58°F to 176°F)
- Process temperature range :
Standard : -50°C to 150°C (-58°F to 302°F)
Option /MT : -50°C to 260°C (-58°F to 500°F)
- Heat carrier fluid temperature range
Standard : 0°C to 150°C (32°F to 302°F)
Option /MT : 0°C to 200°C (32°F to 392°F)

Remote detector RCCS34 ... 39/XR (Option /ES1):

- Intrinsically safe
- Ex ib IIB/IIC T1 ... T6 Gb
- Ex ib IIIC Txxx Db
(xxx = max. surface temperature see below)
- Max. surface temperature :
Standard + /LT : 150°C (302°F)
/MT : 220°C (500°F)
/HT : 350°C (662°F)
- Degree of protection : IP66/67
- Ambient humidity : 0 to 95% RH
- Ambient temperature range
Standard , option /LT and option /MT : -50°C to +80°C (-58°F to 176°F)
Option /HT (process temperature < 280°C (536°F) : -50°C to +65°C (-58°F to 149°F)
Option /HT (process temperature < 350°C (662°F) : -50°C to +55°C (-58°F to 131°F)
- Process temperature range :
Standard : -50°C to 150°C (-58°F to 302°F)
Option /LT : -200°C to 150°C (-328°F to 302°F)
Option /MT : -50°C to 220°C (-58°F to 428°F)
Option /HT : 0°C to 350°C (32°F to 662°F)
- Heat carrier fluid temperature range
Standard : 0°C to 150°C (32°F to 302°F)
Option /MT : 0°C to 220°C (32°F to 428°F)
Option /HT : 0°C to 350°C (32°F to 662°F)

Remote converter RCCF31 (Option /EF1) :

- Flame proof with Intrinsically safe connection to detector (ib)
- Ex d [ib] IIC T6 Gb or Ex d e [ib] IIC T6 Gb
- Ex d [ib] IIB T6 Gb or Ex d e [ib] IIB T6 Gb
with option /HP
- Ex tb [ib] IIIC T75°C Db
- Max. surface temperature : 75°C (167°F)
- Degree of protection : IP66/67
- Power supply : 90 to 250 V AC, 50/60 Hz or 20.5 to 28.8 V DC
- Power consumption : max. 25 VA / 10 W
- Ambient humidity : 0 to 95% RH
- Ambient temperature range: -40°C to +55°C (-40°F to 131°F)

Remote converter RCCF31 (Option /EF5) :

- Flame proof with intrinsically safe connection to detector (ib)
- Additional Intrinsically safe outputs.
- Ex d [ia Ga] [ib] IIC T6 Gb or
Ex d e [ia Ga] [ib] IIC T6 Gb
- Ex d [ia IIC Ga] [ib] IIB T6 Gb or
Ex d e [ia IIC Ga] [ib] IIB T6 Gb with option /HP
- Ex tb [ia Da] [ib] IIIC T75°C Db
- Max. surface temperature : 75°C (167°F)
- Degree of protection : IP66/67
- Power supply : 90 to 250 V AC, 50/60 Hz or
20.5 to 28.8 V DC
- Power consumption : max. 25 VA / 10 W
- Ambient humidity : 0 to 95% RH
- Ambient temperature range: -40°C to +55°C (-40°F to 131°F)

Remote converter RCCR31 (Option /ES1) :

- Associated apparatus with Intrinsically safe connection to detector (ib)
- [Ex ib Gb] IIC
- [Ex ib Gb] IIB with option /HP
- [Ex ib Db] IIIC
- Power supply : 90 to 250 V AC, 50/60 Hz or
20.5 to 28.8 V DC
- Power consumption : max. 25 VA / 10 W
- Ambient humidity : 0 to 95% RH
- Ambient temperature range: -40°C to +55°C (-40°F to 131°F)

**WARNING**

Remote rack-mount converter RCCR31 must be installed in safe area !

Integral type RCCT34 ... 39/XR (Option /EF1) :

- Flame proof with Intrinsically safe connection to detector (ib)
- Ex d ib IIC T6...T3 Gb or
Ex d e ib IIC T6...T3 Gb
- Ex d ib IIB T6...T3 Gb or
Ex d e ib IIB T6...T3 Gb with option /HP
- Ex ib tb IIIC T150°C Db
- Max. surface temperature : 150°C (302°F)
- Degree of protection : IP66/67
- Power supply : 90 to 250 V AC, 50/60 Hz or
20.5 to 28.8 V DC
- Power consumption : max. 25 VA / 10 W
- Ambient humidity : 0 to 95% RH
- Ambient temperature range: -40°C to +55°C (-40°F to 131°F)

Integral type RCCT34 ... 39/XR (option /EF5) :

- Flame proof with Intrinsically safe connection to detector (ib)
- Additional Intrinsically safe outputs.
- Ex d ib [ia Ga] IIC T6...T3 Gb or
Ex d e ib [ia Ga] IIC T6...T3 Gb
- Ex d ib [ia IIC Ga] IIB T6...T3 Gb or
Ex d e ib [ia IIC Ga] IIB T6...T3 Gb with option /HP
- Ex ib tb [ia Da] IIIC T150°C Db
- Max. surface temperature : 150°C (302°F)
- Degree of protection : IP66/67
- Power supply : 90 to 250 V AC, 50/60 Hz or
20.5 to 28.8 V DC
- Power consumption : max. 25 VA / 10 W
- Ambient humidity : 0 to 95% RH
- Ambient temperature range: -40°C to +55°C (-40°F to 131°F)
- Process temperature range : -50°C to 150°C (-58°F to 302°F)

Electrical data remote detector RCCS30LR ... 33 :

- Driving circuit : terminals D+ and D
- Ex ib IIC : $U_i = 16 \text{ V}$; $I_i = 53 \text{ mA}$; $P_i = 0.212 \text{ W}$
 $L_i = 4.2 \text{ mH}$; $C_i = \text{negligible small}$
- Ex ib IIB : $U_i = 16 \text{ V}$; $I_i = 153 \text{ mA}$; $P_i = 0.612 \text{ W}$
 $L_i = 4.2 \text{ mH}$; $C_i = \text{negligible small}$
- Sensor circuits: terminals S1+ and S1- or S2+ and S2-
- Ex ib IIC : $U_i = 16 \text{ V}$; $I_i = 80 \text{ mA}$; $P_i = 0.32 \text{ W}$
 $L_i = 4.2 \text{ mH}$; $C_i = \text{negligible small}$
- Temperature sensor circuit : terminals TP1, TP2, TP3
- Ex ib IIC : $U_i = 16 \text{ V}$; $I_i = 50 \text{ mA}$; $P_i = 0.2 \text{ W}$
 $L_i = \text{negligible small}$; $C_i = \text{negligible small}$

Electrical data remote detector RCCS34 ... 39/XR :

- Driving circuit : terminals D+ and D
- Ex ib IIC : $U_i = 16 \text{ V}$; $I_i = 53 \text{ mA}$; $P_i = 0.212 \text{ W}$
 $L_i = 3.2 \text{ mH}$; $C_i = \text{negligible small}$
- Ex ib IIB : $U_i = 16 \text{ V}$; $I_i = 153 \text{ mA}$; $P_i = 0.612 \text{ W}$
 $L_i = 3.2 \text{ mH}$; $C_i = \text{negligible small}$
- Sensor circuits: terminals S1+ and S1- or S2+ and S2-
- Ex ib IIC : $U_i = 16 \text{ V}$; $I_i = 80 \text{ mA}$; $P_i = 0.32 \text{ W}$
 $L_i = 2.1 \text{ mH}$; $C_i = \text{negligible small}$
- Temperature sensor circuit : terminals TP1, TP2, TP3
- Ex ib IIC : $U_i = 16 \text{ V}$; $I_i = 50 \text{ mA}$; $P_i = 0.2 \text{ W}$
 $L_i = \text{negligible small}$; $C_i = \text{negligible small}$

Electrical data remote converter RCCF31, RCCR31 and converter of integral type RCCT3 ... :

- Driving circuit : terminals D+ / D-
- Ex [ib] IIC : $U_o = 14.5 \text{ V}$; $I_o = 47 \text{ mA}$; $P_o = 0.171 \text{ W}$
 $L_o = 15 \text{ mH}$; $C_o = 0.65 \mu\text{F}$
- Ex [ib] IIB : $U_o = 11.7 \text{ V}$; $I_o = 124 \text{ mA}$; $P_o = 0.363 \text{ W}$
 $L_o = 8 \text{ mH}$; $C_o = 10.3 \mu\text{F}$
- Sensor circuits: terminals S1+/ S1- or S2+ / S2-
- Ex [ib] IIB/IIC : $U_o = 14.5 \text{ V}$; $I_o = 47 \text{ mA}$; $P_o = 0.171 \text{ W}$
- Ex [ib] IIC : $L_o = 15 \text{ mH}$; $C_o = 0.65 \mu\text{F}$
- Ex [ib] IIB : $L_o = 60 \text{ mH}$; $C_o = 4.07 \mu\text{F}$
- Temperature sensor circuit : terminals TP1, TP2, TP3
- Ex [ib] IIB/IIC : $U_o = 13.3 \text{ V}$; $I_o = 40 \text{ mA}$; $P_o = 0.133 \text{ W}$
- Ex [ib] IIC : $L_o = 20 \text{ mH}$; $C_o = 0.91 \mu\text{F}$
- Ex [ib] IIB : $L_o = 80 \text{ mH}$; $C_o = 5.6 \mu\text{F}$
- Current output (only option /EF5) :
- Ex ia IIC : $U_i = 30 \text{ V}$; $I_i = 300 \text{ mA}$; $P_i = 1.25 \text{ W}$
 $L_i = 4 \mu\text{H}$; $C_i = 5.5 \text{ nF}$
- Pulse output (only option /EF5) :
- Ex ia IIC : $U_o = 30 \text{ V}$; $I_o = 300 \text{ mA}$; $P_o = 1.25 \text{ W}$
 $L_o = 4 \mu\text{H}$; $C_o = 13.1 \text{ nF}$

For temperature classification see table 7.

Table 7 : Temperature classification for ATEX, FM, IECEx, INMETRO, NEPSI and KOSHA certified flowmeter

Temp. class	RCCS30LR to RCCS33 without insulation		RCCS30LR to RCCS33 with factory insulation	
	Max. ambient temperature	Max. process temperature	Max. ambient temperature	Max. process temperature
T6	50°C / 122°F	60°C / 140°F	60°C / 140°F	60°C / 140°F
T5	50°C / 122°F	80°C / 176°F	80°C / 176°F	90°C / 194°F
T4	80°C / 176°F 50°C / 122°F	100°C / 212°F 120°C / 248°F	80°C / 176°F	130°C / 266°F
T3	80°C / 176°F	180°C / 356°F	80°C / 176°F	180°C / 356°F
T2	80°C / 176°F	260°C / 500°F	80°C / 176°F	260°C / 500°F
T1	80°C / 176°F	260°C / 500°F	80°C / 176°F	260°C / 500°F

Temp. class	RCCS34 to RCCS39/XR without insulation		RCCS34 to RCCS39/XR with factory insulation		RCCT34 to RCCT39/XR	
	Max. ambient temperature	Max. process temperature	Max. ambient temperature	Max. process temperature	Max. ambient temperature	Max. process temperature
T6	40°C / 104°F	40°C / 104°F	65°C / 149°F	65°C / 149°F	55°C / 122°F	65°C / 149°F
T5	55°C / 131°F	55°C / 131°F	75°C / 167°F	75°C / 167°F	55°C / 122°F	80°C / 176°F
T4	80°C / 176°F 40°C / 104°F	100°C / 212°F 120°C / 248°F	70°C / 158°F	115°C / 239°F	55°C / 122°F	115°C / 239°F
T3	80°C / 176°F 40°C / 104°F	160°C / 320°F 180°C / 356°F	70°C / 158°F	180°C / 356°F	55°C / 122°F	150°C / 302°F
T2	80°C / 176°F	220°C / 428°F	65°C / 149°F	275°C / 527°F	55°C / 122°F	150°C / 302°F
T1	80°C / 176°F	220°C / 428°F	45°C / 113°F	350°C / 662°F	55°C / 122°F	150°C / 302°F

For customer insulation of RCCS30LR to 39/XR the following must be regarded :
The table "with factory insulation" is calculated with 80 mm insulation and k-factor = 0.4 W/m²K.
If your insulation data are worse than these use table "without insulation" !

INMETRO APPROVAL (For Brazil)

Certificate TÜV 11.0419 X
RCCS3□ with option /US1 same as IECEx /ES1
RCCT3□ with options /UF1 or /UF5 same as IECEx /EF1 or /EF5
RCCF31 with options /UF1 or /UF5 same as IECEx /EF1 or /EF5
RCCR31 with option /US1 same as IECEx /ES1
Same parameters and specifications as IECEx approval.

NEPSI APPROVAL (For China)

Certificate GYJ12.1381X
RCCS3□ with option /NS1, RCCT3□ with options /NF1 + /NF5,
RCCF31 with options /NF1 + /NF5, RCCR31 with option /NS1
Same parameters and specifications as IECEx approval
except NEPSI has no dust proof certification.

KOSHA APPROVAL (For Korea)

Same parameters and specifications as IECEx approval.
Meter with IECEx option must be ordered.

TS APPROVAL (For Taiwan)

Certificate ML0412007041H6
Same parameters and specifications as IECEx approval.
Meter with IECEx option must be ordered.
For export to Taiwan please contact your Yokogawa
representative regarding Taiwan Safety Mark.

PESO APPROVAL (For India)

Same parameters and specifications as ATEX approval.
Meter with ATEX option must be ordered.

EAC APPROVAL (For Russia, Kazakhstan, Belorussia)

Certificate RU C-DE.ГБ08.В.00208
RCCS3□ with option /GS1
RCCT3□ with options /GF1 or /GF5
RCCF31 with options /GF1 or /GF5
RCCR31 with option /GS1
Same parameters and specifications as IECEx approval.

METROLOGICAL REGULATION IN CIS AND EAC COUNTRIES

Russia, Kazakhstan, Uzbekistan, Belorussia and Turkmenistan
are members of CIS.
Rotamass has "Pattern Approval Certificate of Measuring
Instruments" and is registered as a measuring instrument in
Russia, Kazakhstan, Uzbekistan, Belorussia and Turkmenistan.
Option /QR2 is for Kazakhstan.
Option /QR3 is for Uzbekistan.
For the Ukraine the test certificate of Rota Yokogawa is sufficient.
Therefore no special option exists.
Russia, Kazakhstan and Belorussia are covered by EAC.
For export to CIS and EAC countries please contact your
Yokogawa representative.

■ PLANNING AND INSTALLATION HINTS

Design Limits

It is the responsibility of the user to use the instrument within the given design limits. Erosion and corrosion influence the accuracy and may restrict the temperature / pressure limits. Therefore corrosion and erosion should be avoided.

Installation

The flowmeter can be installed vertically, horizontally or in any other position, as long as the measuring tubes are completely filled with the measured liquid during measurement.

Redundant Installation

If two flowmeters of the same size are installed in series mutual interference called cross talk may take place. Cross talk occurs due to the fact that both meters have the same resonance frequency. If serial installation is planned please contact your Yokogawa representative who can ensure that a frequency adjustment is made to one of the meters at the factory.

Sizing

The measuring range and accuracy are virtually independent of fluid conditions and size of the connecting pipe. Select a suitable nominal size from pressure loss calculation. Check whether the measuring range and accuracy at minimal flow fit the application. The calculations of the pressure loss are based on newtonian fluids. For correct calculation please contact your local Yokogawa representative.

Sanitary Applications

For sanitary applications select process connection S2, S4 or S8. The wetted surface will be $Ra \leq 1.6 \mu\text{m}$. However, if option /SF□ is selected the surface roughness will be $Ra < 0.8 \mu\text{m}$ and with /SF2 a certificate with a 3-point roughness measurement certificate is delivered. The EHEDG certificate shows that ROTAMASS conforms to the EHEDG criteria regarding the capability to be cleaned by a CIP process. The evaluation does not include the process connections and seals.

Cavitation

To avoid cavitation keep the back pressure of the fluid sufficiently above the vapor pressure of the fluid. For low viscous fluids following condition should be fulfilled at the given temperature:

$$p_{\text{back}} > p_{\text{vapor}} + 0.7 \cdot \Delta p$$

With Δp = pressure loss

Long Term Stability

To get stable deflection of the tubes by the Coriolis forces the stiffness and therefore the wall thickness has to be kept constant during measuring. With corrosion or erosion the meter factor is drifting with time and recalibration is necessary. Select the suitable resistant tube material for the process!

Recalibration Service

Yokogawa offers full recalibration service, if necessary with a certificate traceable to German national standards. Please contact your Yokogawa affiliate or directly Rota Yokogawa, Germany.

Heat Tracing and Insulation

Basically the detector can be insulated by the customer. To be sure not to overheat the connection box choose one of /T□ options (insulation or heat tracing from Yokogawa) or /S2. For process temperatures between 150°C (302°F) and 230°C (446°F) (RCCS34 - 39/XR) or 260°C (500°F) (RCCS30LR - 33) choose /MT option and remote installation. If ROTAMASS detector with /MT or /HT is not insulated, the accuracy specification can not be guaranteed. The converter should not be exceeded more than 50°C (122°F). Therefore never insulate the converter and keep the neck free from insulation too. Yokogawa will not take any liability regarding customer insulation.

Relations between Options /MT, /HT, /S2 and /T□ (/T1, /T2, /T3)

The meters with high temperature options (/MT, /HT) can be insulated either by the customer by using option /S2 (prolonged neck) or by the factory through options /T□. The /T□ options already include the option /S2 so that the /S2 option can not be selected in case of the /T□ options. If the meter is not properly insulated by the customer, the accuracy specification can not be guaranteed.

Installation above 100°C (212°F) Process Temperature

To provide enough cooling the instrument should be installed vertically or horizontally with the converter down. This is recommended for size RCC□36 and larger without /T□ option.

Installation below 0°C (32°F) Process Temperature

The detector can be insulated to prevent ice capping either by the customer or by the manufacturer. Ask your Yokogawa representative for special insulation. If the customer wants to insulate by themselves a closed cell foam as insulation material is recommended to avoid water siphon. In this case option /S2 should be selected. For temperatures below -70°C (-94°F) option /LT is recommended (on request).

Zero Adjustment Function

Zero point can be adjusted either by setting the switches on display or with the HART® communication or with status input when the fluid flow is stopped and the detector filled. To ensure no flow conditions isolation valves should be installed. To achieve the specified accuracy a zero should be performed at process conditions (temperature, pressure).

Pressure / Temperature Dependencies of Process Connections

See also process pressure limits in chapter "Normal operation conditions."

Rupture Disk

The rupture disk is used as annunciation method in the case of tube rupture (Dual Seal) preferable for high pressure gas service. Practically a tube rupture of ROTAMASS is not known to the manufacturer. For large sizes it cannot be expected that the full line pressure can be released via the rupture disk. If this is requested please contact Yokogawa for a special execution.

Explosion Proof Concept

The detector is intrinsically safe Ex ib, the converter RCCT and RCCF31 are flame (explosion) proof. The converter RCCR31 is an intrinsically safe associated apparatus. The driving power from converter to detector is limited and protected by an intrinsically safe barrier, which is part of the converter. The barrier is protecting the detector either for gas group IIC or IIB (option /HP). Option /KF5 delivers two passive intrinsically safe current and one pulse output, however the converter is flame (explosion) proof.

Option /HP

With option /HP the detector driving power is higher which is benefit to 2 phase flow. This is also true for non hazardous applications.

Gas Measurement

For gas applications please choose the option /GA. Density reading below 0.3 kg/l is not possible. Volume flow is calculated by using the fix density value stored in „Reference density“. Based on the selection of the gas density, the following volume flow rates can be calculated; standard, reference, normal. Besides, the corresponding volume flow rate units can be selected. Some functions are unavailable for gas measurement, including concentration measurement, empty pipe, slug or corrosion detection.

Good and stress free installation is mandatory for a stable Zero. Attention to resonance phenomenons has to be taken if gas compressors are used in the pipe. Flow noise has to be avoided.

Batch Process

Density Measurement

There are 3 levels of density measurement. The standard adjustment and /K4 delivers an accuracy up to 0.001 g/cm³, if the fluid density is around 1 kg/l. However, at elevated temperatures the density error may increase. For option /K4 the instrument is preheated ensuring long term stability. However, if high density stability is needed at high temperatures option /HT is recommended. Option /K6 includes preheating, a full calibration at 3 different densities, increased temperature measurement specification and individual adjustment of the fluid temperature dependency. Multi-phase flow can generate higher deviations. The higher the density differences of the single components are the more likely it is that a negative density error is generated. Aeration has to be avoided fully to receive good density measurement.

For more information please see TI 01R04B04-05E "Density Measurement with ROTAMASS"

Note: Density specification under calibration condition only with flow direction "forward" according the arrow on the meter.

Table 8: Overview density-/volume- flow measurement:

Option	Accuracy	Certificate	Description	Typical Application
Standard	± 0.0015 g/cm ³ to ± 0.02 g/cm ³	Standard (mass flow) factory calibration certificate	- Standard adjustment with water and air - Density constants given in mass flow certificate	- Process medium and environment are approximately at room temperature, the density range is 0.9 kg/l to 1.1 kg/l
Option /K4	± 0.001 g/cm ³	Standard (mass flow) factory calibration certificate	- Thermal treatment of the sensor and special hardware design - Standard adjustment with water and air - Density constants given in mass flow certificate	- Improved volume flow accuracy - Process medium up to 150°C, for higher temperature select option /MT or /HT - Density range is 0.9 kg/l to 1.1 kg/l
Option /K6	± 0.0005 g/cm ³	Separate factory density calibration certificate	- Thermal treatment of the sensor and special hardware design - Density calibration with 3 different liquids - Individual adjustment of the fluid temperature dependency	- Density and concentration measurement in addition to the mass flow: - Process medium up to 150°C, for higher temperature select option /HT - Density range 0.3 kg/l to 2.5 kg/l - Best volume flow accuracy

The specified mass flow accuracy applies if the batch process is >1 minute. For shorter batch time (Δt in s) the accuracy decreases with the square root of $60/\Delta t$.

For short batches the opening and closing times of the valves have to be longer than 2 seconds.

Concentration Measurement for Liquids

The Standard Concentration Measurement (option /CST) is suitable for concentration measurement of emulsions or suspensions, where the density of the solid is assumed to be fix. It can also be used for (mainly low concentration) solutions if the two fluids are not strongly interacting. The density change of the liquid components due to temperature can normally be described with a linear or quadratic function with very high accuracy within the desired measurement range. The coefficients of these function (linear and quadratic thermal expansion coefficients) must be either known or have to be determined prior to using this function.

For interacting liquids the Advanced Concentration Measurement options should be used, these options can be ordered using the appropriate /C□□ concentration measurement option. For more information please see TI 01R04B04-04E-E "Concentration Measurement with ROTAMASS"

Table 9 : Pressure rating

Type of process connection		Process Temperature							
		RT ³⁾	50°C	100°C	150°C	200°C	250°C	300°C	350°C
A1 ²⁾	Flange acc. ASME B16.5 Class 150	19 bar	18.4 bar	16.2 bar	14.8 bar	13.7 bar	12.1 bar	10.2 bar	8.4 bar
A2 ²⁾	Flange acc. ASME B16.5 Class 300	49.6 bar	48.1 bar	42.2 bar	38.5 bar	35.7 bar	33.4 bar	31.6 bar	30.3 bar
A3 ²⁾	Flange acc. ASME B16.5 Class 600 excl. RCC ³⁾ 39/XR	99.3 bar	96.2 bar	84.4 bar	77 bar	71.3 bar	66.8 bar	63.2 bar	60.7 bar
A3 ²⁾	Flange acc. ASME B16.5 Class 600 for RCC ³⁾ 39/XR	95 bar	89 bar	80 bar	73 bar	67 bar	62 bar	59 bar	58 bar
A4 ²⁾	Flange acc. ASME B16.5 Class 900 without /DS	148.9 bar	144.3 bar	126.6 bar	115.5 bar	107 bar	100.1 bar	94.9 bar	91 bar
A4 ²⁾⁴⁾	Flange acc. ASME B16.5 Class 900 with /DS	130 bar	126 bar	110.5 bar	100.8 bar	93.4 bar	87.4 bar	82.9 bar	79.4 bar
A5 ²⁾	Flange acc. ASME B16.5 Class 1500 excl. RCC ³⁾ 36	248.2 bar	240.6 bar	211 bar	192.5 bar	178.3 bar	166.9 bar	158.1 bar	151.6 bar
A5 ²⁾	Flange acc. ASME B16.5 Class 1500 for RCC ³⁾ 36	210 bar	203 bar	176 bar	160 bar	148 bar	140 bar	133 bar	128 bar
D2 ¹⁾	Flange acc. EN 1092-1 PN 16	16 bar	15.7 bar	15.1 bar	13.7 bar	12.7 bar	11.9 bar	11.0 bar	10.5 bar
D4 ¹⁾	Flange acc. EN 1092-1 PN 40	40 bar	39.2 bar	37.9 bar	34.4 bar	31.8 bar	29.9 bar	27.6 bar	26.4 bar
D5 ¹⁾	Flange acc. EN 1092-1 PN 63	63 bar	61.8 bar	59.7 bar	54.3 bar	50.1 bar	47.1 bar	43.5 bar	41.7 bar
D6 ¹⁾	Flange acc. EN 1092-1 PN 100	100 bar	98 bar	94.7 bar	86.1 bar	79.5 bar	74.7 bar	69.0 bar	66.1 bar
D7 ¹⁾	Flange acc. EN 1092-1 PN 160	160 bar	156.9 bar	151.6 bar	137.9 bar	127.2 bar	119.6 bar	110.4 bar	105.9 bar
G9 ¹⁾⁴⁾	Internal thread RCCS30LR ... 33	285 bar	271 bar	247 bar	227 bar	208 bar	183 bar	-----	-----
T9 ¹⁾	Internal thread NPT RCCS30LR ... 33	285 bar	271 bar	247 bar	227 bar	208 bar	183 bar	-----	-----
G9 ¹⁾⁴⁾	Internal thread RCCS34	260 bar	251 bar	231 bar	208 bar	190 bar	178 bar	167 bar	160 bar
T9 ¹⁾⁴⁾	Internal thread NPT RCCS34	260 bar	251 bar	231 bar	208 bar	190 bar	178 bar	167 bar	160 bar
		Process Temperature							
		up to 120°C			220°C		300°C	350°C	
J1 ¹⁾	Flange acc. JIS B 2220 10K	14 bar			12 bar		10 bar	-----	
J2 ¹⁾	Flange acc. JIS B 2220 20K	34 bar			31 bar		29 bar	26 bar	
		Process Temperature							
		up to 140°C ¹⁾							
S2 ¹⁾	Pipe connection up to DN 40	40 bar							
	acc. DIN 11851 DN 50 to DN 100	25 bar							
	above DN 100	16 bar							
) under the restriction using suitable gasket materials							
		Process Temperature							
		up to 150°C ¹⁾							
S4 ¹⁾	Clamp connection up to DN 50	16 bar							
	acc. DIN 32676 above DN 50	10 bar							
S8 ¹⁾	Clamp acc. Mini-Clamp up to 1/2"	16 bar							
	Clamp acc. Tri-Clamp [®] up to 2" above 2"	16 bar 10 bar							
		") under the restriction using suitable gasket materials							

Type of process connection		Process Temperature							
		RT ³⁾	120°F	210°F	300°F	390°F	480°F	570°F	660°F
A1 ²⁾	Flange acc. ASME B16.5 Class 150	276 psi	267 psi	235 psi	215 psi	199 psi	175 psi	148 psi	122 psi
A2 ²⁾	Flange acc. ASME B16.5 Class 300	719 psi	698 psi	612 psi	558 psi	518 psi	484 psi	458 psi	439 psi
A3 ²⁾	Flange acc. ASME B16.5 Class 600 excl. RCC ³⁾ 39/XR	1440 psi	1395 psi	1224 psi	1117 psi	1034 psi	969 psi	917 psi	880 psi
A3 ²⁾	Flange acc. ASME B16.5 Class 600 for RCC ³⁾ 39/XR	1378 psi	1291 psi	1160 psi	1059 psi	972 psi	899 psi	856 psi	841 psi
A4 ²⁾	Flange acc. ASME B16.5 Class 900 without /DS	2160 psi	2093 psi	1836 psi	1675 psi	1552 psi	1452 psi	1376 psi	1320 psi
A4 ²⁾⁴⁾	Flange acc. ASME B16.5 Class 900 with/DS	1885 psi	1827 psi	1602 psi	1461 psi	1354 psi	1267 psi	1202 psi	1151 psi
A5 ²⁾	Flange acc. ASME B16.5 Class 1500 excl. RCC ³⁾ 36	3600 psi	3490 psi	3060 psi	2792 psi	2586 psi	2421 psi	2293 psi	2199 psi
A5 ²⁾	Flange acc. ASME B16.5 Class 1500 for RCC ³⁾ 36	3046 psi	2944 psi	2553 psi	2321 psi	2147 psi	2031 psi	1929 psi	1856 psi
D2 ¹⁾	Flange acc. EN 1092-1 PN 16	232 psi	227 psi	219 psi	198 psi	184 psi	172 psi	159 psi	152 psi
D4 ¹⁾	Flange acc. EN 1092-1 PN 40	580 psi	568 psi	549 psi	499 psi	458 psi	433 psi	400 psi	382 psi
D5 ¹⁾	Flange acc. EN 1092-1 PN 63	914 psi	896 psi	865 psi	787 psi	726 psi	683 psi	630 psi	604 psi
D6 ¹⁾	Flange acc. EN 1092-1 PN 100	1450 psi	1421 psi	1373 psi	1248 psi	1152 psi	1083 psi	1000 psi	958 psi
D7 ¹⁾	Flange acc. EN 1092-1 PN 160	2320 psi	2275 psi	2198 psi	1999 psi	1844 psi	1734 psi	1600 psi	1535 psi
G9 ¹⁾⁴⁾	Internal thread RCCS30LR ... 33	4133 psi	3930 psi	3582 psi	3292 psi	3016 psi	2653 psi	-----	-----
T9 ¹⁾	Internal thread NPT RCCS30LR ... 33	4133 psi	3930 psi	3582 psi	3292 psi	3016 psi	2653 psi	-----	-----
G9 ¹⁾⁴⁾	Internal thread RCCS34	3770 psi	3640 psi	3350 psi	3016 psi	2755 psi	2581 psi	2422 psi	2320 psi
T9 ¹⁾⁴⁾	Internal thread NPT RCCS34	3770 psi	3640 psi	3350 psi	3016 psi	2755 psi	2581 psi	2422 psi	2320 psi
		Process Temperature							
		up to 248°F			428°F		572°F	662°F	
J1 ¹⁾	Flange acc. JIS B 2220 10K	1203 psi			174 psi		145 psi	-----	
J2 ¹⁾	Flange acc. JIS B 2220 20K	493 psi			449 psi		420 psi	377 psi	
		Process Temperature							
		up to 284°F ¹⁾							
S2 ¹⁾	Pipe connection up to DN 40	580 psi							
	acc. DIN 11851 DN 50 to DN 100	362 psi							
	above DN 100	232 psi							
) under the restriction using suitable gasket materials							
		Process Temperature							
		up to 302°F ¹⁾							
S4 ¹⁾	Clamp connection up to DN 50	232 psi							
	acc. DIN 32676 above DN 50	145 psi							
S8 ¹⁾	Clamp acc. Mini-Clamp up to 1/2"	232 psi							
	Clamp acc. Tri-Clamp [®] up to 2" above 2"	232 psi 145 psi							
		") under the restriction using suitable gasket materials							

¹⁾ process connection material: 1.4404 / 1.4435 (equivalent to group 2.3 material AISI 316L acc. ASME B16.5)

²⁾ process connection material: 1.4401/1.4404 AISI 316/316L

³⁾ RT = Room Temperature; EN1092: -10°C to 50°C; ASME B16.5: -29°C to 38°C

⁴⁾ for option /DS max. pressure according A4. ASME class 900 13% derated

DIMENSIONS

Integral Type RCCT34, RCCT36, RCCT38, RCCT39

Without Display

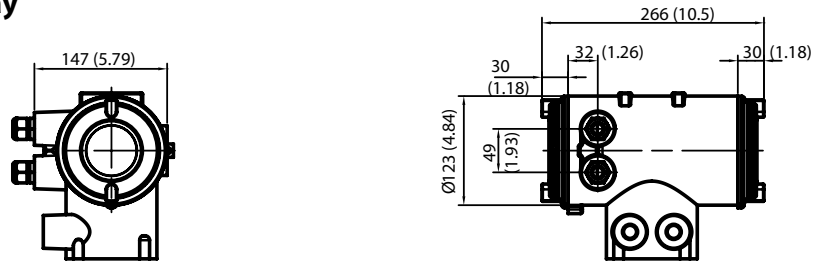

With Display

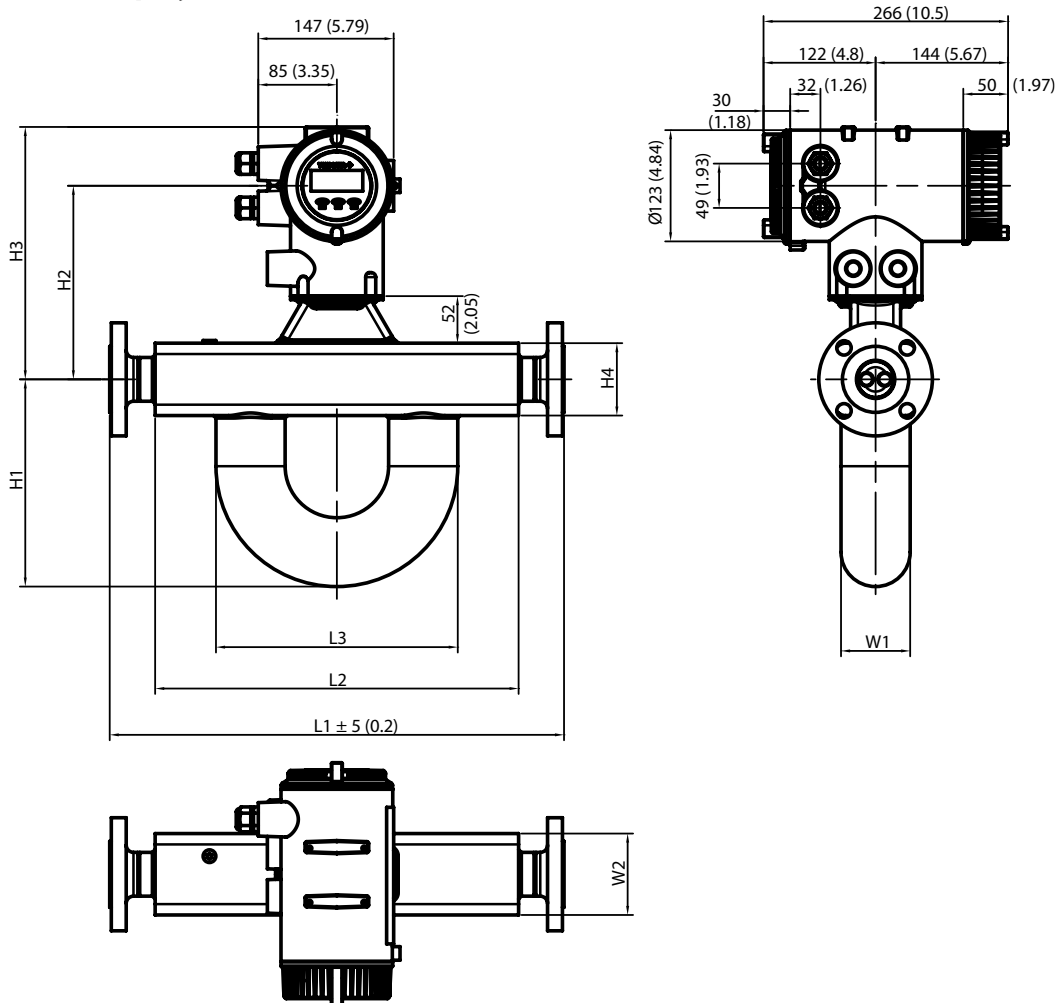

Note: The flange dimensions depend on size and pressure rating of the flange.

Model		L1	L2	L3	H1	H2	H3	H4	W1	W2	Weight
RCCT34	mm (inches)	see table 11	272 (10.7)	212 (8.35)	177 (6.97)	214 (8.43)	279 (11)	80 (3.15)	60 (2.36)	80 (3.15)	13-24 kg (29-53 lbs)
RCCT36	mm (inches)	see table 11	400 (15.7)	266 (10.5)	230 (9.06)	214 (8.43)	279 (11)	80 (3.15)	76 (2.99)	90 (3.54)	18-38 kg (40-84 lbs)
RCCT38	mm (inches)	see table 11	490 (19.3)	267 (10.5)	269 (10.6)	224 (8.82)	289 (11.4)	100 (3.94)	89 (3.5)	110 (4.33)	28-53 kg (62-117 lbs)
RCCT39	mm (inches)	see table 11	850 (33.5)	379 (14.9)	370 (14.6)	242 (9.54)	307(12.1)	135 (5.31)	129 (5.08)	160 (6.3)	63-106 kg (139-233 lbs)

Dimensions in mm (inches)..Weights with smallest and biggest flanges.

Integral Type RCCT39/IR-□□□□□□□□/V2

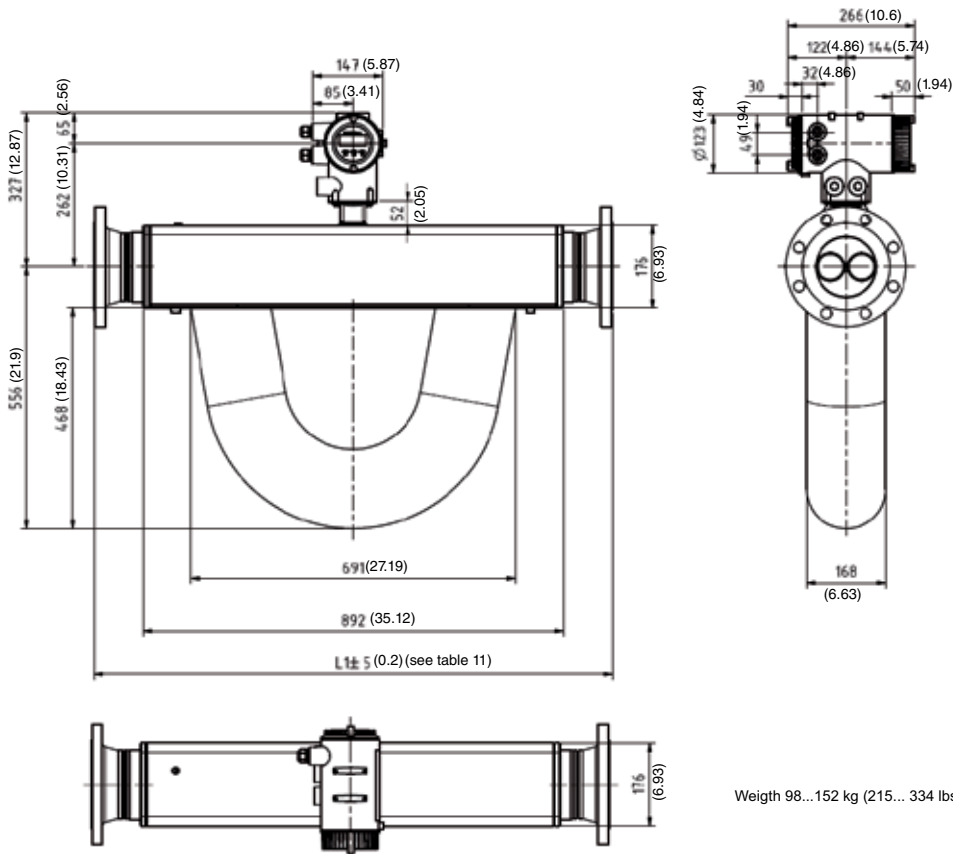

Dimensions in mm (inches). Weights with smallest and biggest flanges

Integral Type RCCT39/XR

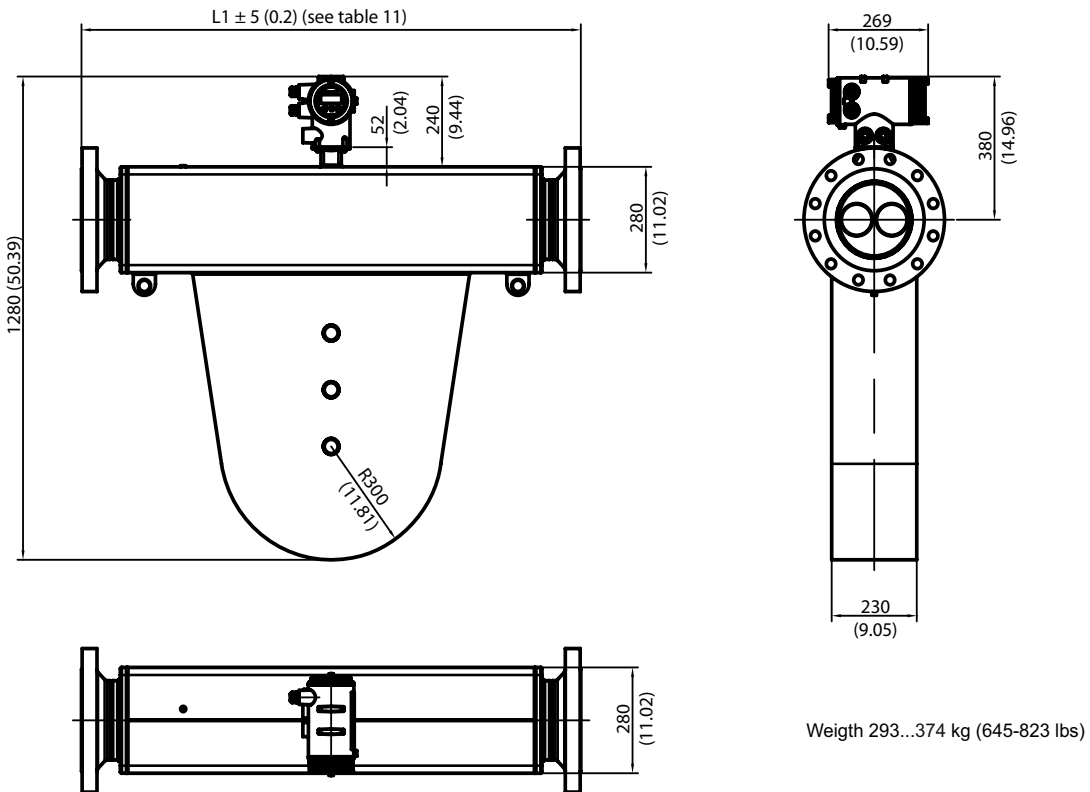

Dimensions in mm (inches). Weights with smallest and biggest flanges

Remote field-mount Converter RCCF31

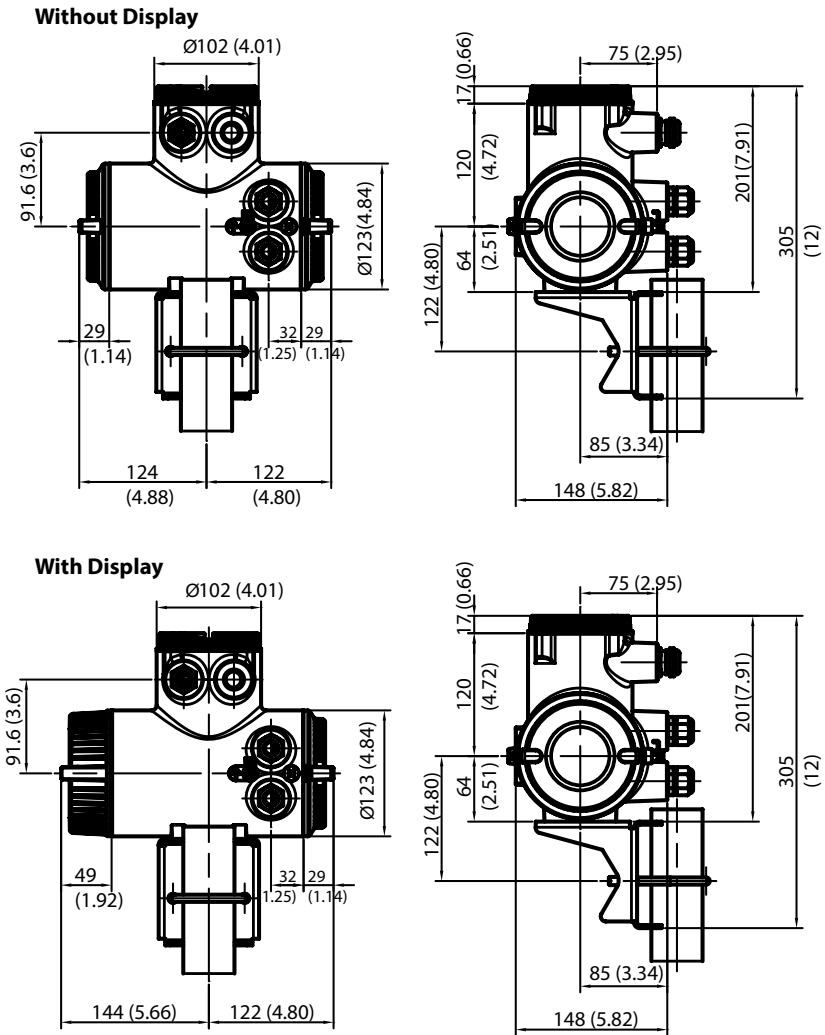

Weight with bracket: 5.5 kg (12.1 lbs) (depends on type)

Dimensions in mm (inches)

Remote rack-mount Converter RCCR31

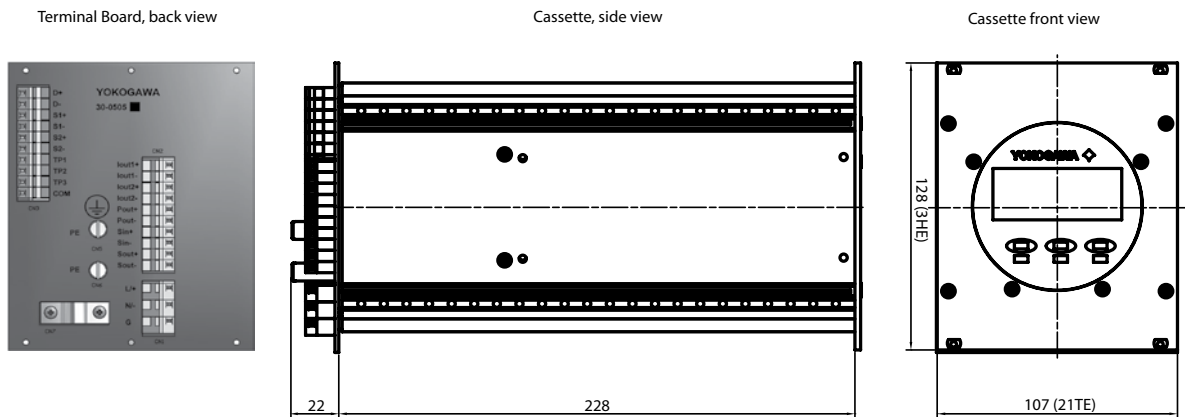

Dimensions in mm
 19-inch rack, acc. IEC / DIN EN 60297-3-101
 Weight: 1.5 kg

Dimensions in mm

Remote Detector RCCS30LR, RCCS30, RCCS31, RCCS32, RCCS33

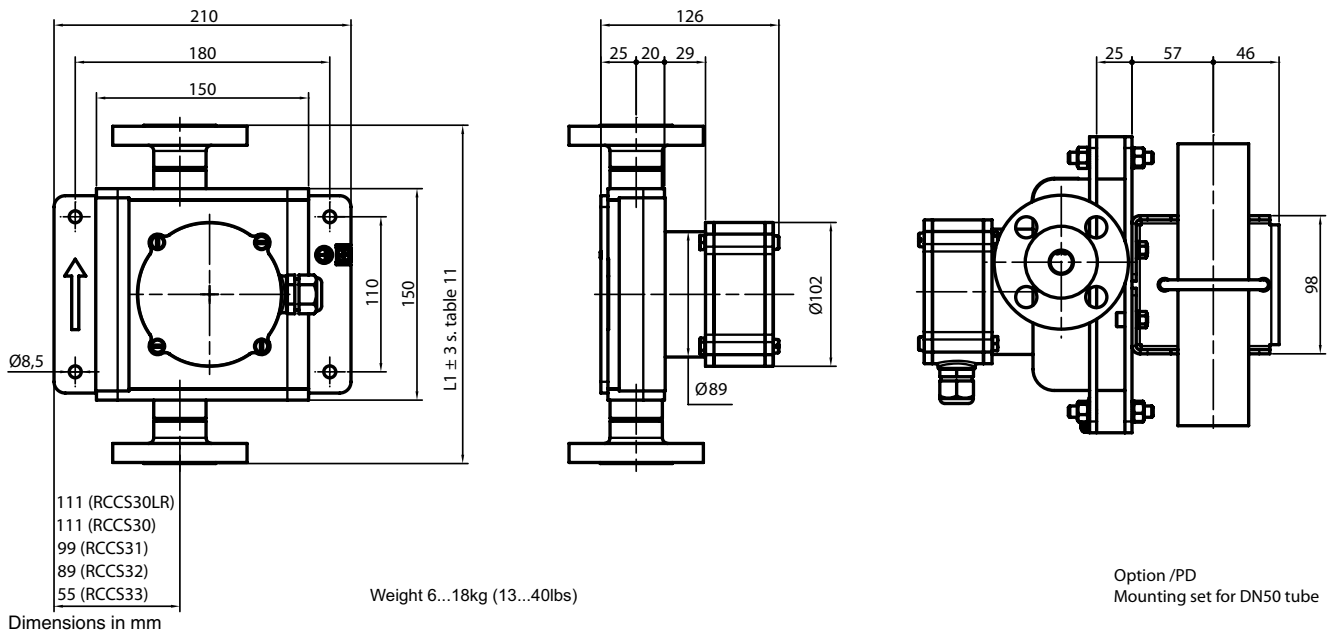

Remote Detector RCCS34, RCCS36, RCCS38, RCCS39

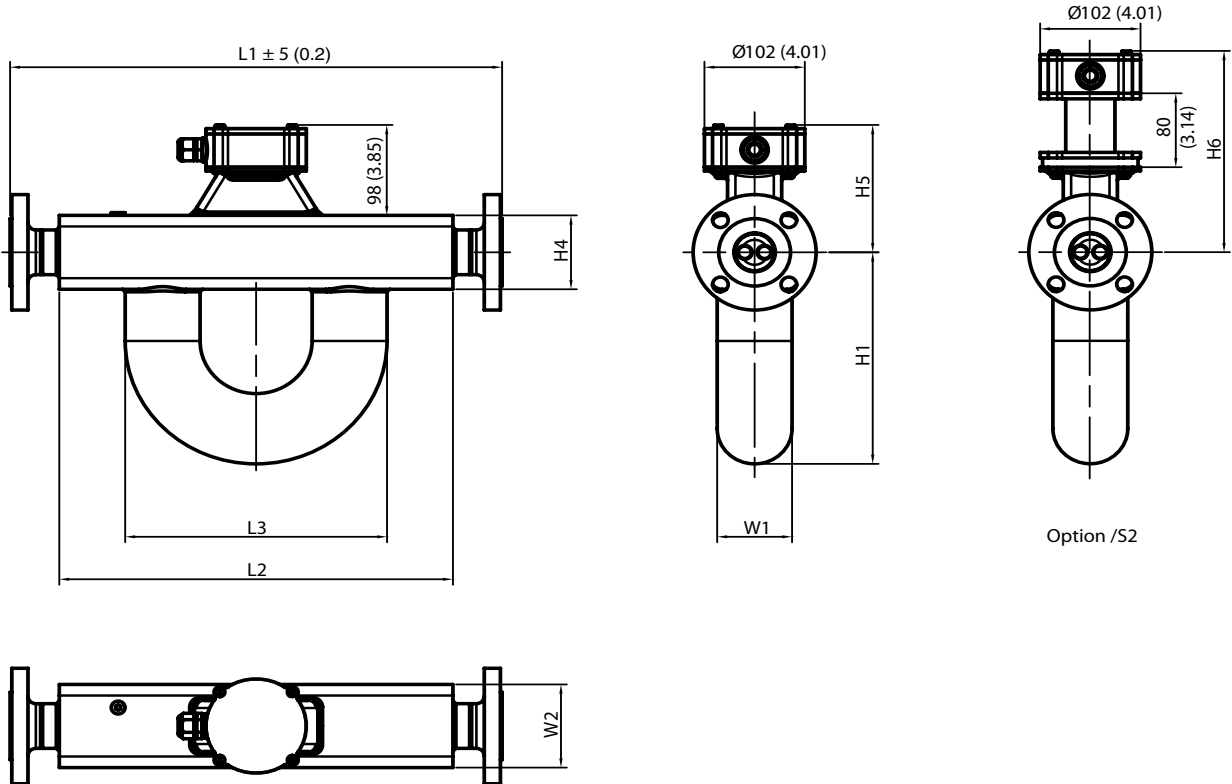

Note: The flange dimensions depend on size and pressure rating of the flange.

Model		L1	L2	L3	H1	W1	W2	H4	H5	H6	Weight
RCCS34	mm (inches)	see table 11	272 (10.7)	212 (8.35)	177 (6.97)	60 (2.36)	80 (3.15)	80 (3.15)	138 (5.43)	218 (8.58)	10-21 kg (22-46 lbs)
RCCS36	mm (inches)	see table 11	400 (15.7)	266 (10.5)	230 (9.06)	76 (2.99)	90 (3.54)	80 (3.15)	138 (5.43)	218 (8.58)	15-35 kg (33-77 lbs)
RCCS38	mm (inches)	see table 11	490 (19.3)	267 (10.5)	269 (10.6)	89 (3.5)	110 (4.33)	100 (3.94)	148 (5.82)	228 (8.97)	25-50 kg (55-110 lbs)
RCCS39	mm (inches)	see table 11	850 (33.5)	379 (14.9)	370 (14.6)	129 (5.08)	160 (6.3)	135 (5.31)	166 (6.53)	245 (9.65)	60-103 kg (132-227 lbs)

Dimensions in mm (inches)..Weights with smallest and biggest flanges.

Remote Detector RCCS39/IR-□□□□□□□□ /V2

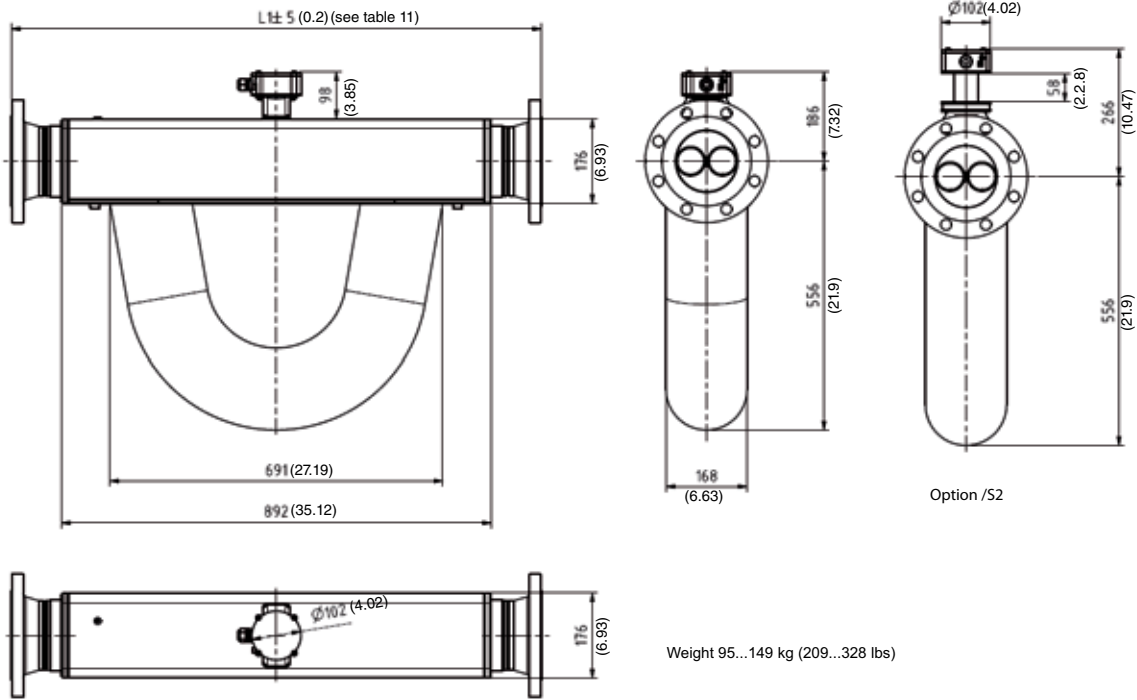

Weight 95...149 kg (209...328 lbs)

Dimensions in mm (inches). Weights with smallest and biggest flanges

Remote Detector RCCS39/XR

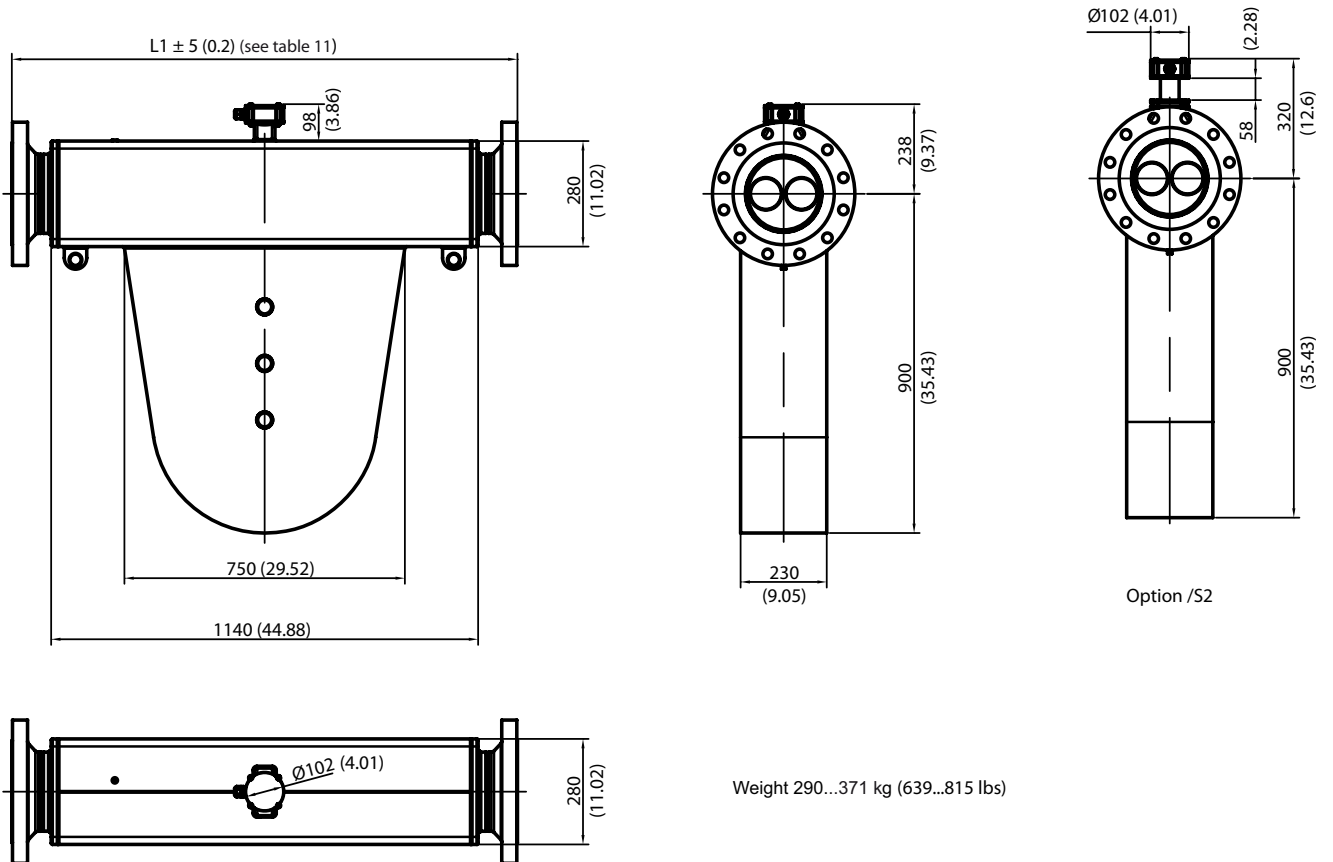

Weight 290...371 kg (639...815 lbs)

Dimensions in mm (inches). Weights with smallest and biggest flanges

Remote Detector RCCS39/XR with option /HT

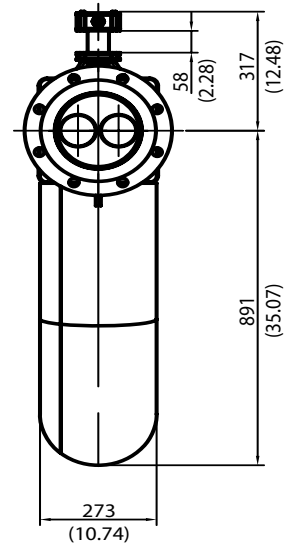
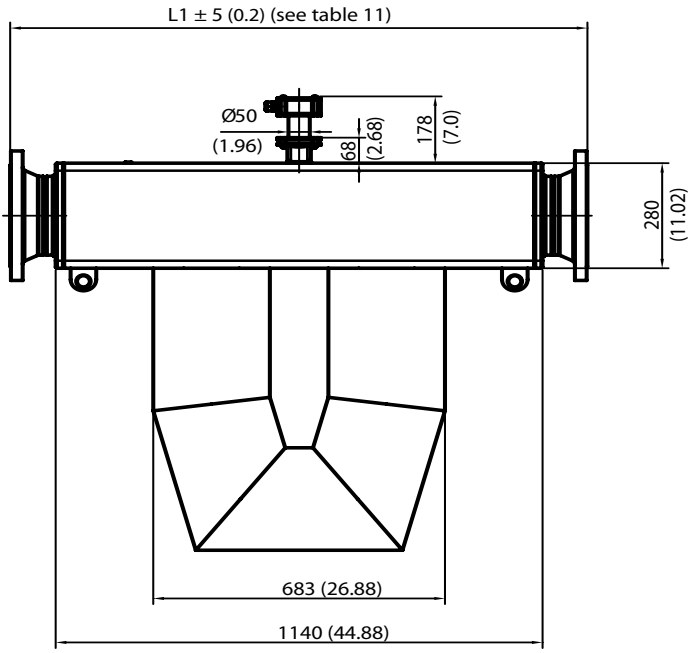

Option /S2

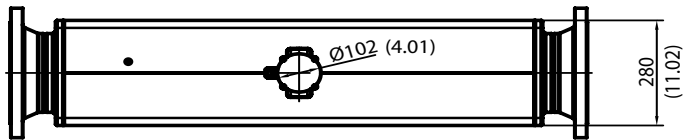

Dimensions in mm (inches). Weights with smallest and biggest flanges

Weight 290...370 kg
(639...815 lbs)

**Remote Detector RCCS34, RCCS36, RCCS38, RCCS39, RCCS39/IR-□□□□□□□□ /V2 with option /T□
(Insulation / Heating)**

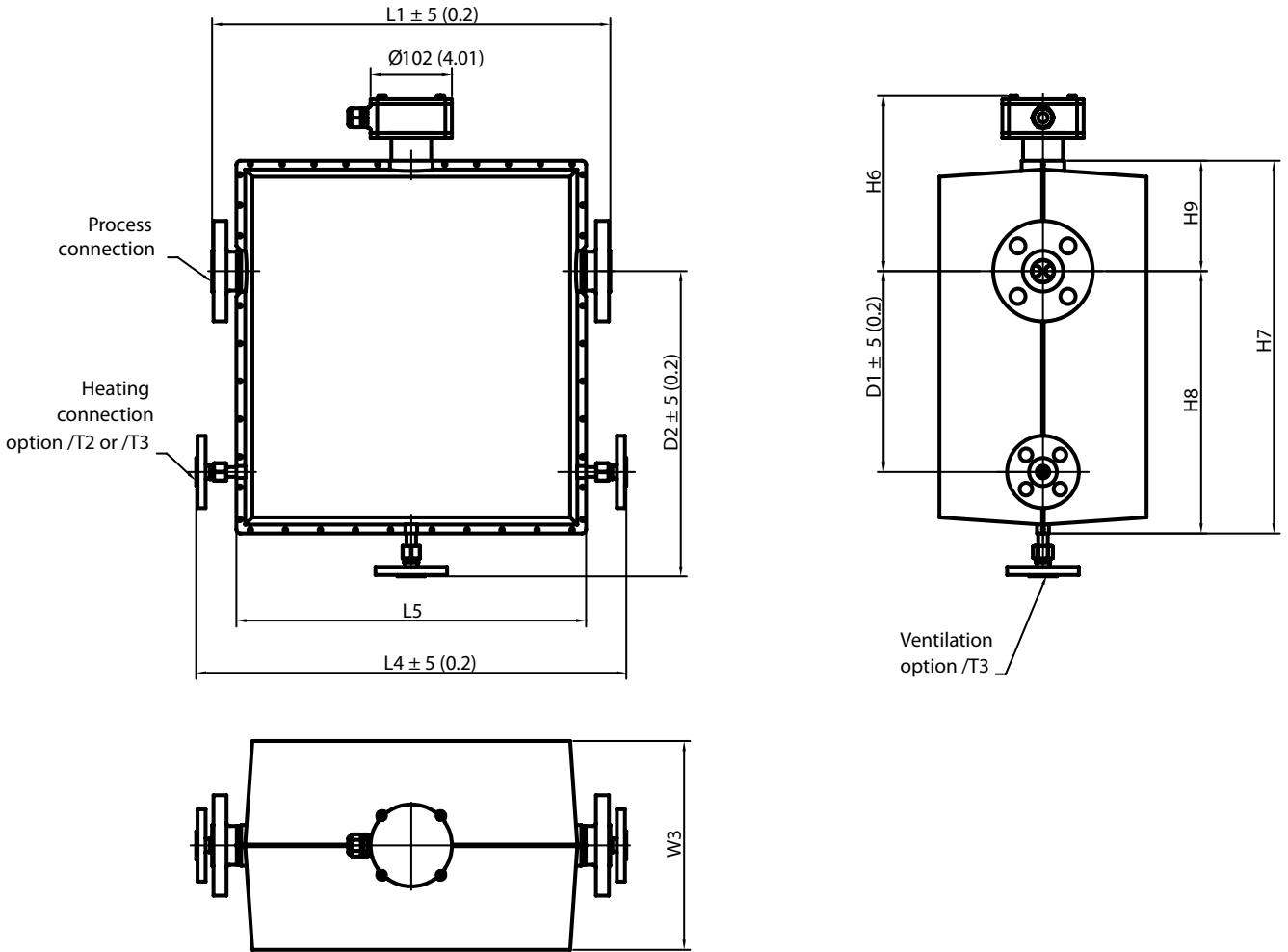

Note: The flange dimensions depend on size and pressure rating of the flange.

Model		L1	L4	L5	D1	D2	H6	H7	H8	H9	W3	Weight
RCCS34	mm (inches)	see table 11	420 (16.53)	310 (12.20)	200 (7.87)	330 (12.99)	218 (8.58)	411 (16.81)	273 (10.74)	138 (5.43)	240 (9.44)	19-30 kg (42-66 lbs)
RCCS36	mm (inches)	see table 11	540 (21.25)	439 (17.28)	250 (9.84)	380 (14.96)	218 (8.58)	464 (18.26)	326 (12.83)	138 (5.43)	260 (10.23)	28-48 kg (62-106 lbs)
RCCS38	mm (inches)	see table 11	640 (25.19)	530 (20.86)	250 (9.84)	430 (16.92)	228 (8.97)	524 (20.62)	376 (14.80)	148 (5.82)	260 (10.23)	40-65 kg (88-144 lbs)
RCCS39	mm (inches)	see table 11	1000 (39.37)	894 (35.19)	350 (13.77)	545 (21.45)	245 (9.65)	668 (26.29)	503 (19.80)	165 (6.49)	302 (11.88)	104-147 kg (230-325 lbs)
RCCS39/IR	mm (inches)	see table 11	1050 (41.34)	944 (37.16)	350 (13.77)	677 (26.65)	266 (10.47)	944 (37.16)	625 (24.61)	193 (7.6)	342 (13.46)	147-201 kg (325-444 lbs)

Dimensions in mm (inches)..Weights with smallest and biggest flanges including insulation cover and heat tracing.
Standard heating connection according table 10.

Remote Detector RCCS30LR, RCCS30, RCCS31, RCCS32, RCCS33 with option /T□ (Insulation / Heating)

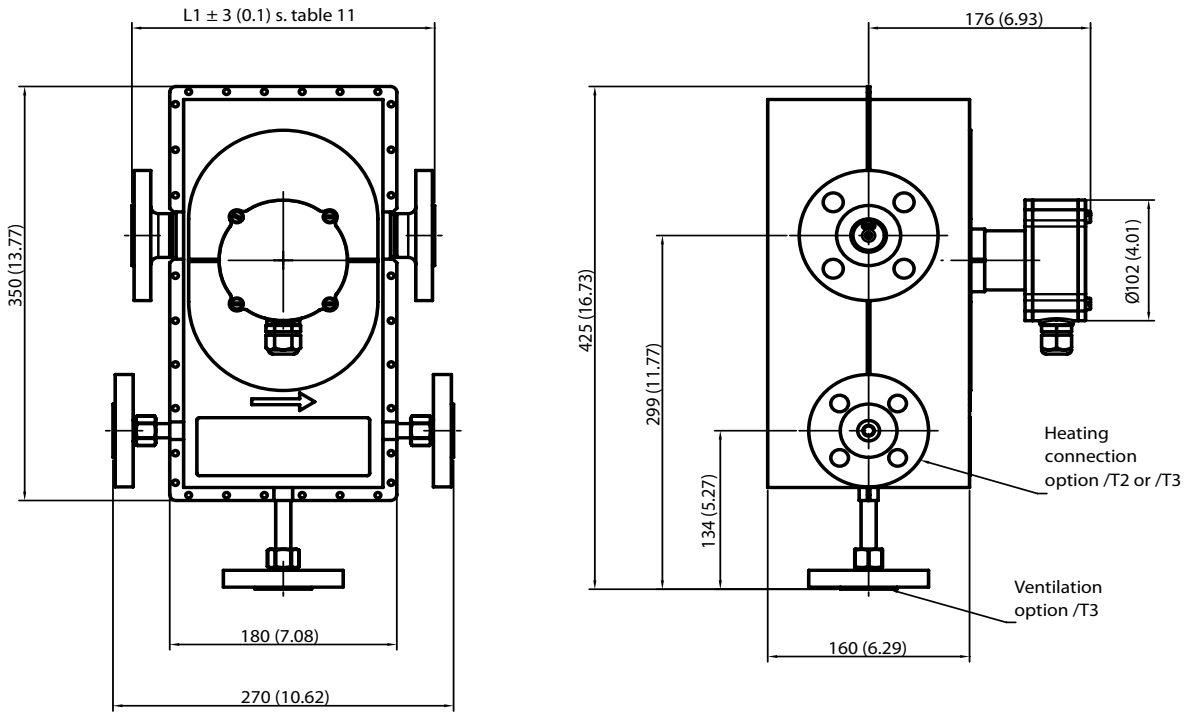

Dimensions in mm (inches)

Weight in kg (lbs) without flange			Weight in kg (lbs) with flange (01A1)		
/T1	/T2	/T3	/T1	/T2	/T3
8.7 (19.2)	11.5 (25.3)	12.5 (27.5)	9.5 (21)	12.3 (27.1)	13.3 (29.3)

Table 10: Heat tracing connection types depending on process connection type

Process connection	Standard heating connection *)
A□	ASME 1/2" - 150
D□	EN DN 15 PN 40
J□	JIS 10K DN15
S2 ; S4	EN DN 15 PN 40
S8	ASME 1/2" - 150
G9	EN DN 15 PN 40
T9	ASME 1/2" - 150

*) others on request

Adapter 1/2" NPT - G1/2 (option /AD2)

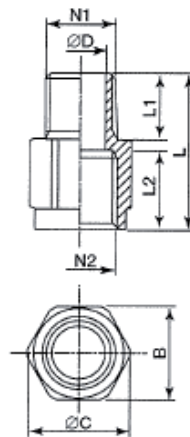

N1	N2	ØD [mm (in.)]	B [mm (in.)]	ØC [mm (in.)]	L1 [mm (in.)]	L2 [mm (in.)]	L [mm (in.)]	Weight [kg (lbs)]
1/2" NPT	G1/2"	15 (0.59)	27 (1.06)	30 (1.18)	19 (0.74)	23 (0.90)	45 (1.77)	0.07 (0.003)

MODEL, SUFFIX AND OPTION CODES

Integral Type RCCT3□, Model and Suffix Code

Model	Suffix Code	Description	Restrictions
RCCT34 RCCT36 RCCT38 RCCT39 RCCT39/IR RCCT39/XR		Nominal Value : 3 t/h = 50 kg/min (110,2 lbs/min) Nominal Value : 10 t/h = 170 kg/min (374.78 lbs/min) Nominal Value : 32 t/h = 533 kg/min (1175 lbs/min) Nominal Value : 100 t/h = 1670 kg/min (3681.72 lbs/min) Nominal Value : 250 t/h = 4170 kg/min (9193,27 lbs/min) Nominal Value : 500 t/h = 8340 kg/min (18386.55 lbs/min)	only with /V2 only with /HP
Power supply	-A -D	90 - 264 V AC 24 V DC	
Indicator direction	H1 H2 V0 N0	Detector installation horizontal, tubes down, recom. for liquid service Detector installation horizontal, tubes up, recommended for gas service /GA Detector installation vertical Without indicator	
Cable conduit connection	M A	M20 x 1.5, female thread with cable glands ANSI ½" NPT, female thread without cable glands	not with /FF1, /FF5
Process connection size ¹⁾	23 01 02 04 05 06 08 10 12 15 20	¾" DN 15, ½" DN 25, 1" DN 40, 1½" DN 50, 2" DN 65, 2½" DN 80, 3" DN 100, 4" DN 125, 5" DN 150, 6" DN 200, 8"	see table 11 see table 11 see table 11 see table 11 see table 11 see table 11 see table 11 see table 11 see table 11 see table 11 see table 11
Process connection rating and style ¹⁾	A1 A2 A3 A4 A5 D2 D4 D5 D6 D7 J1 J2 S2 S4 S8 G9 T9	ASME flange class 150, process connection dim. + facing acc. ASME B16.5 ASME flange class 300, process connection dim. + facing acc. ASME B16.5 ASME flange class 600, process connection dim. + facing acc. ASME B16.5 ASME flange class 900, process connection dim. + facing acc. ASME B16.5 ASME flange class 1500, process connection dim. + facing acc. ASME B16.5 EN flange PN 16, process connection dim. + facing acc. EN 1092-1 Form B1 EN flange PN 40, process connection dim. + facing acc. EN 1092-1 Form B1 EN flange PN 63, process connection dim. + facing acc. EN 1092-1 Form B1 EN flange PN 100, process connection dim. + facing acc. EN 1092-1 Form B1 EN flange PN 160, process connection dim. + facing acc. EN 1092-1 Form B1 JIS flange 10K, JIS B 2220 JIS flange 20K, JIS B 2220 Thread acc. DIN 11851 Clamp, process connection dimensions acc. DIN 32676 Clamp, process connection dim. acc. Tri-Clover® (Tri-Clamp®) and ½" Mini Clamp G, female thread NPT female thread	see table 11 see table 11 see table 11 see table 11 see table 11 see table 11 see table 11 see table 11 see table 11 see table 11 see table 11 see table 11 see table 11 see table 11 see table 11 see table 11 see table 11 see table 11 see table 11
Material of wetted parts ¹⁾	SL HC	Stainless steel 316L (1.4404) Hastelloy C-22 (2.4602)	only RCCT34 to 39/IR

¹⁾ see selection table „Process connection and materials“ (table 11)

Integral Type RCCT3□, Option Code :

Options	Option code	Description	Restrictions
Hazardous Area Approvals	/KF1	ATEX Flame proof converter + Intrinsically safe detector	with /HP not for gas group IIC
	/KF5	ATEX Flame proof converter + Intrinsically safe detector + Intrinsically safe outputs	with /HP not for gas group IIC
	/FF1	FM approval for USA+Canada, Flame proof converter + Intrinsically safe detector + 2 active analog outputs + 2 passive pulse outputs + 1 status input	only with cable conduit "A"; with /HP not for groups A and B
	/FF5	FM approval for USA+Canada, Flame proof converter + Intrinsically safe detector + 2 passive analog outputs + 1 passive pulse output	only with cable conduit "A"; with /HP not for groups A and B
	/EF1	IECEX Flame proof converter + Intrinsically safe detector	with /HP not for gas group IIC
	/EF5	IECEX Flame proof converter + Intrinsically safe detector + Intrinsically safe outputs	with /HP not for gas group IIC
	/UF1	INMETRO Flame proof converter + Intrinsically safe detector	with /HP not for gas group IIC
	/UF5	INMETRO Flame proof converter + Intrinsically safe detector + Intrinsically safe outputs	with /HP not for gas group IIC
	/NF1	NEPSI Flame proof converter + Intrinsically safe detector	with /HP not for gas group IIC; only with /CN
	/NF5	NEPSI Flame proof converter + Intrinsically safe detector + Intrinsically safe outputs	with /HP not for gas group IIC; only with /CN
Custody Transfer Measurement	/GF1	EAC Flame proof converter + Intrinsically safe detector	with /HP not for gas group IIC; only with /VE
	/GF5	EAC Flame proof converter + Intrinsically safe detector + Intrinsically safe outputs	with /HP not for gas group IIC; only with /VE
	/Q01 /Q20 /Q21	European MID Approval (fluids other than water) NTEP approval 12-080A2, Accuracy class 0,3 acc. NIST Handbook 44 NTEP approval 12-080A2, Accuracy class 0,3 acc. NIST Handbook 44, Heated Products	Refer to GS 01R04B07-00E Refer to GS 01R04B07-00E Refer to GS 01R04B07-00E

Integral Type RCCT3□, Option Code (continued)

Options	Option code	Description	Restrictions
GOST	/QR2 /QR3	Primary Calibration and Test Confirmation valid in Kazakhstan Primary Calibration and Test Confirmation valid in Uzbekistan	see page 11; not with /Q20, /Q21; only with /VE see page 11; not with /Q20, /Q21
Dual Seal Approval	/DS /RD	Dual Seal approval (conform with ANSI/ISA-12.27.01) Rupture disk, rupture pressure 20 bar, nominal diameter 8 mm	not with process connection A5 not with RCCT39/XR without option /HT, preferable with /GA, mandatory if /DS+/GA is selected
High Driving Power	/HP	High Driving Power; recommended for RCCT36 to 39, strongly recommended for RCCT39/IR ¹⁾ . Please see „Hazardous Area Specifications“	mandatory for RCCT39/XR
Communication	/FB	Digital communication (FOUNDATION™ Fieldbus protocol)	Refer to GS 01R04B05-00E
	/MB2	Modbus communication protocol for all parameters and values	not with /KF5, /EF5, /UF5, /GF5, /NF5, /FF5, /Q01, /Q20, /Q21, /AP, /NM, /MB3
	/MB3	Modbus communication protocol for all parameters and values incl. HART Communication, analogue output, pulse/status output, status input	not with /KF5, /EF5, /FF5, /UF5, /NF5, /GF5, /Q01, /MB2
Active Pulse Output	/AP	One active pulse output	not with /KF5, /EF5, /FF5, /UF5, /NF5, /GF5, /NM
NAMUR Switch	/NM	One pulse output acc. to EN 60947-5-6 (NAMUR)	not with /AP, not with /KF5, /EF5, /UF5, /NF5, /GF5
Tag Number	/BG	With customer specified tag number on name plate	max. 16 characters; the last 8 significant characters are used for HART® Tag; characters acc. Codepage 850 (Multi-lingual)
HART® Tag Number (Software Tag)	/BT1	With customer specified tag number for HART® communication in converter	22 characters for long tag; characters acc. Codepage 850 (Multi-lingual)
Flange Facing	/DN	Flange with safety grooves acc. to EN 1092-1 form D	only for D2 to D6; not HC
	/EN	Flange with spigot acc. to EN 1092-1 form E	only for D2 to D6; not HC
	/FN	Flange with recess acc. to EN 1092-1 form F	only for D2 to D6; not HC
	/RJ	Ring Type Joint Flanges	only for A3, A4, A5; not HC
Gas Measurement	/GA	Gas measurement, special factory adjustments and settings	to be conform with ANSI/ISA-12.27.01 select /RD; not with /Q20, /Q21
Special Calibration	/K2 ²⁾	Custom 5 pts mass-/volume-flow calibration using water with factory certificate (traceable to German national standards)	only RCCT34 to 39; not with /GA
	/K4	Density adjustment + thermal treatment; (accuracy: 0.001 g/cm ³)	
	/K5 ²⁾	Custom 10 pts mass-/volume-flow calibration using water with DAKS certificate (according EN-17025:2005)	only RCCT34 to 39; not with /GA
	/K6	Density calibration with 3 different fluids incl. individual temperature compensation with certificate (accuracy: 0.0005 g/cm ³)	
Certificates	/P2	Certificate of compliance with the order acc. to EN 10204:2004 -2.1	only for butt weld between process connection and flow divider
	/P3	Test Report acc. to EN 10204:2004-2.2(QIC) including the content of option /P2	
	/P6	Material certificate acc. to EN 10204: 2004 -3.1	
	/P8	Pressure test report measuring system	
	/H1	Oil and fat free for wetted surface acc. to ASTM G93-03 level C	
	/WP	WPS acc. DIN EN ISO 15609-1 (Welding Procedure Specification) WPQR acc. DIN EN ISO 15614-1 (Welding Procedure Qualification Record) WQC acc. DIN EN 287-1 (Welder Qualification Certificate)	
	/L2	Calibration certificate level 2: Declaration and the Calibration Equipment List are issued	
	/L3 /L4	Calibration certificate level 3: Declaration and the Primary Standard List are issued Calibration certificate level 4: Declaration and the Yokogawa Measuring Instruments Control System are issued	
Sanitary Type	/SF1	Surface roughness Ra = 0.8 µm	only RCCT34 to 39; not with RCCT34 /K4 and RCCT34 / K6; only process connections S2, S4, S8;
	/SF2	As /SF1 + Test report roughness of wetted parts	as /SF1
	/SA	As /SF2 + 3A- declaration of conformity and 3A- mark	as /SF1, but not with process connection S2
	/SE	As /SF2 + EHEDG certificate	as /SF1, but not with process connection S2
Customer Presetting	/PS	Presetting sheet with customer data	has to be issued with the order
Housing Pressure Test	/J1	Rupture pressure proof test and certificate (see page 4)	not for RCCT39/XR
X-Ray Examination	/RT	X-ray examination of flange welding	RCCT34 with /K4 or /K6 only one-sided; not with HC
PMI Certificate	/PM6	PMI Test on wetted parts	
Dye Penetrant Test	/PT	Dye Penetrant Test acc. DIN EN ISO 3452-1 at the weldings of the process connection, with certificate	
Epoxy Coating	/X1	Epoxy coating of converter housing	
Concentration Measurement ³⁾	/CST	Standard concentration measurement	not with /GA, /C□□
	/C□□	Advanced concentration measurement, details see table „Advanced Concentration Measurement Options“	not with /GA, /CST
Delivery to Japan	/PJ	For meters which are delivered to Japan, with SI-unit preset	
Delivery to Korea	/KC	With KC-mark for Korea	
Eurasian Conformity	/VE	With EAC- mark	combination with Hazardous Area Approval only with /GF□
Delivery to China	/CN	For delivery to China	combination with Hazardous Area Approval only with /NF□
Version IR	/V2	Version 2	always with RCCT39/IR
Cable glands	/AD2	2 pcs ANSI 1/2" NPT / G1/2 adapter	only with cable conduit 'A'
Instruction Manuals	/IE□	Quantity of instruction manuals in English	□ = 1 to 3 selectable ⁴⁾
	/ID□	Quantity of instruction manuals in German	□ = 1 to 3 selectable ⁴⁾
	/IF□	Quantity of instruction manuals in French	□ = 1 to 3 selectable ⁴⁾
Quick Delivery	/QD	Delivery within 24 hours from factory	Delivery scope please refer to "Quick Delivery Possibilities" or contact Yokogawa sales office.
Special order	/Z	Special design, must be specified separately. If /Z is selected, several Suffix of Model-Suffix Code can be changed to Z.	

¹⁾ For gas application /GA RCCT39/XR can also be ordered without /HP.

²⁾ Calibration order sheet must be delivered with the order. This is available on the Flow Center Page at Coriolis/RCC□3/Technical Information.
Volume calibration: Mass flow calibration converted by density to volume flow.

³⁾ For detailed information please see T1 01R04B04-04E-E. Concentration measurement is recommended with option /K6.

⁴⁾ If no instruction manual is selected, only a DVD with instruction manuals is shipped with the instrument. More than 3 manuals of one language on request available.

Remote Detector RCCS3□, Model and Suffix Code

Model	Suffix Code	Description	Restrictions
RCCS30LR RCCS30 RCCS31 RCCS32 RCCS33 RCCS34 RCCS36 RCCS38 RCCS39 RCCS39/IR RCCS39/XR		Nominal Value : 0.021 t/h = 0.35 kg/min (0.77 lbs/min) Nominal Value : 0.045 t/h = 0.75 kg/min (1.65 lbs/min) Nominal Value : 0.17 t/h = 2.8 kg/min (6.17 lbs/min) Nominal Value : 0.37 t/h = 6.2 kg/min (13.66 lbs/min) Nominal Value : 0.95 t/h = 16 kg/min (35.27 lbs/min) Nominal Value : 3 t/h = 50 kg/min (110.2 lbs/min) Nominal Value : 10 t/h = 170 kg/min (374.78 lbs/min) Nominal Value : 32 t/h = 533 kg/min (1175 lbs/min) Nominal Value : 100 t/h = 1670 kg/min (3681.72 lbs/min) Nominal Value : 250 t/h = 4170 kg/min (9193.27 lbs/min) Nominal Value : 500 t/h = 8340 kg/min (18386.55 lbs/min)	only with /V2 select affiliated RCCF31 or RCCR31 with /HP
Cable conduit connection	-M -A	M20 x 1.5, female thread with cable glands ANSI 1/2" NPT, female thread only with cable gland for detector connection	not with /FS1
Process connection size ¹⁾	41 01 23 02 04 05 06 08 10 12 15 20	1/4" DN 15, 1/2" 3/4" DN 25, 1" DN 40, 1 1/2" DN 50, 2" DN 65, 2 1/2" DN 80, 3" DN 100, 4" DN 125, 5" DN 150, 6" DN 200, 8"	see table 11 see table 11 see table 11 see table 11 see table 11 see table 11 see table 11 see table 11 see table 11 see table 11 see table 11 see table 11
Process connection rating and style ¹⁾	A1 A2 A3 A4 A5 D2 D4 D5 D6 D7 J1 J2 S2 S4 S8 G9 T9	ASME flange class 150, process connection dim. + facing acc. ASME B16.5 ASME flange class 300, process connection dim. + facing acc. ASME B16.5 ASME flange class 600, process connection dim. + facing acc. ASME B16.5 ASME flange class 900, process connection dim. + facing acc. ASME B16.5 ASME flange class 1500, process connection dim. + facing acc. ASME B16.5 EN flange PN 16, process connection dim. + facing acc. EN 1092-1 Form B1 EN flange PN 40, process connection dim. + facing acc. EN 1092-1 Form B1 EN flange PN 63, process connection dim. + facing acc. EN 1092-1 Form B1 EN flange PN 100, process connection dim. + facing acc. EN 1092-1 Form B1 EN flange PN 160, process connection dim. + facing acc. EN 1092-1 Form B1 JIS flange 10K, JIS B 2220 JIS flange 20K, JIS B 2220 Thread acc. DIN 11851 Clamp, process connection dimensions acc. DIN 32676 Clamp, process connection dim. acc. Tri-Clover® (Tri-Clamp®) and 1/2" Mini Clamp G female thread NPT female thread	see table 11 see table 11 see table 11 see table 11 see table 11 see table 11 see table 11 see table 11 see table 11 see table 11 see table 11 see table 11 see table 11 see table 11 see table 11 see table 11 see table 11
Material of wetted parts ¹⁾	SH SL HC	316L (1.4404) and Hastelloy C-22 (2.4602) for tube Stainless steel 316L (1.4404) Hastelloy C-22 (2.4602)	only RCCS30LR to 33 only RCCS34 to 39/XR only RCCS34 to 39/IR

¹⁾ see selection table „Process connection and materials“ (table 11)

Remote Detector RCCS3□, Option Code

Options	Option code	Description	Restrictions
Hazardous Area Approvals ¹⁾	/KS1 /FS1 /ES1 /US1 /NS1 /GS1	ATEX intrinsically safe approval FM intrinsically safe approval for USA + Canada IECEX intrinsically safe approval INMETRO intrinsically safe approval for Brazil NEPSI intrinsically safe approval for China EAC intrinsically safe approval	only with cable conduit 'A' only with /CN only with /VE
Custody Transfer Measurement	/Q01 /Q20 /Q21	European MID Approval (fluids other than water) NTEP approval 12-080A2, Accuracy class 0.3 acc. NIST Handbook 44 NTEP approval 12-080A2, Accuracy class 0.3 acc. NIST Handbook 44, Heated Products	Refer to GS 01R04B07-00E Refer to GS 01R04B07-00E Refer to GS 01R04B07-00E
GOST ¹⁾	/QR2 /QR3	Primary Calibration and Test Confirmation valid in Kazakhstan Primary Calibration and Test Confirmation valid in Uzbekistan	see page 11; not with /Q20, /Q21; only with /VE see page 11; not with /Q20, /Q21
Marine Approval	/MC2 /MC3	Marine approval acc. DNV piping class 2 Marine approval acc. DNV piping class 3	see GS 01R04B10-00E-E see GS 01R04B10-00E-E
Dual Seal Approval	/DS /RD	Dual Seal approval (conform with ANSI/ISA-12.27.01) Rupture disk, rupture pressure 20 bar, nominal diameter 8 mm	only RCCS34 to 39/XR; not with process connection A5 only RCCS34 to 39/IR and RCCS39/XR with /HT, preferable with /GA, not with /T1, /T2, /T3, mandatory if /DS + /GA is selected
Tag Number	/BG	With customer specified tag number on name plate	max. 16 digits
Flange Facing	/DN /EN /FN /RJ	Flange with safety grooves acc. to EN 1092-1 form D Flange with spigot acc. to EN 1092-1 form E Flange with recess acc. to EN 1092-1 form F Ring Type Joint Flanges	only for D2 to D6; not HC, for RCCS30LR only for 01D4 or 01D6 only for D2 to D6; not HC, for RCCS30LR only for 01D4 or 01D6 only for D2 to D6; not HC, for RCCS30LR only for 01D4 or 01D6 only for A3, A4, A5; not HC, for RCCS30LR only for 01A3 or 01A5
Gas Measurement	/GA	Gas measurement, special factory adjustments and settings	select affiliated RCCF31 or RCCR31 with /GA; to be conform with ANSI/ISA-12.27.01 select /RD; not with /Q20
Low temperature version	/LT	$-200^{\circ}\text{C} \leq T_{\text{medium}} \leq 150^{\circ}\text{C}$ (-328°F to 302°F)	for RCCS34 to 39/XR; not with /MT, /HT, /Q01, /T1, /T2, /T3; in combination with Hazardous Area Approval only with /S2
Extended temperature range	/MT	$-70^{\circ}\text{C} \leq T_{\text{medium}} \leq 230^{\circ}\text{C}$ (-94°F to 446°F) $-50^{\circ}\text{C} \leq T_{\text{medium}} \leq 260^{\circ}\text{C}$ (-58°F to 500°F)	for RCCS34 to 39/XR; always with /S2 or /T1, /T2, /T3; for RCCS30LR to 33, always with /S2 or /T1, /T2, /T3
High temperature version	/HT	T_{medium} up to 350°C (662°F)	RCCS34 to 39/XR; only with /T1, /T2, /T3 or /S2 (cus- tomer insulation required); RCCS39/XR only with /S2;
Special Calibration	/K2 ³⁾ /K4 /K5 ³⁾ /K6	Custom 5 pts mass-/volume-flow calibration using water with factory certificate (traceable to German national standards) Density adjustment + thermal treatment; (accuracy: 0.001 g/cm ³) Custom 10 pts mass-/volume-flow calibration using water with DAkkS certificate (according EN-17025:2005) Density calibration with 3 different fluids incl. individual temperature compensation with certificate (accuracy: 0.0005 g/cm ³)	only in combination with converter RCCF31/RCCR31 only RCCS31 to 39; not with /GA only in combination with converter RCCF31/RCCR31 only RCCS32 to 39; not with /GA; not with /LT; not with /MT; only available if converter is also ordered
Certificates	/P2 /P3 /P6 /P8 /H1 /WP /L2 /L3 /L4	Certificate of compliance with the order acc. to EN 10204:2004 -2.1 Test Report acc. to EN10204:2004-2.2(QIC) including the content of option /P2 Material certificate acc to EN 10204: 2004 -3.1 Pressure test report measuring system Oil and fat free for wetted surface acc. to ASTM G93-03 level C WPS acc. DIN EN ISO 15609-1 (Welding Procedure Specification) WPQR acc. DIN EN ISO 15614-1 (Welding Procedure Qualification Record) WQC acc. DIN EN 287-1 (Welder Qualification Certificate) Calibration certificate level 2: Declaration and the Calibration Equipment List are issued Calibration certificate level 3: Declaration and the Primary Standard List are issued Calibration certificate level 4: Declaration and the Yokogawa Measuring Instruments Control System are issued	only for butt weld between process connection and flow divider
Sanitary Type	/SF1 /SF2 /SA /SE	Surface roughness Ra = 0.8 μm As /SF1 + Test report roughness of wetted parts As /SF2 + 3A- declaration of conformity and 3A- mark As /SF2 + EHEDG- certificate	only RCCS34 to 39; not with RCCS34 /K4, RCCS34 / K6 and RCCS34 /LT ; only process connections S2, S4, S8; as /SF1 as /SF1, but not with process connection S2 as /SF1, but not with process connection S2
Mounting set	/PD	2 inch pipe mounting set, recommended for RCCS30LR and RCCS30	only RCCS30LR to 33; not with /T□
Housing Pressure Test	/J1	Rupture pressure proof test and certificate (see page 4)	not for RCCS30LR to 33 + RCCS39/XR
Customer insulation / Heating	/S2	Terminal box on extension for high or low process temperature	not with /T1, /T2, /T3
Factory Insulating / Heating	/T1 /T2 /T3	Insulation Insulation + Heat carrier heating Insulation + Heat carrier heating with ventilation (purge)	not for RCCS39/XR not for RCCS39/XR not for RCCS39/XR
X-Ray Examination	/RT	X-ray examination of flange welding	RCCS30LR to 33 and RCCS34 with /K4, /K6 or /LT only one-sided; not with HC
PMI Certificate	/PM4 /PM6	PMI Test on wetted parts RCCS30LR to 33 ⁴⁾ PMI Test on wetted parts RCCS34 to 39/XR	not RCCS34 to 39/XR not RCCS30LR to 33
Dye Penetrant Test	/PT	Dye Penetrant Test acc. DIN EN ISO 3452-1 at the weldings of the process connection, with certificate	
Stainless steel cable gland	/BS	Cable gland stainless steel	
Version IR	/V2	Version 2	always with RCCS39/IR
Delivery to Japan	/PJ	For meters which are delivered to Japan	
Delivery to Korea	/KC	With KC-mark for Korea	
Eurasian Conformity	/VE	With EAC- mark	combination with Hazardous Area Approval only with /GS1
Delivery to China	/CN	For meters which are delivered to China	combination with Hazardous Area Approval only with /NS1
Quick Delivery	/QD	Delivery within 24 hours from factory	Delivery scope please refer to "Quick Delivery Possibili- ties" or contact Yokogawa sales office.
Special order	/Z	Special design, must be specified separately. If /Z is selected, several Suffix of Model-Suffix Code can be changed to Z.	

¹⁾ Select affiliated converter RCCF31/RCCR31 with the same approval type (e.g. ATEX).

²⁾ Select affiliated converter RCCF31 with the same approval type (/Q01, /Q20 or /Q21).

³⁾ Calibration order sheet must be delivered with the order. This is available on the Flow Center Page at Coriolis/RCC□3/Technical Information.

Volume calibration: Mass flow calibration converted by density to volume flow.

⁴⁾ Measuring tube PMI test is performed per delivery batch.

Remote field-mount Converter RCCF31, Model, Suffix and Option Code

Model	Suffix Code	Option Code	Description	Restrictions
RCCF31			Remote field-mount converter to be connected to RCCS3; when ordered without detector combination option /NC must be selected	
Power supply	-A -D		90 - 264 V AC 24 V DC	
Indicator direction	H2 N0		With indicator Without indicator	
Cable conduit connection	M A		M20 x 1.5, female thread with cable glands ANSI 1/2" NPT, female thread, only cable gland for detector connection	not with /FF1, /FF5
Hazardous Area Approvals ¹⁾	/KF1 /KF5 /FF1 /FF5 /EF1 /EF5 /UF1 /UF5 /NF1 /NF5 /GF1 /GF5		ATEX Flame proof converter + Intrinsically safe detector output ATEX Flame proof converter + Intrinsically safe detector output + Intrinsically safe outputs 2 passive analog output + 1 passive pulse output FM approval for USA+Canada, Flame proof converter + Intrinsically safe detector output + 2 active analog outputs + 2 passive pulse outputs + 1 status input FM approval for USA+Canada, Flame proof converter + Intrinsically safe detector output + 2 passive analog outputs + 1 passive pulse output IECEX Flame proof converter + Intrinsically safe detector output IECEX Flame proof converter + Intrinsically safe detector output + Intrinsically safe outputs 2 passive analog output + 1 passive pulse output INMETRO Flame proof converter + Intrinsically safe detector output INMETRO Flame proof converter + Intrinsically safe detector output + Intrinsically safe outputs 2 passive analog output + 1 passive pulse output NEPSI Flame proof converter + Intrinsically safe detector output NEPSI Flame proof converter + Intrinsically safe detector output + Intrinsically safe outputs 2 passive analog output + 1 passive pulse output EAC Flame proof converter + Intrinsically safe detector output EAC Flame proof converter + Intrinsically safe detector output + Intrinsically safe outputs 2 passive analog output + 1 passive pulse output	with /HP not for gas group IIC with /HP not for gas group IIC only with cable conduit "A"; with /HP not for groups A and B only with cable conduit "A"; with /HP not for groups A and B with /HP not for gas group IIC with /HP not for gas group IIC with /HP not for gas group IIC with /HP not for gas group IIC with /HP not for gas group IIC; only with /CN with /HP not for gas group IIC; only with /CN with /HP for gas group IIB; only with /VE with /HP for gas group IIB; only with /VE
Custody Transfer Measurement	/Q01 /Q20 /Q21		European MID Approval (fluids other than water) NTEP approval 12-080A2, Accuracy class 0,3 acc. NIST Handbook 44 NTEP approval 12-080A2, Accuracy class 0,3 acc. NIST Handbook 44, Heated Products	Refer to GS 01R04B07-00E Refer to GS 01R04B07-00E Refer to GS 01R04B07-00E
GOST ¹⁾	/QR2 /QR3		Primary Calibration and Test Confirmation valid in Kazakhstan Primary Calibration and Test Confirmation valid in Uzbekistan	see page 11; not with /Q20, /Q21; only with /VE see page 11; not with /Q20, /Q21
Marine Approval	/MC2 /MC3		Marine approval acc. DNV piping class 2 Marine approval acc. DNV piping class 3	see GS 01R04B10-00E-E see GS 01R04B10-00E-E
High Driving Power	/HP		High Driving Power, recommended for combination with RCCS36 to 39, strongly recommended for combination with RCCS39/IR, Please see „ Hazardous Area Specifications“	mandatory for combination with RCCS39/XR ⁵⁾
Communication	/FB /MB2 /MB3		Digital communication (FOUNDATION™ Fieldbus protocol) Modbus communication protocol for all parameters and values Modbus communication protocol for all parameters and values incl. HART Communication, analogue output, pulse/status output, status input	refer to GS 01R04B05-00E not with /KF5, /EF5, /UF5, /GF5, /NF5, /FF5, /Q01, /Q20, /Q21, /AP, /NM, /MB3 not with /KF5, /EF5, /FF5, /UF5, /NF5, /GF5, /Q01, /MB2
Active Pulse Output	/AP		One active pulse output	not with /KF5, /EF5, /FF5, /UF5, /NF5, /GF5, /NM
NAMUR Switch	/NM		One pulse output acc. to EN 60947-5-6 (NAMUR)	not with /AP, not with /KF5, /EF5, /UF5, /NF5, /GF5
Tag Number	/BG		With customer specified tag number on name plate	max. 16 characters; the last 8 significant characters are used for HART® Tag; characters acc. Codepage 850 (Multi-lingual)
HART® Tag Number (Software Tag)	/BT1		With customer specified tag number for HART® communication in converter	22 characters for long tag; characters acc. Codepage 850 (Multi-lingual)
Gas Measurement	/GA		Gas measurement, special factory adjustments and settings	select affiliated RCCS3 <input type="checkbox"/> with /GA; not with /Q20, /Q21
Combination with RCCS39/XR	/XR		Special converter adjustment with RCCS39/XR	mandatory for combination with RCCS39/XR
No Combination	/NC		No combination with detector	
Customer Presetting	/PS		Presetting sheet with customer data	has to be issued with the order
Epoxy Coating	/X1		Epoxy coating of converter housing	
Delivery to Japan	/PJ		For meters which are delivered to Japan with SI-unit preset	
Delivery to Korea	/KC		With KC-mark for Korea	
Eurasian Conformity	/VE		With EAC- mark	combination with Hazardous Area Approval only with /GF <input type="checkbox"/>
Delivery to China	/CN		For meters which are delivered to China	combination with Hazardous Area Approval only with /NF <input type="checkbox"/>
Cable glands	/AD2		2 pcs ANSI 1/2" NPT / G1/2 adapter	only with cable conduit "A"
Concentration Measurement ³⁾	/CST /C <input type="checkbox"/>		Standard concentration measurement Advanced concentration measurement, details see table „Advanced Concentration Measurement Options“	not with /GA, /C <input type="checkbox"/> not with /GA, /CST
Certificates	/P2 /P3		Certificate of compliance with the order acc. to EN 10204:2004 -2.1 Test Report acc. to EN10204:2004-2.2(QIC) including the content of option /P2	
Instruction Manuals	/IE <input type="checkbox"/> /ID <input type="checkbox"/> /IF <input type="checkbox"/>		Quantity of instruction manuals in English Quantity of instruction manuals in German Quantity of instruction manuals in French	<input type="checkbox"/> = 1 to 3 selectable ⁴⁾ <input type="checkbox"/> = 1 to 3 selectable ⁴⁾ <input type="checkbox"/> = 1 to 3 selectable ⁴⁾
Quick Delivery	/QD		Delivery within 24 hours from factory	Delivery scope please refer to "Quick Delivery Possibilities" or contact Yokogawa sales office.
Special order	/Z		Special design, must be specified separately. If /Z is selected, several Suffix of Model-Suffix Code can be changed to Z.	

¹⁾ Select affiliated RCCS3 with the same approval type (e.g. /KF with /KS1).

²⁾ Select affiliated RCCS3 with the same approval type (/Q01, /Q20 or /Q21).

³⁾ For detailed information please see TI 01R04B04-04E-E. Option /K6 of RCCS3 is recommended with concentration measurement.

⁴⁾ If no instruction manual is selected, only a DVD with instruction manuals is shipped with the instrument. More than 3 manuals of one language on request available.

⁵⁾ RCCF31 in combination with RCCS39/XR with gas application /GA can also be ordered without /HP.

Remote rack-mount Converter RCCR31, Model, Suffix and Option Code

Model	Suffix Code	Option Code	Description	Restrictions
RCCR31			Remote converter for 19" rack mounting to be connected to RCCS3	
Power supply	-A -D		90 - 264 V AC 24 V DC	
Hazardous Area Approvals ¹⁾	/KS1 /FS1 /ES1 /US1 /NS1 /GS1		ATEX associated apparatus for intrinsically safe detector connection for gas group IIC FM associated apparatus for intrinsically safe detector output IECEX associated apparatus for intrinsically safe detector output for gas group IIC INMETRO associated apparatus for intrinsically safe detector output for gas group IIC NEPSI associated apparatus for intrinsically safe detector output for gas group IIC EAC associated apparatus for intrinsically safe detector connection for gas group IIC	with /HP not for gas group IIC with /HP not for gas groups A and B with /HP not for gas group IIC with /HP not for gas group IIC with /HP not for gas group IIC; only with /CN with /HP not for gas group IIC; only with /VE
GOST ¹⁾	/QR2		Primary Calibration and Test Confirmation valid in Kazakhstan	see page 11; only with /VE
Marine Approval	/MC2 /MC3		Marine approval acc. DNV piping class 2 Marine approval acc. DNV piping class 3	see GS 01R04B10-00E-E see GS 01R04B10-00E-E
High Driving Power	/HP		High Driving Power, recommended for combination with RCCS36 to 39, strongly recommended for combination with RCCS39/IR, Please see „ Hazardous Area Specifications“	mandatory for combination with RCCS39/XR
Active Pulse Output	/AP		One active pulse output	not with /NM
NAMUR Switch	/NM		One pulse output acc. EN 60947-5-6 (NAMUR)	not with /AP
Tag Number	/BG		With customer specified tag number on name plate	max. 16 characters; the last 8 significant characters are used for HART® Tag; characters acc. Codepage 850 (Multi-lingual)
HART® Tag Number (Software Tag)	/BT1		With customer specified tag number for HART® communication in converter	22 characters for long tag; characters acc. Codepage 850 (Multi-lingual)
Communication	/MB2 /MB3		Modbus communication protocol for all parameters and values Modbus communication protocol for all parameters and values incl. HART Communication, analogue output, pulse/status output, status input	not with /AP, /NM, /MB3 not with /MB2
Gas Measurement	/GA		Gas measurement, special factory adjustments and settings	select affiliated RCCS3 with /GA
Combination with RCCS39/XR	/XR		Special converter adjustment with RCCS39/XR	mandatory for combination with RCCS39/XR
No Combination	/NC		No combination with detector	
Customer Presetting	/PS		Presetting sheet with customer data	has to be issued with the order
Concentration Measurement ²⁾	/CST /C□□		Standard concentration measurement Advanced concentration measurement, details see table „Advanced Concentration Measurement Options“	not with /GA, /C□□ not with /GA, /CST
Subrack	/SR2 /SR4		Subrack for 2 converter RCCR31 with mounting Subrack for 4 converter RCCR31 with mounting	
Delivery to Korea	/KC		With KC-mark for Korea	
Eurasian Conformity	/VE		With EAC- mark	combination with Hazardous Area Approval only with /GS1
Delivery to China	/CN		For meters which are delivered to China	combination with Hazardous Area Approval only with /NS1
Certificates	/P2 /P3		Certificate of compliance with the order acc. to EN 10204:2004 -2.1 Test Report acc. to EN10204:2004-2.2(QIC) including the content of option /P2	
Instruction Manuals	/IE□ /ID□ /IF□		Quantity of instruction manuals in English Quantity of instruction manuals in German Quantity of instruction manuals in French	□ = 1 to 3 selectable ³⁾ □ = 1 to 3 selectable ³⁾ □ = 1 to 3 selectable ³⁾
Special order	/Z		Special design, must be specified separately. If /Z is selected, several Suffix of Model-Suffix Code can be changed to Z.	

¹⁾ Select affiliated RCCS3 with the same approval type (e.g. /KS1 with /KS1).
²⁾ For detailed information please see T1 01R04B04-04E-E. Option /K6 of RCCS3 is recommended with concentration measurement.
³⁾ If no instruction manual is selected, only a DVD with instruction manuals is shipped with the instrument. More than 3 manuals of one language on request available.
⁴⁾ RCCR31 in combination with RCCS39/XR with gas application /GA can also be ordered without /HP.

Remote Cable RCCY03□, Model, Suffix and Option Code

Model	Suffix Code	Option Code	Description	Restrictions
RCCY031 RCCY032 RCCY033 RCCY034			Length in "meter" Length in "feet" Length in "meter" Length in "feet"	max. ambient temperature 70°C (158°F); with /FF□ or /FS1: 50°C (122°F) max. ambient temperature 70°C (158°F); with /FF□ or /FS1: 50°C (122°F) max. ambient temperature 105°C (221°F); with /FF□ or /FS1: 85°C (185°F) max. ambient temperature 105°C (221°F); with /FF□ or /FS1: 85°C (185°F)
Cable ends	-0 -1		No termination, with one termination kit Terminated	
Cable length	L□□□		Enter the length	max. 300m / 999ft, the following lengths can be ordered (e.g. 3m = L003): RCCY031-0: 3m, 5m, 10m, 15m, 30m, 50m, 100m, 150m, 200m, 250m, 300m RCCY031-1: 3m, 5m, 10m, 15m, 30m, 50m RCCY032-0: 10ft, 15ft, 30ft, 50ft, 100ft, 150ft, 300ft, 500ft, 1000ft RCCY032-1: 10ft, 15ft, 30ft, 50ft, 100ft, 150ft RCCY033-0: 3m, 5m, 10m, 15m, 30m, 50m, 100m, 150m, 300m RCCY033-1: 3m, 5m, 10m, 15m, 30m, 50m RCCY034-0: 10ft, 15ft, 30ft, 50ft, 100ft, 150ft, 300ft, 500ft, 1000ft RCCY034-1: 10ft, 15ft, 30ft, 50ft, 100ft, 150ft
Options: Hazardous area installation Termination kits Delivery to China Quick delivery	/KS1 /NS1 /TK□□ /CN /QD		Blue cable for Ex-i indication Blue cable for Ex-i indication (China) Quantity of additional termination kits For meters which are delivered to China Delivery within 24 hours from factory	only with /CN □□ = 01 to 99 combination with Hazardous Area Approval only with /NS1 only L003, L005, L010

Advanced Concentration Measurement Options (others on request), recommended with Option /K6

Option	Display	Components	Concentration range	Temp. range	Source of concentration- / density table
/C00	---	---	---	---	Advanced concentration measurement function. There are no pre-defined concentration setups (coefficients are set to zero). The concentration coefficients will be set by customer making use of either FieldMate or the stand- alone concentration tool and manual entry by HHT. For more information, please contact your regional Yokogawa office.
/C01	°Brix	Sugar / Water	0 - 85 °Brix	0 - 80°C (32 - 176°F)	PTB- Messages 100 5/90: „The density of watery Saccharose solutions after the introduction of the international temperature scale of 1990 (ITS1990)“ Table 5
/C02	WT%	NaOH / Water	2 - 50 WT%	0 - 100°C (32 - 212°F)	D'Ans-Lax, Handbook for chemists and physicists Vol.1, 3rd edition, 1967
/C03	WT%	KOH / Water	0 - 60 WT%	54 - 100°C (129 - 212°F)	D'Ans-Lax, Handbook for chemists and physicists Vol.1, 3rd edition, 1967
/C04	WT%	NH ₄ NO ₃ / Water	1 - 50 WT%	0 - 80°C (32 - 176°F)	Data table on request
/C05	WT%	NH ₄ NO ₃ / Water	20 - 70 WT%	20 - 100°C (68 - 212°F)	Data table on request
/C06 ¹⁾	WT%	HCl / Water	22 - 34 WT%	20 - 40°C (68 - 104°F)	D'Ans-Lax, Handbook for chemists and physicists Vol.1, 3rd edition, 1967
/C07	WT%	HNO ₃ / Water	50 - 67 WT%	10 - 60°C (50 - 140°F)	Data table on request
/C09	WT%	H ₂ O ₂ / Water	30 - 75 WT%	4 - 44°C (39.2 - 111.2°F)	Data table on request
/C10	WT%	Ethylene Glycol / Water	10 - 50 WT%	-20 - 40°C (-4 - 104°F)	Data table on request
/C11	WT%	Amylum = starch / Water	33 - 43 WT%	35 - 45°C (95 - 113°F)	Data table on request
/C12	WT%	Methanol / Water	35 - 60 WT%	0 - 40°C (32 - 104°F)	Data table on request
/C20	VOL%	Alcohol / Water	55 - 100 VOL%	10 - 40°C (50 - 104°F)	Data table on request
/C21	°Brix	Sugar / Water	40 - 80 °Brix	75 - 100°C (167 - 212°F)	Data table on request
/C30	WT%	Alcohol / Water	66 - 100 WT%	15 - 40°C (59 - 104°F)	Standard Copersucar 1967
/C37	WT%	Alcohol / Water	66 - 100 WT%	10 - 40°C (50 - 104°F)	Brazilian Standard ABNT
/C38	VOL%	Alcohol / Water	73 - 100 VOL%	10 - 40°C (50 - 104°F)	Brazilian Standard ABNT

¹⁾ only with material HC

Table 11 : Selection Table Process Connection and Materials, Installation Length in mm

		RCCS 30LR		RCCS 30-33		RCCS34 RCCT34		RCCS36 RCCT36		RCCS38 RCCT38		RCCS39 RCCT39		RCCS39/IR RCCT39/IR		RCCS39/XR RCCT39/XR	
		SH	SH	SL	HC	SL	HC	SL	HC	SL	HC	SL	HC	SL	HC	SL	HC
Flanges according to ASME B16.5	01A1	½"-150	240	240	370	----	----	----	----	----	----	----	----	----	----	----	----
	01A2	½"-300	240	240	370	----	----	----	----	----	----	----	----	----	----	----	----
	01A3	½"-600	250	250	380	----	----	----	----	----	----	----	----	----	----	----	----
	01A4	½"-900	----	----	400	----	----	----	----	----	----	----	----	----	----	----	----
	01A5	½"-900/1500	270	270	400	----	----	----	----	----	----	----	----	----	----	----	----
	02A1	1"-150	----	240	370	390	500	----	----	----	----	----	----	----	----	----	----
	02A2	1"-300	----	240	370	390	500	----	----	----	----	----	----	----	----	----	----
	02A3	1"-600	----	260	390	390	520	----	----	----	----	----	----	----	----	----	----
	02A4	1"-900	----	----	450	400	540	----	----	----	----	----	----	----	----	----	----
	02A5	1"-900/1500	----	320	450	400	540	----	----	----	----	----	----	----	----	----	----
	04A1	1½"-150	----	250	380	390	500	520	600	----	----	----	----	----	----	----	----
	04A2	1½"-300	----	250	380	390	510	520	600	----	----	----	----	----	----	----	----
	04A3	1½"-600	----	270	400	400	530	530	620	----	----	----	----	----	----	----	----
	04A4	1½"-900	----	----	470	----	600	----	640	----	----	----	----	----	----	----	----
	04A5	1½"-900/1500	----	340	470	----	600	----	----	----	----	----	----	----	----	----	----
	05A1	2"-150	----	----	----	390	510	520	600	620	----	----	----	----	----	----	----
	05A2	2"-300	----	----	----	390	510	520	600	620	----	----	----	----	----	----	----
	05A3	2"-600	----	----	----	400	540	540	630	630	----	----	----	----	----	----	----
	05A4	2"-900	----	----	----	----	660	----	720	----	----	----	----	----	----	----	----
	05A5	2"-900/1500	----	----	----	----	660	----	----	----	----	----	----	----	----	----	----
	06A1	2½"-150	----	----	----	----	----	----	610	620	----	----	----	----	----	----	----
	06A2	2½"-300	----	----	----	----	----	----	610	620	----	----	----	----	----	----	----
	06A3	2½"-600	----	----	----	----	----	----	640	640	----	----	----	----	----	----	----
	06A4	2½"-900	----	----	----	----	----	----	760	----	----	----	----	----	----	----	----
	08A1	3"-150	----	----	----	----	----	----	610	620	1000	1020	----	----	----	----	----
	08A2	3"-300	----	----	----	----	----	----	620	620	1000	1020	----	----	----	----	----
	08A3	3"-600	----	----	----	----	----	----	640	640	1000	1025	----	----	----	----	----
	08A4	3"-900	----	----	----	----	----	----	760	----	----	----	----	----	----	----	----
	10A1	4"-150	----	----	----	----	----	----	----	----	1000	1020	1100	----	----	----	----
	10A2	4"-300	----	----	----	----	----	----	----	----	1000	1020	1100	----	----	----	----
10A3	4"-600	----	----	----	----	----	----	----	----	1030	1030	1100	----	----	----	----	
12A1	5"-150	----	----	----	----	----	----	----	----	1000	1020	1100	1100	----	----	----	
12A2	5"-300	----	----	----	----	----	----	----	----	1000	1020	1100	1100	----	----	----	
12A3	5"-600	----	----	----	----	----	----	----	----	1040	1040	1160	1110	----	----	----	
15A1	6"-150	----	----	----	----	----	----	----	----	----	----	1100	1100	1350	----	----	
15A2	6"-300	----	----	----	----	----	----	----	----	----	----	1100	1100	1350	----	----	
15A3	6"-600	----	----	----	----	----	----	----	----	----	----	1200	1120	1390	----	----	
20A1	8"-150	----	----	----	----	----	----	----	----	----	----	1140	1100	1350	----	----	
20A2	8"-300	----	----	----	----	----	----	----	----	----	----	1140	1100	1350	----	----	
20A3	8"-600	----	----	----	----	----	----	----	----	----	----	----	----	1440	----	----	
Flanges according to EN 1092-1	01D4	DN 15 PN 40	240	240	370	----	----	----	----	----	----	----	----	----	----	----	----
	01D6	DN 15 PN 100	250	250	380	----	----	----	----	----	----	----	----	----	----	----	----
	02D4	DN 25 PN 40	----	240	370	390	500	520	----	----	----	----	----	----	----	----	----
	02D6	DN 25 PN 100	----	260	390	----	520	----	----	----	----	----	----	----	----	----	----
	04D4	DN 40 PN 40	----	240	370	390	500	520	600	----	----	----	----	----	----	----	----
	04D6	DN 40 PN 100	----	320	450	----	560	----	620	----	----	----	----	----	----	----	----
	05D4	DN 50 PN 40	----	----	----	----	500	520	600	620	----	----	----	----	----	----	----
	05D5	DN 50 PN 63	----	----	----	----	520	----	620	----	----	----	----	----	----	----	----
	05D6	DN 50 PN 100	----	----	----	----	590	----	660	----	----	----	----	----	----	----	----
	05D7	DN 50 PN 160	----	----	----	----	590	----	660	----	----	----	----	----	----	----	----
	08D4	DN 80 PN 40	----	----	----	----	----	----	610	620	1000	1020	----	----	----	----	----
	08D5	DN 80 PN 63	----	----	----	----	----	----	620	----	1000	----	----	----	----	----	----
	08D6	DN 80 PN 100	----	----	----	----	----	----	730	----	1000	----	----	----	----	----	----
	10D2	DN 100 PN 16	----	----	----	----	----	----	----	----	1000	----	1100	----	----	----	----
	10D4	DN 100 PN 40	----	----	----	----	----	----	----	----	1000	1020	1100	----	----	----	----
	10D5	DN 100 PN 63	----	----	----	----	----	----	----	----	1000	----	1100	----	----	----	----
	10D6	DN 100 PN 100	----	----	----	----	----	----	----	----	1050	----	1100	----	----	----	----
	12D2	DN 125 PN 16	----	----	----	----	----	----	----	----	1000	1020	1100	1100	----	----	----
	12D4	DN 125 PN 40	----	----	----	----	----	----	----	----	1000	1020	1100	1100	----	----	----
	12D5	DN 125 PN 63	----	----	----	----	----	----	----	----	1000	----	1100	1100	----	----	----
	12D6	DN 125 PN 100	----	----	----	----	----	----	----	----	1100	----	1140	1100	----	----	----
	12D7	DN 125 PN 160	----	----	----	----	----	----	----	----	----	----	1100	----	----	----	----
	15D2	DN 150 PN 16	----	----	----	----	----	----	----	----	----	----	1100	1100	1350	----	----
	15D4	DN 150 PN 40	----	----	----	----	----	----	----	----	----	----	1100	1100	1350	----	----
	15D5	DN 150 PN 63	----	----	----	----	----	----	----	----	----	----	1140	----	1350	----	----
15D6	DN 150 PN 100	----	----	----	----	----	----	----	----	----	----	1180	----	----	----	----	
20D2	DN 200 PN 16	----	----	----	----	----	----	----	----	----	----	----	----	1350	----	----	
20D4	DN 200 PN 40	----	----	----	----	----	----	----	----	----	----	----	----	1350	----	----	
20D5	DN 200 PN 63	----	----	----	----	----	----	----	----	----	----	----	----	1350	----	----	

Table 11 : Selection Table Process Connection and Materials, Installation Length in mm (continued)

			RCCS	RCCS	RCCS34		RCCS36		RCCS38		RCCS39		RCCS39		RCCS39	
			30LR	30-33	RCCT34	RCCT36	RCCT38	RCCT39	RCCT39/IR	RCCT39/XR						
			SH	SH	SL	HC	SL	HC	SL	HC	SL	HC	SL	HC	SL	HC
Flanges according to JIS B 2220	01J1	DN 15 10K	240	240	370	----	----	----	----	----	----	----	----	----	----	----
	01J2	DN 15 20K	240	240	370	----	----	----	----	----	----	----	----	----	----	----
	02J1	DN 25 10K	----	240	370	390	500	----	----	----	----	----	----	----	----	----
	02J2	DN 25 20K	----	240	370	390	500	----	----	----	----	----	----	----	----	----
	04J1	DN 40 10K	----	240	370	390	500	520	600	----	----	----	----	----	----	----
	04J2	DN 40 20K	----	240	370	390	500	520	600	----	----	----	----	----	----	----
	05J1	DN 50 10K	----	----	----	----	500	520	600	620	----	----	----	----	----	----
	05J2	DN 50 20K	----	----	----	----	500	520	600	620	----	----	----	----	----	----
	08J1	DN 80 10K	----	----	----	----	----	----	600	620	1000	1020	----	----	----	----
	08J2	DN 80 20K	----	----	----	----	----	----	610	620	1000	1020	----	----	----	----
	10J1	DN 100 10K	----	----	----	----	----	----	----	----	1000	1020	1100	----	----	----
	10J2	DN 100 20K	----	----	----	----	----	----	----	----	1000	1020	1100	----	----	----
	12J1	DN 125 10K	----	----	----	----	----	----	----	----	1000	1020	1100	1100	----	----
	12J2	DN 125 20K	----	----	----	----	----	----	----	----	1000	1020	1100	1100	----	----
	15J1	DN 150 10K	----	----	----	----	----	----	----	----	----	----	1100	1100	----	----
15J2	DN 150 20K	----	----	----	----	----	----	----	----	----	----	1100	1100	----	----	
Clamp DIN	01S4	DN 15	240	240	----	----	----	----	----	----	----	----	----	----	----	----
	02S4	DN 25	----	240	370	----	----	----	----	----	----	----	----	----	----	----
	04S4	DN 40	----	240	370	----	500	----	----	----	----	----	----	----	----	----
	05S4	DN 50	----	----	----	----	500	----	600	----	----	----	----	----	----	----
	06S4	DN 65	----	----	----	----	----	----	600	----	----	----	----	----	----	----
	10S4	DN 100	----	----	----	----	----	----	----	----	1000	----	----	----	----	----
	Tri-Clamp	01S8	½"	240	240	----	----	----	----	----	----	----	----	----	----	----
02S8		1"	----	240	370	----	----	----	----	----	----	----	----	----	----	----
04S8		1½"	----	240	370	----	500	----	----	----	----	----	----	----	----	----
05S8		2"	----	----	----	----	500	----	600	----	----	----	----	----	----	----
08S8		3"	----	----	----	----	----	----	600	----	----	----	----	----	----	----
10S8		4"	----	----	----	----	----	----	----	----	1000	----	----	----	----	----
DIN11851	02S2	DN 25	----	240	370	----	----	----	----	----	----	----	----	----	----	----
	04S2	DN 40	----	----	----	----	500	----	----	----	----	----	----	----	----	----
	05S2	DN 50	----	----	----	----	----	----	600	----	----	----	----	----	----	----
	10S2	DN 100	----	----	----	----	----	----	----	----	1000	----	----	----	----	----
Thread	41G9	G¼" female	260	260	----	----	----	----	----	----	----	----	----	----	----	----
	01G9	G½" female	260	260	390	----	----	----	----	----	----	----	----	----	----	----
	23G9	G¾" female	260	260	390	----	----	----	----	----	----	----	----	----	----	----
	41T9	NPT¼" female	260	260	----	----	----	----	----	----	----	----	----	----	----	----
	01T9	NPT½" female	260	260	390	----	----	----	----	----	----	----	----	----	----	----
	23T9	NPT¾" female	260	260	390	----	----	----	----	----	----	----	----	----	----	----

Table 11 : Selection Table Process Connection and Materials, Installation Length in inch

		RCCS	RCCS	RCCS34		RCCS36		RCCS38		RCCS39		RCCS39/IR		RCCS39/XR	
		30LR	30-33	RCCT34		RCCT36		RCCT38		RCCT39		RCCT39/IR		RCCT39/XR	
		SH	SH	SL	HC	SL	HC	SL	HC	SL	HC	SL	HC	SL	HC
Flanges according to ASME B16.5	01A1	½"-150	9.45	9.45	14.57	----	----	----	----	----	----	----	----	----	----
	01A2	½"-300	9.45	9.45	14.57	----	----	----	----	----	----	----	----	----	----
	01A3	½"-600	9.84	9.84	14.96	----	----	----	----	----	----	----	----	----	----
	01A4	½"-900	----	----	15.75	----	----	----	----	----	----	----	----	----	----
	01A5	½"-900/1500	10.63	10.63	15.75	----	----	----	----	----	----	----	----	----	----
	02A1	1"-150	----	9.45	14.57	15.35	19.69	----	----	----	----	----	----	----	----
	02A2	1"-300	----	9.45	14.57	15.35	19.69	----	----	----	----	----	----	----	----
	02A3	1"-600	----	10.24	15.35	15.35	20.47	----	----	----	----	----	----	----	----
	02A4	1"-900	----	----	17.72	15.75	21.26	----	----	----	----	----	----	----	----
	02A5	1"-900/1500	----	12.6	17.72	15.75	21.26	----	----	----	----	----	----	----	----
	04A1	1½"-150	----	9.84	14.96	15.35	19.69	20.47	23.62	----	----	----	----	----	----
	04A2	1½"-300	----	9.84	14.96	15.35	20.08	20.47	23.62	----	----	----	----	----	----
	04A3	1½"-600	----	10.63	15.75	15.75	20.87	20.87	24.21	----	----	----	----	----	----
	04A4	1½"-900	----	----	18.5	----	23.62	----	25.2	----	----	----	----	----	----
	04A5	1½"-900/1500	----	13.39	18.5	----	23.62	----	----	----	----	----	----	----	----
	05A1	2"-150	----	----	----	15.35	20.08	20.47	23.62	24.21	----	----	----	----	----
	05A2	2"-300	----	----	----	15.35	20.08	20.47	23.62	24.21	----	----	----	----	----
	05A3	2"-600	----	----	----	15.75	21.26	21.26	24.8	24.8	----	----	----	----	----
	05A4	2"-900	----	----	----	----	25.98	----	28.35	----	----	----	----	----	----
	05A5	2"-900/1500	----	----	----	----	25.98	----	----	----	----	----	----	----	----
	06A1	2½"-150	----	----	----	----	----	----	24.02	24.21	----	----	----	----	----
	06A2	2½"-300	----	----	----	----	----	----	24.02	24.21	----	----	----	----	----
	06A3	2½"-600	----	----	----	----	----	----	25.2	25.2	----	----	----	----	----
	06A4	2½"-900	----	----	----	----	----	----	29.92	----	----	----	----	----	----
	08A1	3"-150	----	----	----	----	----	----	24.02	24.21	39.37	40.16	----	----	----
	08A2	3"-300	----	----	----	----	----	----	24.21	24.21	39.37	40.16	----	----	----
	08A3	3"-600	----	----	----	----	----	----	25.2	25.2	39.37	40.35	----	----	----
	08A4	3"-900	----	----	----	----	----	----	29.92	----	----	----	----	----	----
	10A1	4"-150	----	----	----	----	----	----	----	----	39.37	40.16	43.31	----	----
	10A2	4"-300	----	----	----	----	----	----	----	----	39.37	40.16	43.31	----	----
10A3	4"-600	----	----	----	----	----	----	----	----	40.55	40.55	43.31	----	----	
12A1	5"-150	----	----	----	----	----	----	----	----	39.37	40.16	43.31	43.31	----	
12A2	5"-300	----	----	----	----	----	----	----	----	39.37	40.16	43.31	43.31	----	
12A3	5"-600	----	----	----	----	----	----	40.94	40.94	45.67	43.31	----	----	----	
15A1	6"-150	----	----	----	----	----	----	----	----	43.31	43.31	53.15	----	----	
15A2	6"-300	----	----	----	----	----	----	----	----	43.31	43.31	53.15	----	----	
15A3	6"-600	----	----	----	----	----	----	----	----	47.2	43.31	54.72	----	----	
20A1	8"-150	----	----	----	----	----	----	----	----	44.9	43.31	53.15	----	----	
20A2	8"-300	----	----	----	----	----	----	----	----	44.9	43.31	53.15	----	----	
20A3	8"-600	----	----	----	----	----	----	----	----	----	----	56.69	----	----	
Flanges according to EN 1092-1	01D4	DN 15 PN 40	9.45	9.45	14.57	----	----	----	----	----	----	----	----	----	----
	01D6	DN 15 PN 100	9.84	9.84	14.96	----	----	----	----	----	----	----	----	----	----
	02D4	DN 25 PN 40	----	9.45	14.57	15.35	19.69	20.47	----	----	----	----	----	----	----
	02D6	DN 25 PN 100	----	10.24	15.35	----	20.47	----	----	----	----	----	----	----	----
	04D4	DN 40 PN 40	----	9.45	14.57	15.35	19.69	20.47	23.62	----	----	----	----	----	----
	04D6	DN 40 PN 100	----	12.6	17.72	----	22.05	----	24.41	----	----	----	----	----	----
	05D4	DN 50 PN 40	----	----	----	----	19.69	20.47	23.62	24.41	----	----	----	----	----
	05D5	DN 50 PN 63	----	----	----	----	20.47	----	24.41	----	----	----	----	----	----
	05D6	DN 50 PN 100	----	----	----	----	23.23	----	25.98	----	----	----	----	----	----
	05D7	DN 50 PN 160	----	----	----	----	23.23	----	25.98	----	----	----	----	----	----
	08D4	DN 80 PN 40	----	----	----	----	----	----	24.02	24.41	39.37	40.16	----	----	----
	08D5	DN 80 PN 63	----	----	----	----	----	----	24.41	----	39.37	----	----	----	----
	08D6	DN 80 PN 100	----	----	----	----	----	----	28.74	----	39.37	----	----	----	----
	10D2	DN 100 PN 16	----	----	----	----	----	----	----	----	39.37	----	43.31	----	----
	10D4	DN 100 PN 40	----	----	----	----	----	----	----	----	39.37	40.16	43.31	----	----
	10D5	DN 100 PN 63	----	----	----	----	----	----	----	----	39.37	----	43.31	----	----
	10D6	DN 100 PN 100	----	----	----	----	----	----	----	----	41.34	----	43.31	----	----
	12D2	DN 125 PN 16	----	----	----	----	----	----	----	----	39.37	40.16	43.31	43.31	----
	12D4	DN 125 PN 40	----	----	----	----	----	----	----	----	39.37	40.16	43.31	43.31	----
	12D5	DN 125 PN 63	----	----	----	----	----	----	----	----	39.37	----	43.31	43.31	----
	12D6	DN 125 PN 100	----	----	----	----	----	----	----	----	43.31	----	44.88	43.31	----
	12D7	DN 125 PN 160	----	----	----	----	----	----	----	----	----	----	43.31	----	----
	15D2	DN 150 PN 16	----	----	----	----	----	----	----	----	----	----	43.31	43.31	53.15
	15D4	DN 150 PN 40	----	----	----	----	----	----	----	----	----	----	43.31	43.31	53.15
15D5	DN 150 PN 63	----	----	----	----	----	----	----	----	----	----	44.88	----	53.15	
15D6	DN 150 PN 100	----	----	----	----	----	----	----	----	----	----	46.46	----	----	
20D2	DN 200 PN 16	----	----	----	----	----	----	----	----	----	----	----	----	53.15	
20D4	DN 200 PN 40	----	----	----	----	----	----	----	----	----	----	----	----	53.15	
20D5	DN 200 PN 63	----	----	----	----	----	----	----	----	----	----	----	----	53.15	

Table 11 : Selection Table Process Connection and Materials, Installation Length in inch (continued)

			RCCS	RCCS	RCCS34		RCCS36		RCCS38		RCCS39		RCCS39		RCCS39	
			30LR	30-33	RCCT34	RCCT36	RCCT38	RCCT39	RCCT39/IR	RCCT39/XR						
			SH	SH	SL	HC	SL	HC	SL	HC	SL	HC	SL	HC	SL	HC
Flanges according to JIS B 2220	01J1	DN 15 10K	9.45	9.45	14.57	----	----	----	----	----	----	----	----	----	----	----
	01J2	DN 15 20K	9.45	9.45	14.57	----	----	----	----	----	----	----	----	----	----	----
	02J1	DN 25 10K	----	9.45	14.57	15.35	19.69	----	----	----	----	----	----	----	----	----
	02J2	DN 25 20K	----	9.45	14.57	15.35	19.69	----	----	----	----	----	----	----	----	----
	04J1	DN 40 10K	----	9.45	14.57	15.35	19.69	20.47	23.62	----	----	----	----	----	----	----
	04J2	DN 40 20K	----	9.45	14.57	15.35	19.69	20.47	23.62	----	----	----	----	----	----	----
	05J1	DN 50 10K	----	----	----	----	19.69	20.47	23.62	24.41	----	----	----	----	----	----
	05J2	DN 50 20K	----	----	----	----	19.69	20.47	23.62	24.41	----	----	----	----	----	----
	08J1	DN 80 10K	----	----	----	----	----	----	23.62	24.41	39.37	40.16	----	----	----	----
	08J2	DN 80 20K	----	----	----	----	----	----	24.02	24.41	39.37	40.16	----	----	----	----
	10J1	DN 100 10K	----	----	----	----	----	----	----	----	39.37	40.16	43.31	----	----	----
	10J2	DN 100 20K	----	----	----	----	----	----	----	----	39.37	40.16	43.31	----	----	----
	12J1	DN 125 10K	----	----	----	----	----	----	----	----	39.37	40.16	43.31	43.31	----	----
	12J2	DN 125 20K	----	----	----	----	----	----	----	----	39.37	40.16	43.31	43.31	----	----
	15J1	DN 150 10K	----	----	----	----	----	----	----	----	----	----	43.31	43.31	----	----
15J2	DN 150 20K	----	----	----	----	----	----	----	----	----	----	43.31	43.31	----	----	
Clamp DIN	01S4	DN 15	9.45	9.45	----	----	----	----	----	----	----	----	----	----	----	----
	02S4	DN 25	----	9.45	14.57	----	----	----	----	----	----	----	----	----	----	----
	04S4	DN 40	----	9.45	14.57	----	19.69	----	----	----	----	----	----	----	----	----
	05S4	DN 50	----	----	----	----	19.69	----	23.62	----	----	----	----	----	----	----
	06S4	DN 65	----	----	----	----	----	----	23.62	----	----	----	----	----	----	----
	10S4	DN 100	----	----	----	----	----	----	----	----	39.37	----	----	----	----	----
Tri-Clamp	01S8	½"	9.45	9.45	----	----	----	----	----	----	----	----	----	----	----	----
	02S8	1"	----	9.45	14.57	----	----	----	----	----	----	----	----	----	----	----
	04S8	1½"	----	9.45	14.57	----	19.69	----	----	----	----	----	----	----	----	----
	05S8	2"	----	----	----	----	19.69	----	23.62	----	----	----	----	----	----	----
	08S8	3"	----	----	----	----	----	----	23.62	----	----	----	----	----	----	----
	10S8	4"	----	----	----	----	----	----	----	----	39.37	----	----	----	----	----
DIN11851	02S2	DN 25	----	9.45	14.57	----	----	----	----	----	----	----	----	----	----	----
	04S2	DN 40	----	----	----	----	19.69	----	----	----	----	----	----	----	----	----
	05S2	DN 50	----	----	----	----	----	----	23.62	----	----	----	----	----	----	----
	10S2	DN 100	----	----	----	----	----	----	----	----	39.37	----	----	----	----	----
Thread	41G9	G¼" female	10.24	10.24	----	----	----	----	----	----	----	----	----	----	----	----
	01G9	G½" female	10.24	10.24	15.35	----	----	----	----	----	----	----	----	----	----	----
	23G9	G¾" female	10.24	10.24	15.35	----	----	----	----	----	----	----	----	----	----	----
	41T9	NPT¼" female	10.24	10.24	----	----	----	----	----	----	----	----	----	----	----	----
	01T9	NPT½" female	10.24	10.24	15.35	----	----	----	----	----	----	----	----	----	----	----
	23T9	NPT¾" female	10.24	10.24	15.35	----	----	----	----	----	----	----	----	----	----	----

Table 12 : CRN approved process connections

		RCCS 30 - 32	RCCS34 RCCT34		RCCS36 RCCT36		RCCS38 RCCT38		RCCS39 RCCT39		RCCS39/IR RCCT39/IR		RCCS39/XR RCCT39/XR
		SH	SL	HC	SL	HC	SL	HC	SL	HC	SL	HC	SL
Flanges according to ASME B16.5	01A1	1/2"-150	X	X	----	----	----	----	----	----	----	----	----
	01A2	1/2"-300	X	X	----	----	----	----	----	----	----	----	----
	01A3	1/2"-600	X	X	----	----	----	----	----	----	----	----	----
	01A5	1/2"-900/1500	X	X	----	----	----	----	----	----	----	----	----
	02A1	1"-150	X	X	X	X	----	----	----	----	----	----	----
	02A2	1"-300	X	X	X	X	----	----	----	----	----	----	----
	02A3	1"-600	X	X	----	X	----	----	----	----	----	----	----
	02A5	1"-900/1500	X	X	----	X	----	----	----	----	----	----	----
	04A1	1 1/2"-150	X	X	X	----	X	X	----	----	----	----	----
	04A2	1 1/2"-300	X	X	X	X	X	X	----	----	----	----	----
	04A3	1 1/2"-600	X	X	----	X	----	X	----	----	----	----	----
	04A4	1 1/2"-900	----	----	----	----	----	X	----	----	----	----	----
	04A5	1 1/2"-900/1500	X	X	----	X	----	----	----	----	----	----	----
	05A1	2"-150	----	----	----	X	X	X	X	----	----	----	----
	05A2	2"-300	----	----	----	X	X	X	X	----	----	----	----
	05A3	2"-600	----	----	----	X	----	X	----	----	----	----	----
	05A4	2"-900	----	----	----	----	----	X	----	----	----	----	----
	05A5	2"-900/1500	----	----	----	X	----	----	----	----	----	----	----
	06A1	2 1/2"-150	----	----	----	----	----	X	X	----	----	----	----
	06A2	2 1/2"-300	----	----	----	----	----	X	X	----	----	----	----
	06A3	2 1/2"-600	----	----	----	----	----	X	----	----	----	----	----
	06A4	2 1/2"-900	----	----	----	----	----	X	----	----	----	----	----
	08A1	3"-150	----	----	----	----	----	X	X	X	X	----	----
	08A2	3"-300	----	----	----	----	----	X	X	X	X	----	----
	08A3	3"-600	----	----	----	----	----	X	----	X	----	----	----
	08A4	3"-900	----	----	----	----	----	X	----	----	----	----	----
	10A1	4"-150	----	----	----	----	----	----	----	X	X	X	X
	10A2	4"-300	----	----	----	----	----	----	----	X	X	X	X
	10A3	4"-600	----	----	----	----	----	----	----	X	----	X	----
	12A1	5"-150	----	----	----	----	----	----	----	X	X	X	X
	12A2	5"-300	----	----	----	----	----	----	----	X	X	X	X
	12A3	5"-600	----	----	----	----	----	----	----	X	----	X	----
15A1	6"-150	----	----	----	----	----	----	----	----	----	X	X	
15A2	6"-300	----	----	----	----	----	----	----	----	----	X	X	
15A3	6"-600	----	----	----	----	----	----	----	----	----	X	----	
20A1	8"-150	----	----	----	----	----	----	----	----	----	----	X	
20A2	8"-300	----	----	----	----	----	----	----	----	----	----	X	

REGISTERED TRADEMARKS

HART®	: Registered trademark of HART Communication Foundation, Austin, TX, USA
MODBUS®	: Registered trademark of MODBUS Organization
FOUNDATION™ Fieldbus	: Registered trademark of the Fieldbus FOUNDATION, Austin, TX, USA
TRI-CLAMP®	: Registered trademark of Ladish & Co., Inc., Kenosha, USA
FieldMate™	: Registered trademark of Yokogawa Electric Corporation

**YOKOGAWA ELECTRIC CORPORATION****Headquarters**

2-9-32, Nakacho, Musashino-shi, Tokyo, 180-8750 JAPAN
Phone : 81-422-52-5555

Branch Sales Offices

Osaka, Nagoya, Hiroshima, Kurashiki, Fukuoka, Kitakyusyu

YOKOGAWA CORPORATION OF AMERICA**Head Office**

12530 West Airport Blvd, Sugar Land, Texas 77478, USA
Phone : 1-281-340-3800 Fax : 1-281-340-3838

Georgia Office

2 Dart Road, Newnan, Georgia 30265, USA
Phone : 1-800-888-6400/ 1-770-253-7000 Fax : 1-770-254-0928

YOKOGAWA AMERICA DO SUL LTDA.

Praca Acapulco, 31 - Santo Amaro, São Paulo/SP, BRAZIL, CEP-04675-190
Phone : 55-11-5681-2400 Fax : 55-11-5681-4434

YOKOGAWA EUROPE B. V.

Euroweg 2, 3825 HD Amersfoort, THE NETHERLANDS
Phone : 31-88-4641000 Fax : 31-88-4641111

YOKOGAWA ELECTRIC CIS LTD.

Grokholskiy per 13 Building 2, 4th Floor 129090, Moscow, RUSSIA
Phone : 7-495-737-7868 Fax : 7-495-737-7869

YOKOGAWA CHINA CO., LTD.

3F Tower D Cartelo Crocodile Building, No.568 West Tianshan Road,
Shanghai 200335, CHINA
Phone : 86-21-62396262 Fax : 86-21-62387866

YOKOGAWA ELECTRIC KOREA CO., LTD.

(Yokogawa B/D, Yangpyeong-dong 4-Ga), 21, Seonyu-ro 45-gil, Yeongdeungpo-gu,
Seoul, 150-866, KOREA
Phone : 82-2-2628-6000 Fax : 82-2-2628-6400

YOKOGAWA ENGINEERING ASIA PTE. LTD.

5 Bedok South Road, Singapore 469270, SINGAPORE
Phone : 65-6241-9933 Fax : 65-6241-2606

YOKOGAWA INDIA LTD.

Plot No.96, Electronic City Complex, Hosur Road, Bangalore - 560 100, INDIA
Phone : 91-80-4158-6000 Fax : 91-80-2852-1442

YOKOGAWA AUSTRALIA PTY. LTD.

Tower A, 112-118 Talavera Road, Macquarie Park NSW 2113, AUSTRALIA
Phone : 61-2-8870-1100 Fax : 61-2-8870-1111

YOKOGAWA MIDDLE EAST & AFRICA B.S.C.(C)

P.O. Box 10070, Manama, Building 577, Road 2516, Busaiteen 225, Muharraq,
Kingdom of BAHRAIN
Phone : 973-17358100 Fax : 973-17336100

Apr. '15