



Zertifiziertes  
QM-System  
DIN EN ISO 9001  
Zertifikat-Nr. 01017

# Viscosity-Compensated Flow Meters and Switches

for viscous liquids



measuring  
•  
monitoring  
•  
analysing

VKG



- Measuring range:  
Oil 0.1 - 0.45 ... 5 - 80 l/min
- Basic accuracy:  
± 4 % of full scale
- $p_{max}$ : 12 bar;  $t_{max}$ : 100 °C
- Viscosity range:  
1 ... 540 mm<sup>2</sup>/s
- Connection:  
G 1/4 ... G 1 female  
1/4 ... 1" NPT female
- Material:  
brass, stainless steel

S2



KOBOLD companies worldwide:

AUSTRALIA, AUSTRIA, BELGIUM, BULGARIA, CANADA, CHINA, CZECHIA, FRANCE, GERMANY, GREAT BRITAIN, HUNGARY, INDIA, INDONESIA, ITALY, MALAYSIA, MEXICO, NETHERLANDS, PERU, POLAND, REPUBLIC OF KOREA, SPAIN, SWITZERLAND, THAILAND, TUNISIA, TURKEY, USA, VIETNAM

KOBOLD Messring GmbH  
Nordring 22-24  
D-65719 Hofheim/Ts.  
Head Office:  
+49(0)6192 299-0  
+49(0)6192 23398  
info.de@kobold.com  
www.kobold.com



### Description

The KOBOLD flow meters and switches model VKG have a spring-loaded float, which slides within a cylindrical measuring tube and has an integral orifice which is believed to be unique.

This and other design features means that it has for the first time become possible to create a flow meter and switch which fully compensates for viscosity and to a large extent for density even with very low flows. The float of these patented devices contain permanent magnets which actuate a potential free bistable reed contact mounted outside the flow thus ensuring hermetic separation between the medium and the electrical contact system. The contact is embedded within a height-adjustable plastic housing to prevent damage to the contacts by mechanical action or aggressive atmospheres.

### Viscosity Compensation

If the viscosity changes from 1 mm<sup>2</sup>/s to 540 mm<sup>2</sup>/s the indicated value is still accurate within ±5%, even with very low flows, for example, 0.1 l/min.

Comparable devices, for instance conventional float-type flow meters, are, if the viscosity changes to such an extent, subject to indicating errors up to 2500%, especially with comparable low flows. Other instruments with spring-loaded floats, which are allegedly viscosity compensated, still produce indicating errors of more than 500% with the same change in viscosity and a flow of 0.1 l/min.

Thanks to the virtually perfect viscosity compensation and good density compensation the flow meters and switches of the latest generation are suitable both for water and highly viscous oil, without having to change the scale and without readjustment. This constitutes an extremely important advance especially in the critical area of oil lubrication circuits where measurement and switching are necessary at changing media temperatures.

### Applications

- Lubrication circuits
- Paper-making machines
- Machine tools
- Oil lubrication circuits
- Hydraulics
- Extruding plant
- Printing press

### Technical Details

Housing:	aluminium, anodised (not media-contacted)
Screwed fitting:	VKG-x1...: brass, nickel-plated VKG-x2...: stainless steel 1.4301
Float:	VKG-x1...: brass, nickel-plated VKG-x2...: stainless steel 1.4301
Orifice:	stainless steel 1.4310
Spring:	stainless steel 1.4310
Magnet:	oxide ceramic
Measuring glass:	borosilicate glass
Seals:	VKG-x1...: NBR VKG-x2...: FPM
Max. temperature:	+100 °C
Max. pressure:	12 bar
Installation position:	any
Basic accuracy:	±4 % of full scale (for a viscosity of 105 mm <sup>2</sup> /s)
Measuring error with change in viscosity:	for changes in viscosity within 1 ... 540 mm <sup>2</sup> /s the additional deviation is ±5% of full scale maximum
Viscosity range:	1 ... 540 mm <sup>2</sup> /s

### Contacts for VKG-2..., VKG-3..., VKG-4...

Electrical connection:	connector DIN EN 175301-803
Electrical switching values:	N/O contact max. 250V <sub>AC/DC</sub> /1.5 A/100 W/100 VA changeover contact max. 250V <sub>AC/DC</sub> /1 A/30 W/60 VA N/O contact and changeover contact (cCSAus) max. 230V <sub>DC</sub> /0.26 A/60 W, 60V <sub>DC</sub> /1 A/60 W, max. 240V <sub>AC</sub> /0.42 A/100 W, 100V <sub>AC</sub> /1 A/100 W

### Contacts for VKG-2..., VKG-3..., VKG-4... use in hazardous areas



Mechanics:	The apparatus can be used as follows in explosive atmospheres in accordance with the applicable erection regulations on machines, devices and plants, such as e.g. EN 1127-1, EN 60079-14 etc.: a) In Zone 1 (gas hazard, category 2G, EPL Gb) in the explosion groups IIA, IIB and IIC b) In Zone 2 (gas hazard, category 3G, EPL Gc) in the explosion groups IIA, IIB and IIC c) In Zone 21 (dust hazard, category 2D, EPL Db) in the explosion groups IIIA and IIIB
------------	---



d) In Zone 22 (dust hazard, category 3D, EPL Dc) in the explosion groups IIIA and IIIB



ATEX N/O contact  
type 41R57

...G0 and GG:

 II 3 G Ex ic IIC T4 Gc  
 II 3 D Ex ic IIIC T125 °C Dc  
-20 °C ≤ Ta ≤ 80 °C  
max. 250 V<sub>AC/DC</sub>/1,5 A/100 W/100 VA

ATEX changeover contact  
type 41R57U

...H0 and HH:

 II 3 G Ex ic IIC T4 Gc  
 II 3 D Ex ic IIIC T125 °C Dc  
-20 °C ≤ Ta ≤ 80 °C  
max. 250 V<sub>AC/DC</sub>/1 A/30 W/60 VA

Hysteresis: approx. 3.5 mm float movement

Protection: IP 65 (electrical contact)  
IP 54 (side indicator)

Four versions

VKG-1...:  
Flow Meters



VKG-2...:  
Flow Meters and switches with 1 contact



VKG-3...:  
Flow Meters and switches  
with 2 contacts



VKG-4...:  
Flow Meters and switches  
with 1 contact and side indicator for turbid and dark  
media





**Order Details**

Viscosity-compensated flow meters model: VKG-1... (Example: VKG-1103 R15)

Measuring range l/min Oil	Pressure loss Δ P (bar) at rated flow*		Brass	Stainless steel	Contact	Connection female thread		Option special connection
	min.	max.						
0.1...0.45	0.06	0.9	VKG-1101...	VKG-1201...	..00.. = without contact	..R08 = G ¼	..N08 = ¼" NPT	B = outlet female thread, inlet BVB manifold
0.2...1.2	0.04	1.0	VKG-1102...	VKG-1202...		..R08 = G ¼	..N08 = ¼" NPT	
0.4...2	0.04	1.0	VKG-1103...	VKG-1203...		..R15 = G ½	..N15 = ½" NPT	
0.6...3.4	0.04	0.9	VKG-1104...	VKG-1204...		..R15 = G ½	..N15 = ½" NPT	
2...8	0.06	1.0	VKG-1105...	VKG-1205...		..R20 = G ¾	..N20 = ¾" NPT	
3...15	0.04	1.0	VKG-1106...	VKG-1206...		..R20 = G ¾	..N20 = ¾" NPT	
4...20	0.04	1.0	VKG-1107...	VKG-1207...		..R25 = G 1	..N25 = 1" NPT	
2.5...45	0.08	0.4	VKG-1108...	VKG-1208...		..R25 = G 1	..N25 = 1" NPT	
5...55	0.1	1.0	VKG-1109...	VKG-1209...		..R25 = G 1	..N25 = 1" NPT	
2.5...70	0.1	1.1	VKG-1110...	VKG-1210...		..R25 = G 1	..N25 = 1" NPT	
5...80	0.1	1.0	VKG-1111...	VKG-1211...		..R25 = G 1	..N25 = 1" NPT	

\* The pressure loss is based on water

Viscosity-compensated flow meters and switches model: VKG-2... (Example: VKG-2103 R15)

Measuring range l/min Oil	Pressure loss Δ P (bar) at rated flow*		Brass	Stainless steel	Contact	Connection female thread		Option special connection
	min.	max.						
0.1...0.45	0.06	0.9	VKG-2101...	VKG-2201...	..R0.. = 1 N/O contact ..U0.. = 1 changeover contact ..C0.. = 1 N/O contact (cCSAus) ..D0.. = 1 changeover contact (cCSAus) ..G0.. = 1 ATEX N/O contact (model 41R57) ..H0.. = 1 ATEX changeover contact (model 41R57U)	..R08 = G ¼	..N08 = ¼" NPT	B = outlet female thread, inlet BVB manifold
0.2...1.2	0.04	1.0	VKG-2102...	VKG-2202...		..R08 = G ¼	..N08 = ¼" NPT	
0.4...2	0.04	1.0	VKG-2103...	VKG-2203...		..R15 = G ½	..N15 = ½" NPT	
0.6...3.4	0.04	0.9	VKG-2104...	VKG-2204...		..R15 = G ½	..N15 = ½" NPT	
2...8	0.06	1.0	VKG-2105...	VKG-2205...		..R20 = G ¾	..N20 = ¾" NPT	
3...15	0.04	1.0	VKG-2106...	VKG-2206...		..R20 = G ¾	..N20 = ¾" NPT	
4...20	0.04	1.0	VKG-2107...	VKG-2207...		..R25 = G 1	..N25 = 1" NPT	
2.5...45	0.08	0.4	VKG-2108...	VKG-2208...		..R25 = G 1	..N25 = 1" NPT	
5...55	0.1	1.0	VKG-2109...	VKG-2209...		..R25 = G 1	..N25 = 1" NPT	
2.5...70	0.1	1.1	VKG-2110...	VKG-2210...		..R25 = G 1	..N25 = 1" NPT	
5...80	0.1	1.0	VKG-2111...	VKG-2211...		..R25 = G 1	..N25 = 1" NPT	

\* The pressure loss is based on water



**Order Details**

Viscosity-compensated flow meters and switches with 2 contacts model: VKG-3... (Example: VKG-3103 R15)

Measuring range l/min Oil	Pressure loss Δ P (bar) at rated flow*		Brass	Stainless steel	Contact	Connection female thread	
	min.	max.					
0.1...0.45	0.06	0.9	VKG-3101...	VKG-3201...	..RR.. = 2 N/O contacts ..UU.. = 2 changeover contacts ..CC.. = 2 N/O contacts (cCSAus) ..DD.. = 2 changeover contacts (cCSAus) ..GG.. = 2 ATEX N/O contact (model 41R57) ..HH.. = 2 ATEX changeover contact (model 41R57U)	..R08 = G ¼	..N08 = ¼" NPT
0.2...1.2	0.04	1.0	VKG-3102...	VKG-3202...		..R08 = G ¼	..N08 = ¼" NPT
0.4...2	0.04	1.0	VKG-3103...	VKG-3203...		..R15 = G ½	..N15 = ½" NPT
0.6...3.4	0.04	0.9	VKG-3104...	VKG-3204...		..R15 = G ½	..N15 = ½" NPT
2...8	0.06	1.0	VKG-3105...	VKG-3205...		..R20 = G ¾	..N20 = ¾" NPT
3...15	0.04	1.0	VKG-3106...	VKG-3206...		..R25 = G 1	..N25 = 1" NPT
4...20	0.04	1.0	VKG-3107...	VKG-3207...		..R25 = G 1	..N25 = 1" NPT
2.5...45	0.08	0.4	VKG-3108...	VKG-3208...			
5...55	0.1	1.0	VKG-3109...	VKG-3209...			
2.5...70	0.1	1.1	VKG-3110...	VKG-3210...			
5...80	0.1	1.0	VKG-3111...	VKG-3211...			

\* The pressure loss is based on water

Viscosity-compensated flow meters and switches with side indicator model: VKG-4... (Example: VKG-4103 R15)

Measuring range l/min Oil	Pressure loss Δ P (bar) at rated flow*		Brass	Stainless steel	Contact	Connection female thread		Option special connection
	min.	max.						
0.1...0.45	0.06	0.9	VKG-4101...	VKG-4201...	..R0.. = 1 N/O contact ..U0.. = 1 changeover contact ..C0.. = 1 N/O contact (cCSAus) ..D0.. = 1 changeover contact (cCSAus) ..G0.. = 1 ATEX N/O contact (model 41R57) ..H0.. = 1 ATEX changeover contact (model 41R57U)	..R08 = G ¼	..N08 = ¼" NPT	B = outlet female thread, inlet BVB manifold
0.2...1.2	0.04	1.0	VKG-4102...	VKG-4202...		..R08 = G ¼	..N08 = ¼" NPT	
0.4...2	0.04	1.0	VKG-4103...	VKG-4203...		..R15 = G ½	..N15 = ½" NPT	
0.6...3.4	0.04	0.9	VKG-4104...	VKG-4204...		..R15 = G ½	..N15 = ½" NPT	
2...8	0.06	1.0	VKG-4105...	VKG-4205...		..R20 = G ¾	..N20 = ¾" NPT	
3...15	0.04	1.0	VKG-4106...	VKG-4206...		..R25 = G 1	..N25 = 1" NPT	
4...20	0.04	1.0	VKG-4107...	VKG-4207...		..R25 = G 1	..N25 = 1" NPT	
2.5...45	0.08	0.4	VKG-4108...	VKG-4208...				
5...55	0.1	1.0	VKG-4109...	VKG-4209...				
2.5...70	0.1	1.1	VKG-4110...	VKG-4210...				
5...80	0.1	1.0	VKG-4111...	VKG-4211...				

\* The pressure loss is based on water

Dimensions model VKG-1..., VKG-2..., VKG-3...

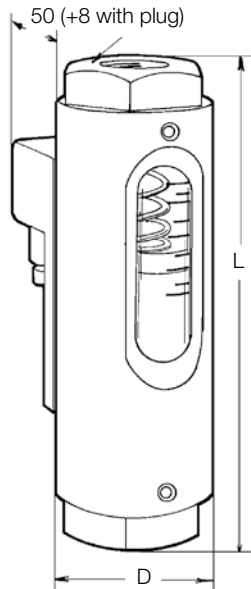

Dimensions model VKG-4..

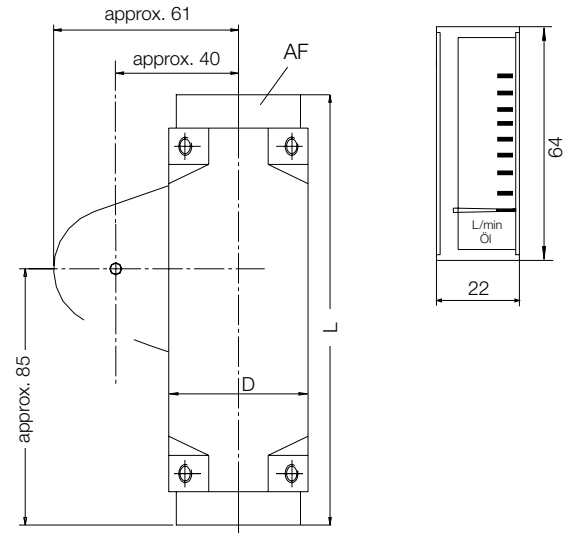

Model	D [mm]	AF [mm]	Weight [kg] (VKG-1..)	
			Standard connection	Special connection
VKG-..01	48	41	0.9	0.9
VKG-..02	48	41	0.9	0.8
VKG-..03	48	41	0.9	0.8
VKG-..04	48	41	0.9	0.8
VKG-..05	48	41	0.9	0.8
VKG-..06	48	41	0.8	0.8
VKG-..07	48	41	0.8	0.8
VKG-..08	48	41	0.8	0.7
VKG-..09	48	41	0.8	0.7
VKG-..10	48	41	0.8	0.7
VKG-..11	48	41	0.7	0.7

Model	D [mm]	AF [mm]	Weight [kg] (VKG-1..)	
			Standard connection	Special connection
VKG-..01	46 x 46	41	1.3	1.3
VKG-..02	46 x 46	41	1.3	1.2
VKG-..03	46 x 46	41	1.3	1.2
VKG-..04	46 x 46	41	1.3	1.2
VKG-..05	46 x 46	41	1.2	1.2
VKG-..06	46 x 46	41	1.2	1.2
VKG-..07	46 x 46	41	1.2	1.1
VKG-..08	46 x 46	41	1.2	1.1
VKG-..09	46 x 46	41	1.2	1.1
VKG-..10	46 x 46	41	1.1	1.1
VKG-..11	46 x 46	41	1.1	1.1

Connection female thread				Option special connection			
Model	L [mm]	Model	L [mm]	Model	L [mm]	Model	L [mm]
VKG-..R08	143	VKG-..N08	143	VKG-..R08 B	148	VKG-..N08 B	148
VKG-..R15	143	VKG-..N15	143	VKG-..R15 B	148	VKG-..N15 B	148
VKG-..R20	153	VKG-..N20	153	VKG-..R20 B	153	VKG-..N20 B	153
VKG-..R25	153	VKG-..N25	153	VKG-..R25 B	153	VKG-..N25 B	153