

Operating Instructions Display and adjustment module for OPTISOUND sensors

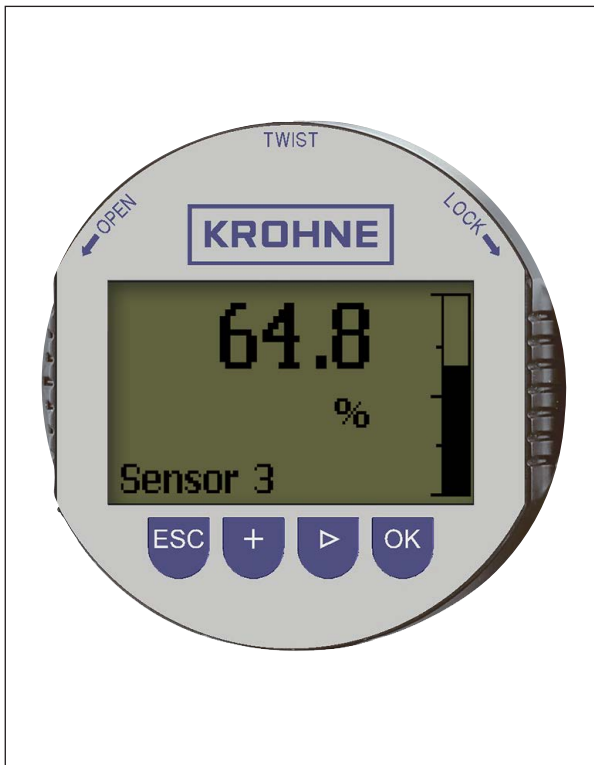

Document
ID: 30603

Variable area flowmeters

Vortex flowmeters

Flow controllers

Electromagnetic flowmeters

Ultrasonic flowmeters

Mass flowmeters

Level measuring instruments

Communications engineering

Engineering systems & solutions

Switches, counters, displays and recorders

Heat metering

Pressure and temperature

Contents

1 About this document	
1.1 Function	3
1.2 Target group	3
1.3 Symbols used.....	3
2 For your safety	
2.1 Authorised personnel	4
2.2 Appropriate use.....	4
2.3 Warning about incorrect use.....	4
2.4 General safety instructions	4
2.5 CE conformity.....	4
2.6 NAMUR recommendations	4
2.7 Safety instructions for Ex areas	5
3 Product description	
3.1 Configuration.....	6
3.2 Principle of operation.....	6
3.3 Operation	6
3.4 Packaging, transport and storage.....	6
4 Mounting	
4.1 Installation procedure	8
5 Setup	
5.1 Adjustment system	9
5.2 General functions	9
5.3 Functions - 4 ... 20 mA/HART	15
5.4 Menu plan ultrasonic sensor	17
6 Maintenance and fault rectification	
6.1 Maintenance	20
6.2 Instrument repair	20
7 Dismount	
7.1 Dismounting steps.....	21
7.2 Disposal	21
8 Supplement	
8.1 Technical data	22
8.2 Dimensions	22

Safety instructions for Ex areas



Take note of the Ex specific safety instructions for Ex applications. These instructions are attached as documents to each instrument with Ex approval and are part of the operating instructions manual.

Editing status: 2014-11-24

1 About this document

1.1 Function

This operating instructions manual has all the information you need for quick setup and safe operation of the display and adjustment module. Please read this manual before you start setup.

1.2 Target group

This operating instructions manual is directed to trained specialist personnel. The contents of this manual should be made available to these personnel and put into practice by them.

1.3 Symbols used



Information, tip, note

This symbol indicates helpful additional information.



Caution: If this warning is ignored, faults or malfunctions can result.



Warning: If this warning is ignored, injury to persons and/or serious damage to the instrument can result.



Danger: If this warning is ignored, serious injury to persons and/or destruction of the instrument can result.



Ex applications

This symbol indicates special instructions for Ex applications.



SIL applications

This symbol indicates instructions for functional safety which must be taken into account particularly for safety-relevant applications.



List

The dot set in front indicates a list with no implied sequence.



Action

This arrow indicates a single action.



Sequence of actions

Numbers set in front indicate successive steps in a procedure.

2 For your safety

2.1 Authorised personnel

All operations described in this operating instructions manual must be carried out only by trained specialist personnel authorised by the plant operator.

During work on and with the device the required personal protective equipment must always be worn.

2.2 Appropriate use

The display and adjustment module is a pluggable unit for OPTISOUND level sensors.

2.3 Warning about incorrect use

Inappropriate or incorrect use of the instrument can give rise to application-specific hazards, e.g. vessel overflow or damage to system components through incorrect mounting or adjustment.

2.4 General safety instructions

This is a state-of-the-art instrument complying with all prevailing regulations and guidelines. The instrument must only be operated in a technically flawless and reliable condition. The operator is responsible for the trouble-free operation of the instrument.

During the entire duration of use, the user is obliged to determine the compliance of the necessary occupational safety measures with the current valid rules and regulations and also take note of new regulations.

The safety instructions in this operating instructions manual, the national installation standards as well as the valid safety regulations and accident prevention rules must be observed by the user.

For safety and warranty reasons, any invasive work on the device beyond that described in the operating instructions manual may be carried out only by personnel authorised by the manufacturer. Arbitrary conversions or modifications are explicitly forbidden.

The safety approval markings and safety tips on the device must also be observed.

2.5 CE conformity

The device fulfills the legal requirements of the applicable EC guidelines. By affixing the CE marking, we confirm successful testing of the product.

2.6 NAMUR recommendations

NAMUR is the automation technology user association in the process industry in Germany. The published NAMUR recommendations are accepted as the standard in field instrumentation.

The device fulfills the requirements of the following NAMUR recommendations:

- NE 21 – Electromagnetic compatibility of equipment

For further information see www.namur.de.

2.7 Safety instructions for Ex areas

Please note the Ex-specific safety information for installation and operation in Ex areas. These safety instructions are part of the operating instructions manual and come with the Ex-approved instruments.

3 Product description

3.1 Configuration

Scope of delivery

The scope of delivery encompasses:

- Display and adjustment module
- Documentation
 - this operating instructions manual

Equipment

The indicating/adjustment module consists of a display with full dot matrix as well as four keys for adjustment.

An LED background lighting is integrated in the display and can be switched on via the adjustment menu.

3.2 Principle of operation

Area of application

The display and adjustment module is used for measured value indication, adjustment, and diagnostics for the following OPTISOUND sensors:

- OPTISOUND 3010 C
- OPTISOUND 3020 C
- OPTISOUND 3030 C
- OPTISOUND 3040 C
- OPTISOUND 3050 C

The display and adjustment module is integrated into the respective sensor housing. After installation, sensor as well as module without housing cover are splash-proof.

Voltage supply

Power is supplied directly by the respective sensor. An additional connection is not necessary.

3.3 Operation

The adjustment is carried out via the integrated keys. The entered parameters are generally saved in the respective sensor. A copy function enables loading of the parameters into the display and adjustment module.

3.4 Packaging, transport and storage

Packaging

Your instrument was protected by packaging during transport. Its capacity to handle normal loads during transport is assured by a test based on ISO 4180.

The packaging of standard instruments consists of environment-friendly, recyclable cardboard. For special versions, PE foam or PE foil is also used. Dispose of the packaging material via specialised recycling companies.

Transport

Transport must be carried out in due consideration of the notes on the transport packaging. Nonobservance of these instructions can cause damage to the device.

Transport inspection	The delivery must be checked for completeness and possible transit damage immediately at receipt. Ascertained transit damage or concealed defects must be appropriately dealt with.
Storage	<p>Up to the time of installation, the packages must be left closed and stored according to the orientation and storage markings on the outside.</p> <p>Unless otherwise indicated, the packages must be stored only under the following conditions:</p> <ul style="list-style-type: none">● Not in the open● Dry and dust free● Not exposed to corrosive media● Protected against solar radiation● Avoiding mechanical shock and vibration
Storage and transport temperature	<ul style="list-style-type: none">● Storage and transport temperature see chapter "<i>Supplement - Technical data - Ambient conditions</i>"● Relative humidity 20 ... 85 %

4 Mounting

Mount/Dismount display and adjustment module

4.1 Installation procedure

The display and adjustment module can be inserted or removed at any time. It is not necessary to interrupt the voltage supply.

Proceed as follows for mounting the display and adjustment module:

1. Unscrew the housing cover
2. Place the display and adjustment module in the desired position on the electronics (you can choose any one of four different positions - each displaced by 90°)



Fig. 1: Insert display and adjustment module

3. Press the display/adjustment module lightly onto the electronics and turn it to the right until it snaps in
4. Screw housing cover with inspection window tightly back on



Note:

If you intend to retrofit the instrument with a display and adjustment module for continuous measured value indication, a higher cover with an inspection glass is required.

Dismounting is carried out in reverse order.

5 Setup

5.1 Adjustment system

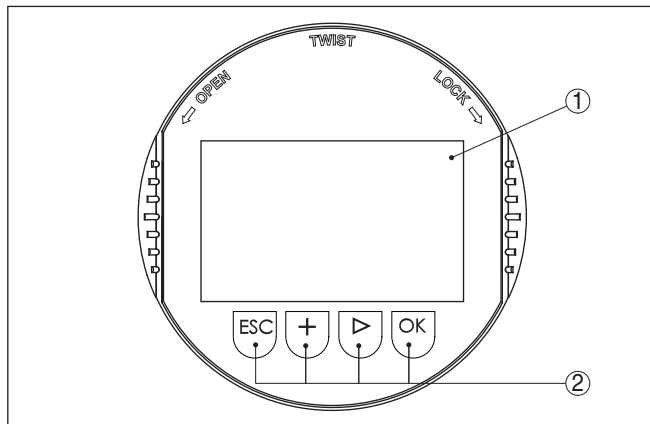

Fig. 2: Display and adjustment elements

- 1 LC display
- 2 Indication of the menu item number
- 3 Adjustment keys

Key functions

- **[OK]** key:
 - Move to the menu overview
 - Confirm selected menu
 - Edit parameter
 - Save value
- **[->]** key to select:
 - Menu change
 - Select list entry
 - Select editing position
- **[+]** key:
 - Change value of the parameter
- **[ESC]** key:
 - Interrupt input
 - Jump to next higher menu

Adjustment system

The sensor is adjusted via the four keys of the display and adjustment module. The LC display indicates the individual menu items. The functions of the individual keys are shown in the above illustration. Approx. 10 minutes after the last pressing of a key, an automatic reset to measured value indication is triggered. Any values not confirmed with **[OK]** will not be saved.

5.2 General functions

OPTISOUND ultrasonic sensors have manifold functions at their disposal. This allows them to be adapted perfectly to the respective

application. These functions are structured in menu form. Some of the functions are sensor-specific. These are described in the operating instructions manual of the respective sensor. Other functions, however, have general character, i.e. they are available in sensors that operate according to other measuring principles.

The general functions are described in this paragraph. The functions of the display/adjustment module are determined by the sensor and correspond to the respective software version of the sensor.



Information:

The respective menu item number differs depending on the sensor type and signal output.

Measured value indication

The following presentations are available in the measured value display:

- Level as digital value, sensor TAG
- Level as digital value and bar graph, sensor TAG

With **[>]** you select different presentations of the measured value. From each of these presentations, you can reach with **[OK]** the menu overview. With **[ESC]** you move from the menu overview again to the measured value indication.

Menu overview

In the menu overview you select the appropriate menu with **[>]** and open it with **[OK]**. Then the individual menu items are available.

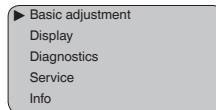

Menu section, basic adjustment

Damping

To damp process-dependent measured value fluctuations, set an integration time of 0 ... 999 s in this menu item.

Depending on the sensor type, the factory setting is 0 s or 1 s.

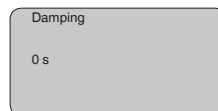

Linearisation curve

In this menu item you select the linearization curve:

- Linear
- Horizontal cylindrical tank
- Spherical tank
- User programmable

User programmable means: Switching on a linearization curve programmed via PC and PACTware

The linearization curve creates a correlation between height and volume. It takes into account the vessel geometry for the displayed measured value and current output.

The default setting is linear.

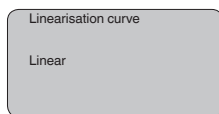

Edit sensor TAG

In the menu item "*Sensor-TAG*" you edit a 12-digit measurement loop name. An unambiguous designation can hence be assigned to the sensor, e.g. the measurement loop name or the tank or product designation. In digital systems and in the documentation of larger plants, a singular designation should be entered for exact identification of individual measuring sites.

The available digits comprise:

- Letters from A ... Z
- Numbers from 0 ... 9
- Special characters +, -, /, -

Factory setting is "*Sensor*".

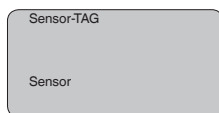

Menu section, diagnostics

Peak value indicator

The respective min. and max. measured values are saved in the sensor. The values are displayed in the menu item "*Peak values*".

- Min. and max. distance in m(d)
- Min. and max. temperature

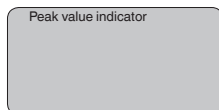

Meas. reliability

When non-contact level sensors are used, the measurement can be influenced by the respective process conditions. In this menu item, the measurement reliability of the level echo is displayed as dB value. The measurement reliability equals signal strength minus noise. The higher the value, the more reliable the measurement. With a functioning measurement, the values are > 10 dB.

Sensor status

The instrument status is displayed in this menu item. If no failure is detected by the sensor, "OK" will be displayed. If a failure is detected, there will be a sensor-specific flashing fault signal, for example "E013". The failure is also displayed in clear text, for example "*No measured value available*".



Information:

The fault message as well as the clear text indication are also carried out in the measured value display.

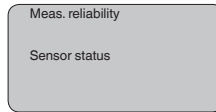

Curve selection

The signal curves enable a first rough evaluation of the measurement. The following curves are available:

- Echo curve
- False echo curve
- Trend curve

The echo curve displays the echoes as signal strength in dB in relation to distance.

The false echo curve displays the saved false echoes (see menu "Service") of the empty vessel as signal strength in "dB" over the measuring range.

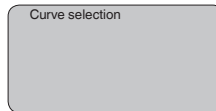

Curve presentation

A comparison of the echo curve and the false echo curve allows a more detailed evaluation of measurement reliability. The selected curve is updated continuously. With the **[OK]** key, a submenu with zoom functions is opened.

The following functions are available with "**Echo and false echo curve**":

- "X-Zoom": Zoom function for the meas. distance
- "Y-Zoom": 1, 2, 5 and 10x signal magnification in "dB"
- "Unzoom": Reset the presentation to the nominal measuring range without magnification

In the menu item "**Trend curve**" the following are available:

- "X-Zoom": Resolution
 - 1 minute
 - 1 hour
 - 1 day
- "Stop/Start": Interrupt a recording or start a new recording
- "Unzoom": Reset the resolution to minutes

As default setting, the recording pattern has 1 minute. With the adjustment software PACTware, this pattern can be also set to 1 hour or 1 day.

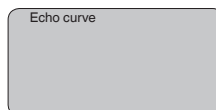

Menu section, service

Simulation of measured values

In this menu item you simulate individual level values via the current output. This allows the signal path to be tested, e.g. via connected indicating instruments or the input card of the processing system.

The following simulation variables are available:

- Percent
- Current
- Distance

How to start the simulation:

1. Push **[OK]**
2. Select the requested simulation variable with **[->]** and confirm with **[OK]**.
3. Set the requested numerical value with **[+]** and **[->]**.
4. Push **[OK]**

The simulation is activated and a corresponding current in the range of 4 ... 20 mA is outputted.

How to interrupt the simulation:

→ Push **[ESC]**



Information:

The simulation is automatically terminated 10 minutes after the last pressing of a key.

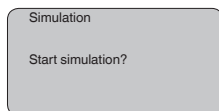

Reset

With the reset function, modified values are reset. Three subfunctions are available:

- Basic adjustment
 - Reset the values modified with the display and adjustment module to the sensor-specific basic setting (see chart)
- Default setting
 - Like basic setting, but also resets special parameters modified with PACTware to delivery status
- Peak values measured value and temperature
 - Reset the min./max. values of level and temperature to the current values

Reset values, basic setting

Menu	Menu item	Ultrasonic
Basic adjustment	Unit of measurement	Deleted
	Min. adjustment	Upper dead zone, depending on instrument
	Max. adjustment	end nominal measuring range
	Linearisation curve	Linear

30603-EN-150102

Menu	Menu item	Ultrasonic
	Sensor-TAG	Sensor
Display	Displayed value 1	Distance
	Scaling	0 % = 0.0, 100 % = 100.0
Service	Current output	Output mode: 4-20 mA
		Failure mode: < 3.6 mA ▼ Min. current: 3.8 mA

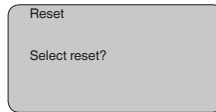

Unit of measurement

In this menu item you select the internal unit of calculation of the sensor: m(d) or ft(d).

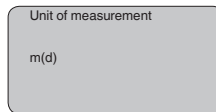

Language

The sensor is already set to the ordered national language. In this menu item you can change the language. The following languages are available:

- Deutsch
- English
- Français
- Español
- Pycckuu

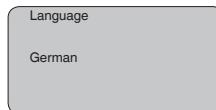

Copy sensor data

With this function

- data are read from the sensor
- Data written into the sensor.

The data are permanently saved in an EEPROM memory in the display/adjustment module and remain there even in case of voltage failure. From there, they can be written into one or several sensors and kept as a backup for a possible sensor exchange. When data is written into the sensor, the instrument type from which the data originate as well as the TAG no. of that sensor are displayed.

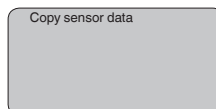

Menu section, info

PIN

In this menu item, the PIN is activated/deactivated permanently. Entering a 4-digit PIN protects the sensor data against unauthorized access and unintentional modifications. If the PIN is activated permanently, it can be deactivated temporarily (i.e. for approx. 60 min.) in any menu item. The instrument is delivered with the PIN set to 0000.

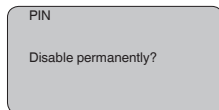

Only the following functions are permitted with activated PIN:

- Select menu items and show data
- Read data from the sensor into the display and adjustment module.

Info

In this menu item the most important sensor information can be displayed:

- Instrument type, e.g. OPTISOUND 3010 C
- Serial number: 8-digit number, e.g. 12345678
- Date of manufacture: Date of the factory calibration
- Software version: Edition of the sensor software
- Date of last change using PC: Date of the last change of sensor parameters via PC
- Sensor details, e.g. approval, process fitting, seal, measuring range, electronics, housing, cable entry, plug, cable length etc.

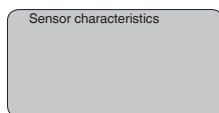
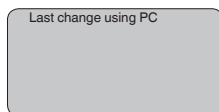
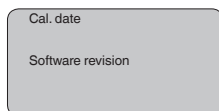
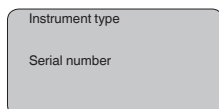

5.3 Functions - 4 ... 20 mA/HART

The 4 ... 20 mA/HART special functions are briefly described in this paragraph. The respective range of functions of the display and ad-

Introduction

justment module is determined by the sensor and the sensor software version.

Display

In the menu item "*Display*" you can define how the measured value should be presented on the display.

The following indication values are available:

- Height
- Distance
- Current
- Scaled
- Percent
- Lin. percent

The selection "*scaled*" opens the menu items "*Display unit*" and "*Scaling*". In "*Display unit*" there are the following options:

- Height
- Ground
- Flow
- Volume
- Without unit

Depending on selection, the different units are in turn available.

In the menu item "*Scaling*", the requested numerical value with decimal point is entered for 0 % and 100 % of the measured value.

There is the following relationship between the indication value in the menu "*Display*" and the adjustment unit in the menu "*Device settings*":

- With ultrasonics, the indication value "*Distance*" means: Presentation of the measured value in the selected adjustment unit, e.g. m(d).

The image shows three sequential screenshots of the device's menu system, each enclosed in a rounded rectangular box:

- Top screenshot:** Titled "Displayed value", it shows the option "Scaled".
- Middle screenshot:** Titled "Display unit", it shows the option "Volume".
- Bottom screenshot:** Titled "Scaling", it shows two options: "0 % = 0.0 l" and "100 % = 100.0 l".

Current output

In the menu item "*Current output*" you determine the behaviour of the current output during operation and in case of failure. The following options are available:

Current output

Characteristics	4 ... 20 mA 20 ... 4 mA
Failure mode ¹⁾	Hold value 20.5 mA 22.0 mA < 3.6 mA
Min. current ²⁾	3.8 mA 4 mA

The values in bold font represent the data of the factory setting.

In HART multidrop mode, the current is constantly 4 mA. This value does not change even in case of failure.

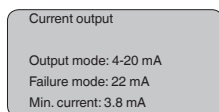

HART mode

HART offers standard and multidrop mode.

The mode standard with the fixed address 0 means output of the measured value as 4 ... 20 mA signal.

In Multidrop mode, up to 15 sensors can be operated on one two-wire cable. An address between 1 and 15 must be assigned to each sensor.³⁾

In this menu item you determine the HART mode and enter the address for multidrop.

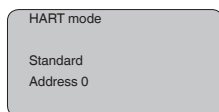

The default setting is standard with address 0.

5.4 Menu plan ultrasonic sensor



Information:

Depending on the version and application, the highlighted menu windows may not always be available.

¹⁾ Value of the current output in case of failure, e.g. if no valid measured value is delivered.

²⁾ This value is not underrun during operation.

³⁾ The 4 ... 20 mA signal of the HART sensor is switched off. The sensor consumes a constant current of 4 mA. The measuring signal is transmitted exclusively as digital HART signal.

Basic adjustment

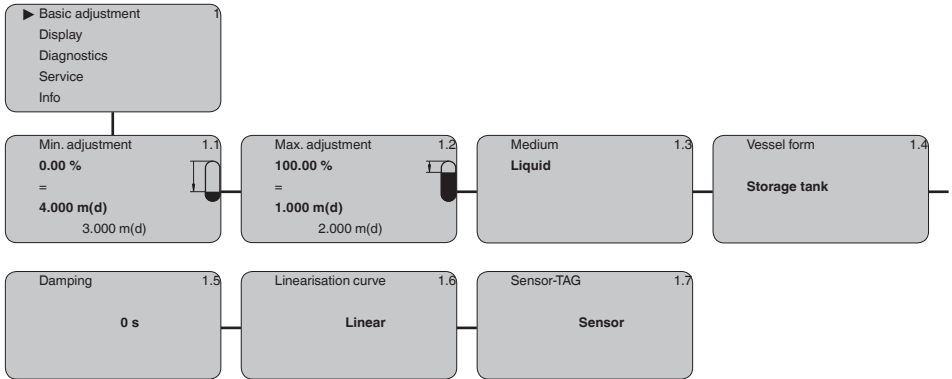

Display

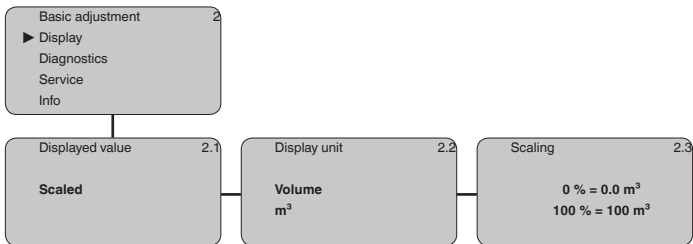

Diagnostics

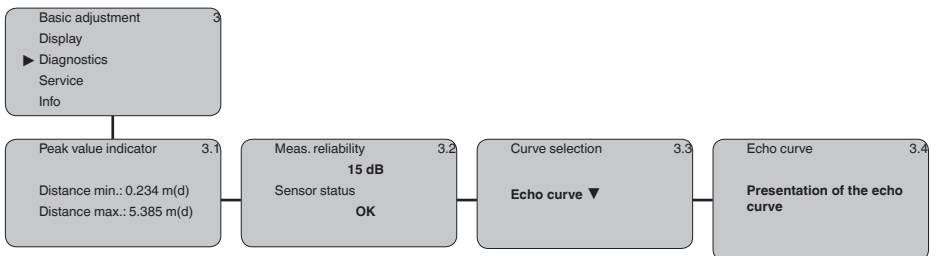

Service

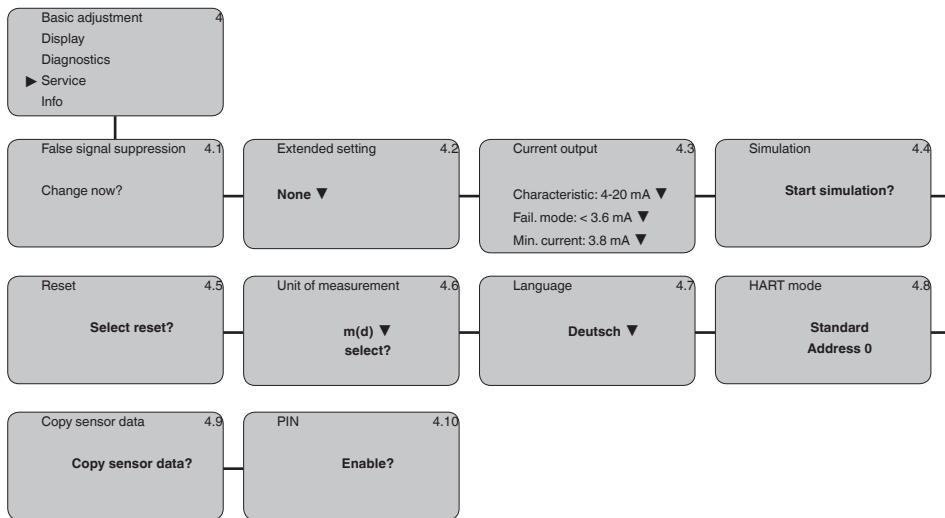

Info

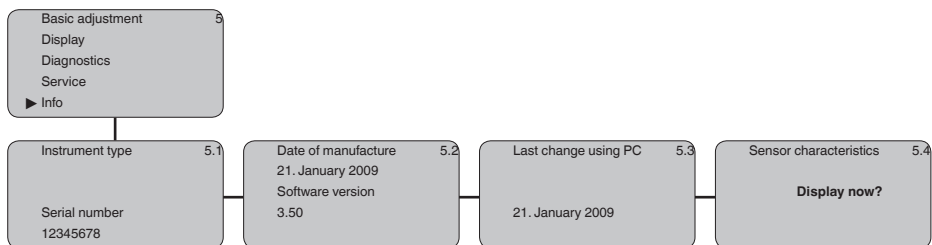

6 Maintenance and fault rectification

6.1 Maintenance

If the instrument is used properly, no special maintenance is required in normal operation.

6.2 Instrument repair

If a repair is necessary, please proceed as follows:

On our homepage in the Internet under

[http://www.krohne-mar.com/fileadmin/
media-lounge/PDF-Download/Specimen_e.pdf](http://www.krohne-mar.com/fileadmin/media-lounge/PDF-Download/Specimen_e.pdf)

you can download a return form.

By doing this you help us carry out the repair quickly and without having to call back for needed information.

- Print and fill out one form per instrument
- Clean the instrument and pack it damage-proof
- Attach the completed form and possibly also a safety data sheet to the instrument

7 Dismount

7.1 Dismounting steps

**Warning:**

Before dismantling, be aware of dangerous process conditions such as e.g. pressure in the vessel or pipeline, high temperatures, corrosive or toxic products etc.

Take note of chapters "*Mounting*" and "*Connecting to power supply*" and carry out the listed steps in reverse order.

7.2 Disposal

The display and adjustment module consists of materials which can be recycled by specialised recycling companies. We have purposely designed the components to be easily separable.

WEEE directive 2002/96/EG

This display and adjustment module is not subject to the WEEE directive 2002/96/EG and the respective national laws (in Germany, e.g. ElektroG). Pass the display and adjustment module directly on to a specialised recycling company and do not use the municipal collecting points. These may only be used for privately used products according to the WEEE directive.

Correct disposal avoids negative effects on humans and the environment and ensures recycling of useful raw materials.

Materials: see chapter "*Technical data*"

If you have no way to dispose of the old instrument properly, please contact us concerning return and disposal.

8 Supplement

8.1 Technical data

General data

Weight approx. 150 g (0.33 lbs)

Ambient conditions

Ambient temperature -15 ... +70 °C (+5 ... +158 °F)

Storage and transport temperature -40 ... +80 °C (-40 ... +176 °F)

Display and adjustment module

Voltage supply and data transmission through the sensor

Indication LC display in dot matrix

Adjustment elements 4 keys

Protection rating

– unassembled IP 20

– mounted into the sensor without cover IP 40

Material

– Housing ABS

– Inspection window Polyester foil

8.2 Dimensions

Display and adjustment module

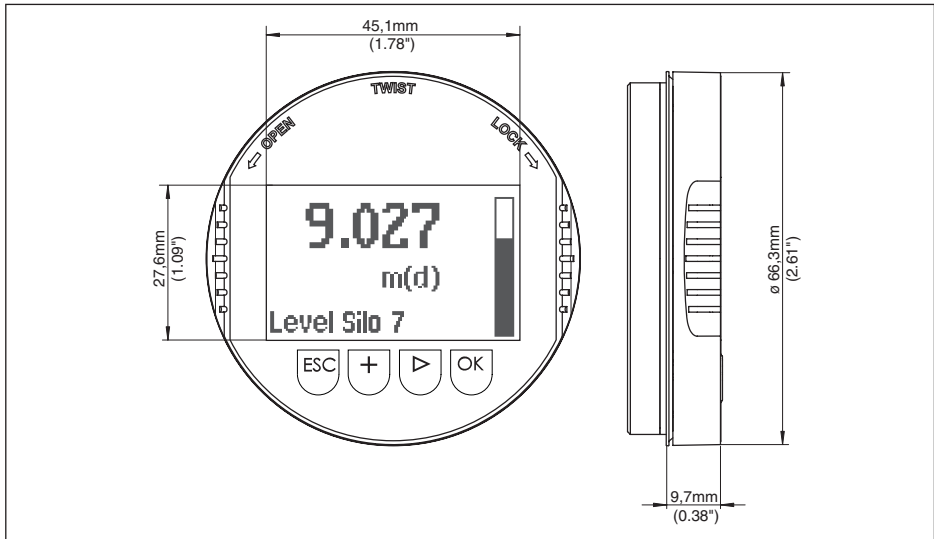
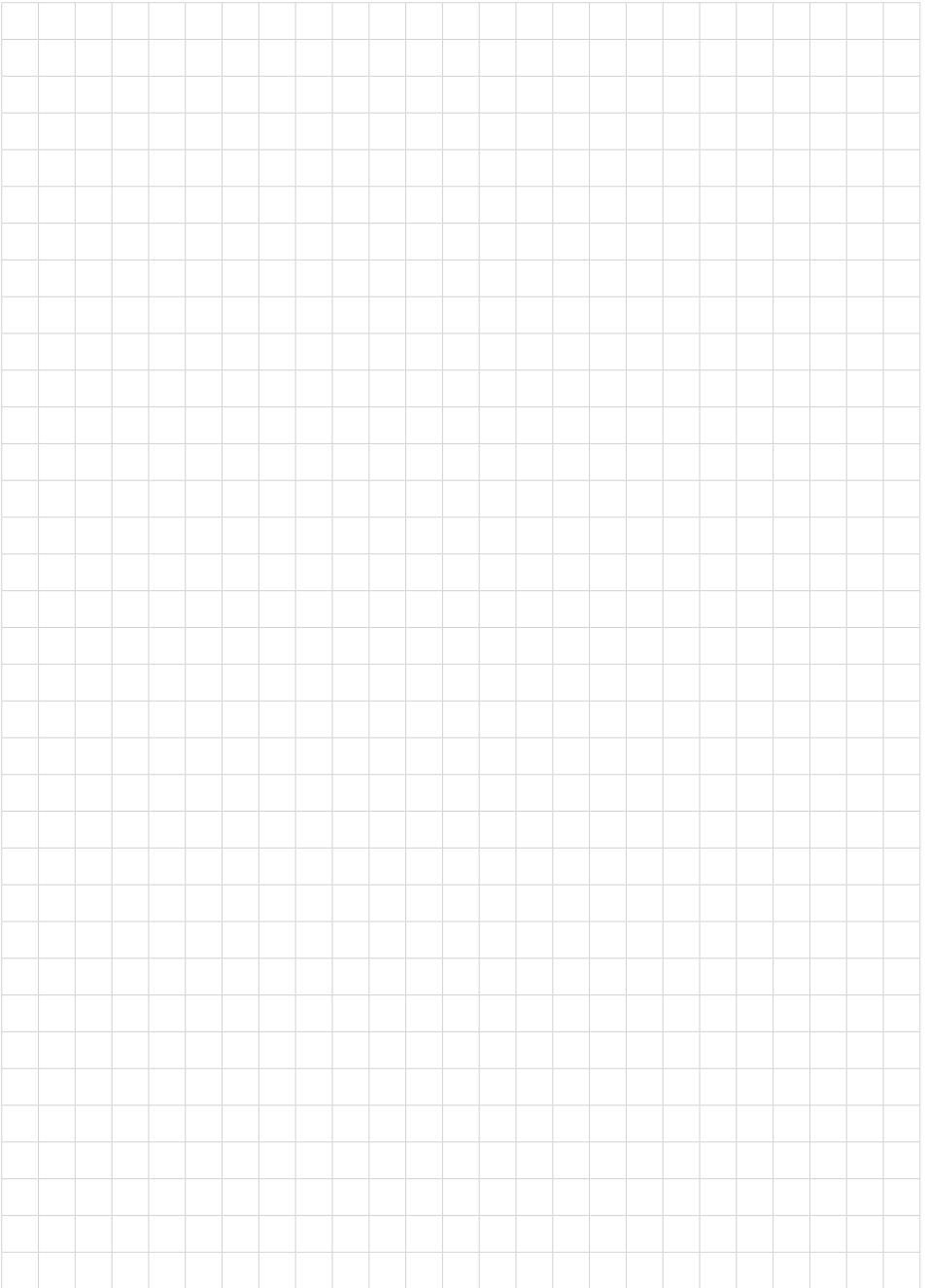

Fig. 3: Display and adjustment module



Subject to change without notice

30603-EN-150102