

SmokeShield PTC™

Proportional Torque Control
Automatic Smoke and Fire Dampers

Features

- Proportional Torque Control for optimised torque performance.
- Unique *snaplock*™ drive interface ensures user friendly connection of Control Mode to Damper.
- Tested and approved to BS ISO 10294-1:1996, BS EN 1366-2:1999 and BS476 pt. 20:1987 Fire Test Standards.
- SmokeShield PTC is an LPCB approved product and conforms to the requirements of LPS1162 issue 4.
- Easy connection to square, rectangular, circular and flat oval ductwork.
- Unique and patented Electrical Thermal Release for ultimate safety.
- Halogen Free Low Smoke and Fume cabling supplied as a standard safety feature.
- Actionpac Damper Control System compatibility.
- VentShield PTC™ reverse action dampers for smoke release or exhaust applications.
- Pneumatic and Electrical ATEX options available.
- ASFP Grey Book Listed.

Dampers Designed and Built in Britain



actionair

Dampers Controls Fancoils

Ruskin Air Management Limited
www.ruskinuk.co.uk

Introduction



Actionair has always been at the forefront in the innovative development, design and manufacture of life safety dampers and associated controls. Now with the unique SmokeShield PTC™ range of Automatic Smoke and Fire Dampers Actionair continues this tradition.

The Range

The SmokeShield PTC™ range of Quality Engineered Dampers are suitable for air conditioning and ventilation systems requiring up to 4 hours protection. Refer to the Actionair Approved Fire and Smoke Dampers Installation Manual for precise details.

These aerodynamic stainless steel interlocking opposed blade dampers are fail-safe spring close with manual or electrical reset control modes.

The VentShield PTC™ Damper range are reverse acting for smoke release or exhaust. (Manual system not available).

Proportional Torque Control

The control mode and *snaplock*™ drive interface provides the optimum mechanical advantage to the damper by delivering:

the right torque, in the right place, at the right time.

Specification

SmokeShield PTC™

Proportional Torque Control Automatic Smoke and Fire Dampers with 75mm x 0.5mm thick stainless steel aerodynamic interlocking blades incorporating synthetic seal, with steel blade end bearings and peripheral gasketing. Housed in a galvanised steel fully welded 1.2mm spigotted casing suitable for square, rectangular, circular or flat oval connections.

All PTC™ Dampers are supplied with blades in the closed position. The totally enclosed precise movement opposed blade drive shall be positioned

out of airstream for protection against damage, be hard wearing and free running.

The Control Mode/Damper connection shall be by means of the *snaplock*™ drive interface mechanism, which is totally independent of the ductwork. SmokeShield PTC™ Automatic Smoke and Fire Dampers with their appropriate control modes shall have spring Fail-Safe Closed operation. SmokeShield PTC™ Damper and selected Control Mode (M1, M5, M6 and M9 with ATEX options) as supplied by Actionair.

SmokeShield PTC™

A Fire Rated Damper in accordance with British Standard BS 9999: 2008 (Ref 33.4.5.3). should be held in the Open Position by means of a Thermally Actuated Device set to operate at approximately 74 °C.

SmokeShield PTC™ Automatic Smoke and Fire Control Dampers are Fire Rated Dampers as they are held in the Reset (Open) Position by a Thermally Actuated Device (Control Mode 1 – Mechanical Fusible Link, Control Modes 5 and 6 – Electrical Thermal Release, Control Mode 9 – Pneumatic Thermal Release) operating at a temperature of approximately 72 °C ± 4 °C.

Note: Thermally activated devices are not supplied with VentShield Control Modes as standard.

VentShield PTC™

Proportional Torque Control Automatic Smoke Release Dampers with 75mm x 0.5mm thick stainless steel aerodynamic blades incorporating synthetic seal, with steel blade end bearings and peripheral gasketing. Housed in a galvanised steel fully welded spigotted casing suitable for square, rectangular, circular or flat oval duct connections.

The totally enclosed precise movement opposed blade drive shall be positioned out of airstream for protection against damage, be hard wearing and free running.

The Control Mode/Damper connection shall be by means of the *snaplock*™ drive interface mechanism, which is totally independent of the ductwork.

VentShield PTC™ Automatic Smoke Release Dampers with their appropriate control modes shall have spring Fail-Safe Open operation.

VentShield PTC™ Damper and selected Control Modes as supplied by Actionair.

Application Parameters

SmokeShield PTC™ and VentShield PTC™ Dampers to maximum width and height dimensions (see pages 16 and 17) can be used where the operating total system pressure is up to 1500 Pascals and duct velocities to 15m/second.

The SmokeShield PTC™ Damper blades are normally open and fail-safe to the closed position. This product is fire rated.

The VentShield PTC™ Damper blades are normally closed and fail-safe to the open

position for smoke release or exhaust. Dampers may be installed both vertically and horizontally. In addition, for vertical installations, the damper may be installed with the blades running vertically. Airflow can be from either direction.

Actionair SmokeShield PTC™ and VentShield PTC™ Dampers are designed for applications in normal dry filtered air systems. If exposed to fresh air intakes and/or inclement conditions, the dampers should be subject to a planned inspection programme.

For specialist and/or aggressive applications, please refer to Actionair Sales Office.

Casing Features

With double skin spigotted galvanised steel (to BS EN 10346:2009) 1.2mm thick casing the SmokeShield PTC™ dampers comply to Class A and B of Eurovent Document 2/2 and Test Procedures for Classes A, B and C of HVCA Ductwork Specification DW144.

Damper casings are manufactured with fully welded spigotted connections suitable for Square, Rectangular, Circular and Flat Oval duct connections.

As an extra cost option, casings can be manufactured in 430 grade (Type 1.4016) Ferritic or 316 grade (Type 1.4401) Austenitic stainless steel, 1.2mm thick.

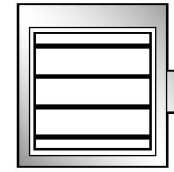
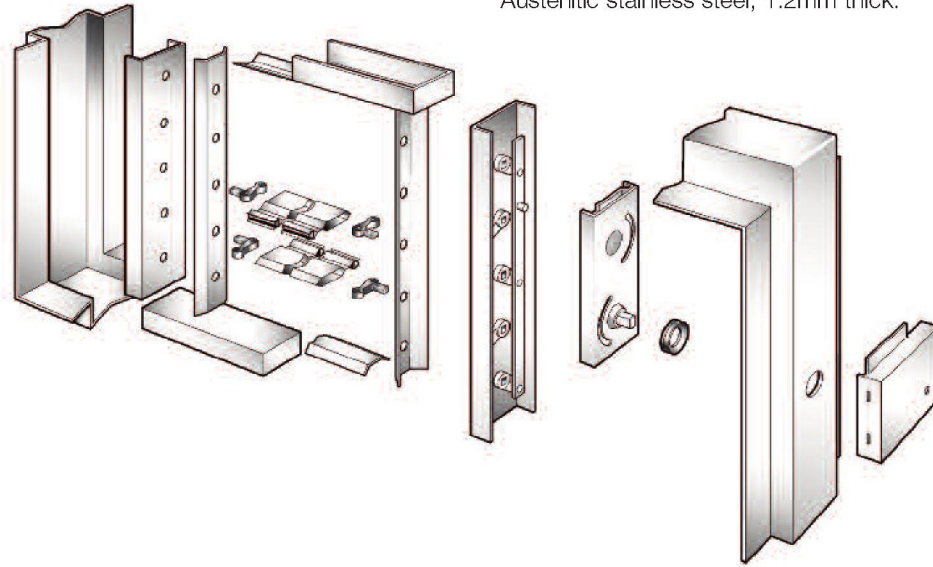

Type SPG Square / Rectangular

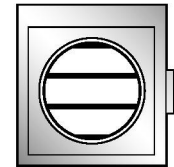

Type SPG Circular

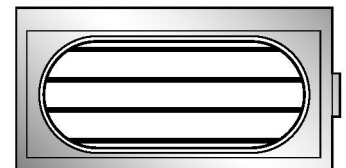

Type SPG Flat Oval

Blade Features

SmokeShield damper blades are aerodynamic double skin, Type 1.4016 (430) Ferritic stainless steel, which are 75mm x 0.5mm thick and interlock to form a positive smoke and fire resisting shield.

Incorporated within the blade profile is a synthetic seal to ensure low closed blade smoke leakage.

Stainless steel blade end bearing and peripheral gasketing maintain the low closed blade smoke leakage whilst allowing for expansion under full fire conditions.

Optional Blade construction Type 1.4401 (316) Austenitic stainless steel.

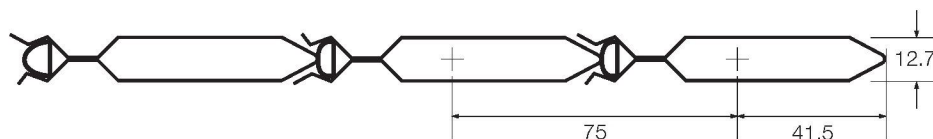

SmokeShield PTC™ blade dimensions

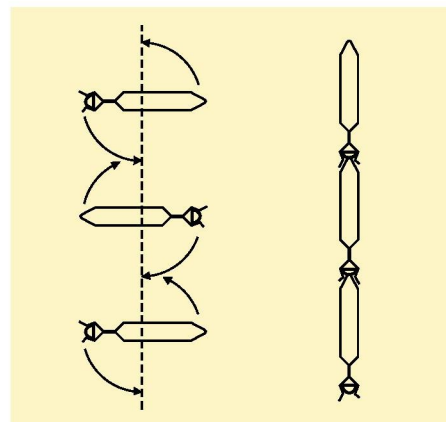

SmokeShield PTC™ fail-safe closed

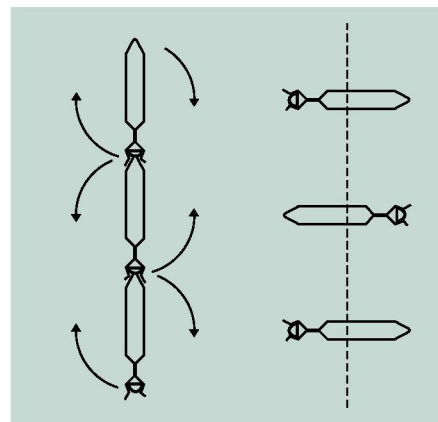

VentShield PTC™ fail-safe open

Multiple Assemblies

Square and rectangular casings are available in multiple module arrangements supplied complete with joining channels for site fixing by others.

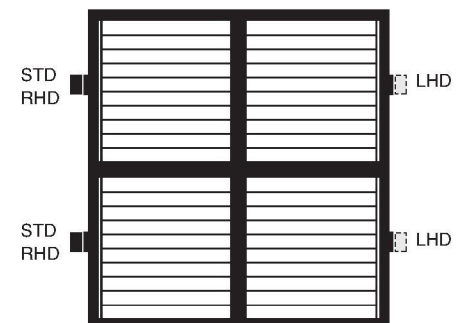

Damper – Control Mode Interface (Right Hand Damper shown)

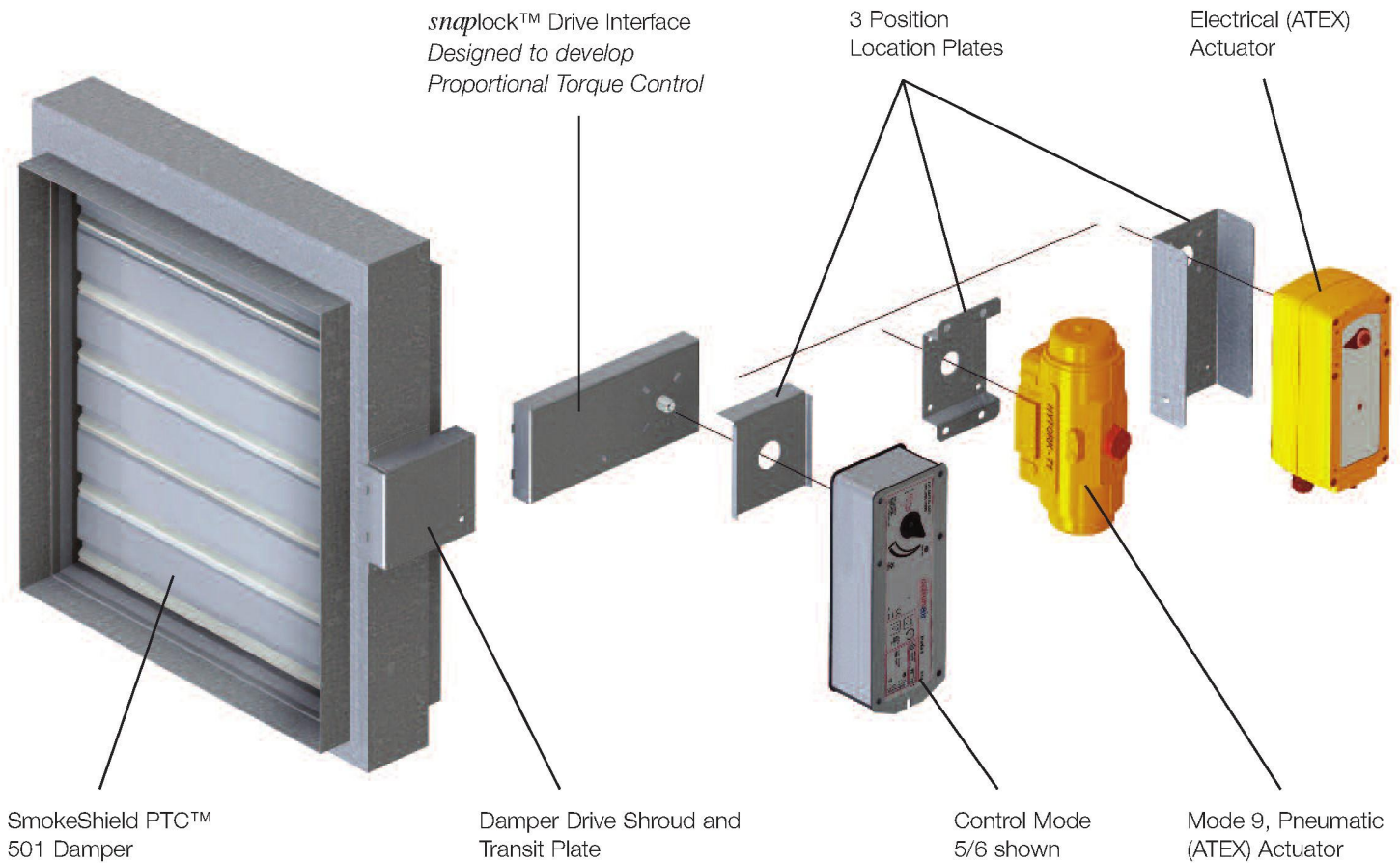

SmokeShield PTC™ Damper with unique *snaplock™* Damper/Control Mode Interface

Automatic Smoke and Fire Damper and Control Mode assembly with a unique and dedicated Proportional Torque Control for optimised Damper/Control Mode torque performance.

The unique *snaplock™* drive interface ensures user friendly, easy and secure connection of the Control Mode to the Damper.

The drive interface which is totally independent of the ductwork, eliminates the need for costly dedicated duct sections, and provides ease of connection to square, rectangular, circular and flat oval ductwork.

This drive interface guarantees that only the correct and certified Actionair products can be used.

Control Options

A choice of Control Modes are located outside of the ductwork for easy access and installation.

All SmokeShield Control Modes must be in the released position prior to connection.

Control Mode 1 Mechanical

Manual reset – with volt free contact for provision of external indication of damper status.

(Not available on Vent Shield).

Control Modes 5 and 6 Electrical

Optimised motor/spring return control modes with remote reset-release facilities, with volt free contacts for provision of external indication, monitoring and control by means of an Actionpac damper control system, or by a suitable alternative proprietary control format.

The motorised Control Modes 5 and 6 can be fitted in 3 positions through 180° (see page 15) allowing maximum on-site installation flexibility. (Position 2 is supplied as standard).

Control Mode 9

Pneumatic

Note: VentShield PTC™ Dampers and associated control modes are reverse action with spring opening (Mode 1 not available).

Thermal Links and Release Types (SmokeShield Only)

Mechanical Fusible Link Control Mode 1

Fail-safe by means of a unique and patented Mechanical Fusible Link which operates at approx. 72 °C, complying with BS 9999 : 2008 (Ref 33.4.5.3).

The link assembly incorporates a safety feature that ensures the fail safe status of the damper if the link is not fitted on to the ductwork.

A manual test may be performed by simple unscrewing the wing nut situated on the fusible link.

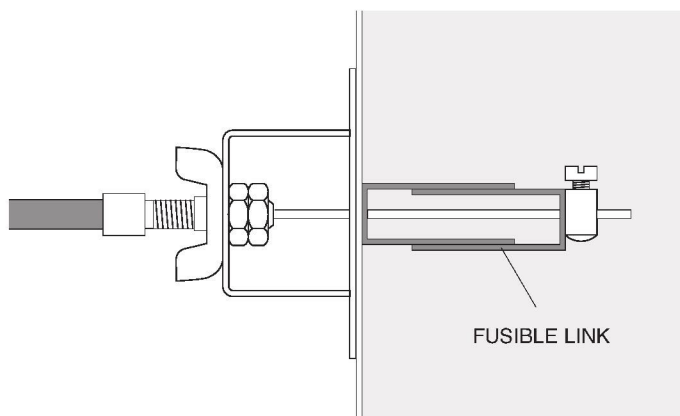

Pneumatic Thermal Release (PTR) Control Mode 9

Fail-safe is by means of a Pneumatic Thermal Release (PTR) which operates at 74°C, or if air supply is interrupted.



Electrical Thermal Release (ETR) Control Modes 5 and 6

Fail-safe by means of a unique and patented electrical thermal release which operates at approx 72 °C or if power supply is interrupted, complying with BS 9999 : 2008 (Ref 33.4.5.3).

The ETR incorporates triple safety features, including an ingenious device that ensures the fail-safe status of the damper if the ETR is not fitted on to the ductwork.

A manual test switch allows periodic operation of the damper for testing purposes simulating actual fail-safe release under smoke/fire conditions.

For safety reasons the ETR/PTR is designed to operate once only when the activation temperature is reached.



ETR Indication light

As standard, a green LED lamp is built into the ETR housing. This gives the user a simple and clear visual check that the Actuator is receiving power, the ETR is correctly fitted, and the thermal fuse is intact.

Control Mode Details

Control Mode 5 PTC and Control Mode 6 PTC

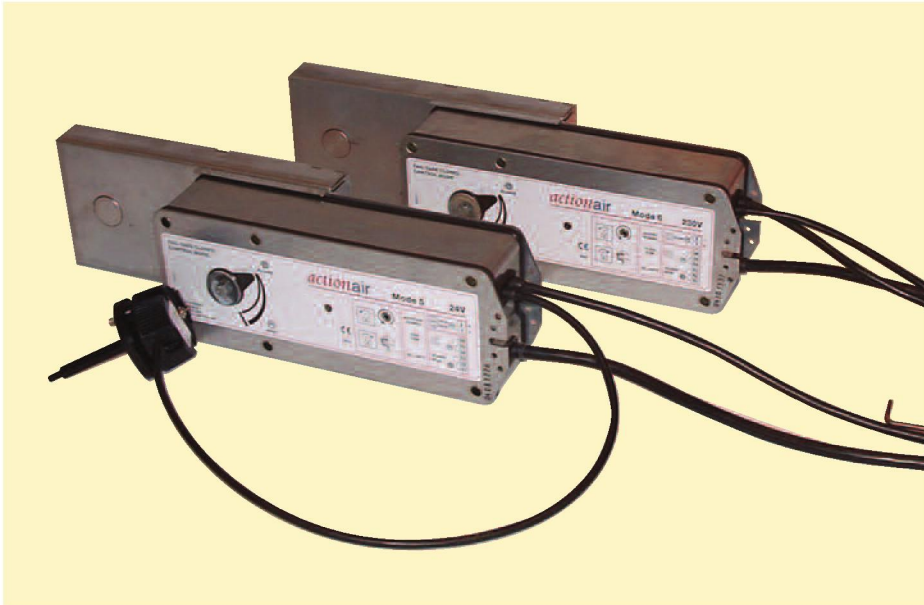

Control Mode 5 PTC and Control Mode 6 PTC 60 seconds MAX Reset/ 22 seconds Release Operation.

This series of control modes achieve 60 seconds to drive to the end position, with a 22 second spring return time.

As with all PTC modes, this series uses the *snaplock™* interface. Fire rated dampers are primarily designed to be fitted into a wall or floor, and the interface displaces the mode from the line of the wall. Dampers may be installed and finally the mode removed from storage for easy fitting, thus preventing damage to the mode before it is required. End switches and LSF cable are provided as standard on these modes.

Versions are available to allow fail-safe close for fire safety (SmokeShield) or fail-safe open for smoke extract (VentShield).

The Electro Thermal Release (ETR) supplied for fire damper use has an integral fail-safe device to ensure that it is installed into the ductwork correctly. ETR units are not supplied with VentShield, because these are designed to fail-safe open.

End switches are provided with each mode, so that damper Reset and Release positions may be monitored. The mode is permanently attached to the mechanism driving the damper blades.

Control Mode 9 PTC



Control Mode 9 PTC

This mode has been developed to provide pneumatic operation of the damper and is available in spring return versions for fail-safe operation. A Pneumatic Thermal Release assembly (PTR) is available (SmokeShield only) to react to fire conditions. As with all PTC actuators, this series uses the *snaplock™* interface. Switch box and solenoid accessories available.

ATEX optional available when fitted with correct Solenoid Valve and Switch Box.

M9 PTC Pneumatic Thermal Release /
Air Off – Fail-safe Close

M9 PTC Vent Pneumatic
Air Off – Fail-safe Open

SmokeShield and VentShield

M5 PTC	10/2W (12.5VA _{MAX})	24V	end switches SPDT 250V 6(3)A	SmokeShield	Thermal Release / Power Off – Fail-safe Close*
M6 PTC	12/4W (14VA _{MAX})	230V	end switches SPDT 250V 6(3)A	SmokeShield	Thermal Release / Power Off – Fail-safe Close*
M5 PTC Vent	10/2W (12.5VA _{MAX})	24V	end switches SPDT 250V 6(3)A	VentShield	Thermal Release / Power Off – Fail-safe Open*
M6 PTC Vent	12/4W (14VA _{MAX})	230V	end switches SPDT 250V 6(3)A	VentShield	Thermal Release / Power Off – Fail-safe Open*
M5 PTC NON ETR	10/2W (12.5VA _{MAX})	24V	end switches SPDT 250V 6(3)A	SmokeShield	Power Off – Fail-safe Close
M6 PTC NON ETR	12/4W (14VA _{MAX})	230V	end switches SPDT 250V 6(3)A	SmokeShield	Power Off – Fail-safe Close
M5 PTC Vent NON ETR	10/2W (12.5VA _{MAX})	24V	end switches SPDT 250V 6(3)A	VentShield	Power Off – Fail-safe Open
M6 PTC Vent NON ETR	12/4W (14VA _{MAX})	230V	end switches SPDT 250V 6(3)A	VentShield	Power Off – Fail-safe Open

*SmokeShield Control Modes M5 PTC and M6 PTC are supplied as standard with the Electrical Thermal Release (ETR) (Not fitted to VentShield). The units Fail-safe by means of the unique and patented ETR device which operates at 72 °C, or if the power supply is off/interrupted. Complying with BS 9999 : 2008 (Ref 33.4.5.3). Non ETR versions Fail-safe when the power is off/interrupted.

Control Mode Details Continued

Control Mode 5 – 3P PTC



Control Mode 5 – 3P PTC with additional facility for third (Control) Position. 150 seconds Reset, 20 seconds Release.

This 3 position control mode allows a damper to be moved to both the reset and release position, with the additional facility to move the damper to a third control position. The mode is given a 2 - 10V DC signal, defining the control position of the blades.

A return signal of 2-10V DC is provided to allow monitoring of position.

To support this actuator and allow positioning to be set local to the damper, Actionair have the **M5-3P 24V and M5-3P 230V control units.**

As with all PTC modes, this series uses the *snaplock™* interface. Fire rated dampers are primarily designed to be fitted into a wall or floor, and the interface displaces the mode from the line of the wall. Dampers may be installed and then the mode removed from storage for easy fitting, thus preventing damage to the mode before it is required. End switches, LSF cable, and Electro Thermal Release (ETR) are provided as standard (not fitted on VentShield).

Versions are available to allow fail-safe close for fire safety or fail-safe open for smoke venting.

Control Monitoring Station

M5-3P 24V and M5-3P 230V CMS Control Stations



M5 – 3P – CMS

M5 – 3P – CMS (230V)

The M5-3P CMS (Control Monitoring Station) this control unit gives the user the opportunity to set a control position using an integral potentiometer, or use an externally supplied control voltage. It provides visual (lamp) and volt free (relay) indication of damper position (Released, at Control Position, Reset). A terminal is provided to allow feedback of the 2-10V DC monitoring voltage. In addition, a fire alarm input may be made (NC) which will cause the damper to Release if the contact is broken. A second input is available to cause the damper to fully Reset to allow full air flow for smoke venting as an example. The fire alarm Release input takes precedence. Switches are provided that allow the unit to be driven to Release or Reset positions for testing purposes.

SmokeShield and VentShield

M5-3P PTC	24V 7/2W (10VA) end switches SPDT 250V 6(3)A	SmokeShield	Thermal Release / Power Off – Fail-safe Close	2-10V Set Position
M5-3P PTC NON ETR	24V 7/2W (10VA) end switches SPDT 250V 6(3)A	SmokeShield	Power Off – Fail-safe Close	2-10V Set Position
M5-3P PTC Vent	24V 7/2W (10VA) end switches SPDT 250V 6(3)A	VentShield	Thermal Release / Power Off – Fail-safe Open	2-10V Set Position
M5-3P PTC Vent NON ETR	24V 7/2W (10VA) end switches SPDT 250V 6(3)A	VentShield	Power Off – Fail-safe Open	2-10V Set Position

SmokeShield Control Modes M5 –3P PTC are supplied with the Electrical Thermal Release (ETR) (Not fitted to VentShield). The units Fail-safe by means of the unique and patented ETR device which operates at 72 °C, or if the power supply is off/interrupted. Complying with BS 9999: 2008 (Ref 33.4.5.3) Non ETR versions Fail-safe when the power is off/interrupted.

Control Mode 5 – 2P PTC and Control Mode 6 – 2P PTC



SmokeShield and VentShield

M5-2P PTC	24V 12W (18VA), end switches SPDT 250V 6(3)A
M6-2P PTC	230V 8W (15VA), end switches SPDT 250V 6(3)A

Drive Open / Drive Closed. 60 seconds operation

This 2 position control mode has been developed to provide drive open / drive closed damper operation. These modes do not have ETRs.

As with all PTC actuators, this series uses the *snaplock™* interface. All modes have LSF cables.

Application and Wiring - Smoke (with ETR)

SmokeShield Mode 1 PTC (Manual System)

Manual opening.
Spring instant closure via mechanical fusible link.

(SmokeShield version only, VentShield not available.)

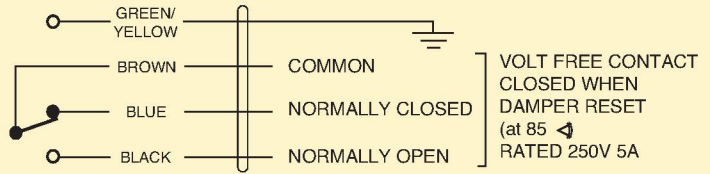

DIAGRAM SHOWS ACTUATOR IN FULLY RELEASED STATE

SmokeShield Mode 5 PTC (24V System)

The following applies for ETR version.
(ETR not supplied on VentShield.)

Supply On – Damper motors reset.
Supply Off – Spring release.
Electrical Thermal Release.
External mechanical position indicator with pointer.
Release Time ≈ 22 secs.
Reset Time ≈ 60 secs.

(Connect 24V via a safety isolating transformer.)

IP54 Rated.

AC/DC 24V
50 / 60 Hz

12.5 VA
10 / 2 W

I_{max}
8.3A @ 5ms

-30...+50 C
CONTINUOUS

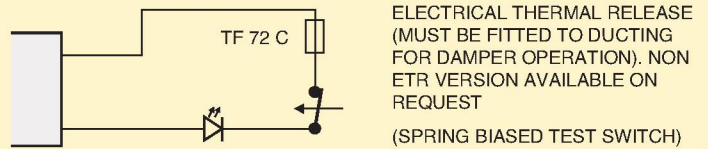
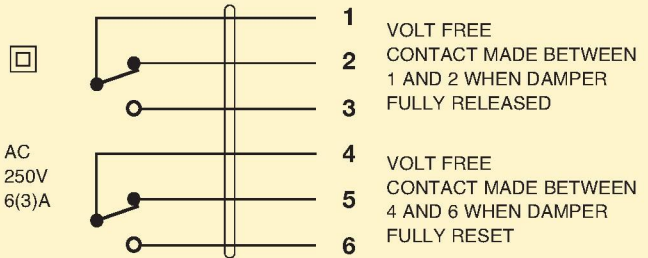
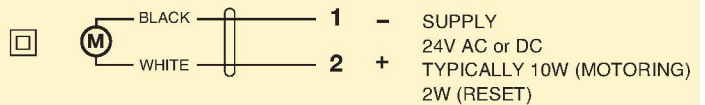

DIAGRAM SHOWS ACTUATOR IN FULLY RELEASED STATE

SmokeShield Mode 6 PTC (230V System)

The following applies for ETR version.
(ETR not supplied on VentShield.)

Supply On – Damper motors reset.
Supply Off – Spring release.
Electrical Thermal Release.
External mechanical position indicator with pointer.
Release Time ≈ 22 secs.
Reset Time ≈ 60 secs.

(To isolate from main power supply, the system must incorporate a device which disconnects the phase conductors, with a least 3mm contact gap.)

Note: 120V A.C. version also available.

IP54 Rated.

AC 230V
50 / 60 Hz

14 VA
12 / 4 W

-30...+50 C
CONTINUOUS

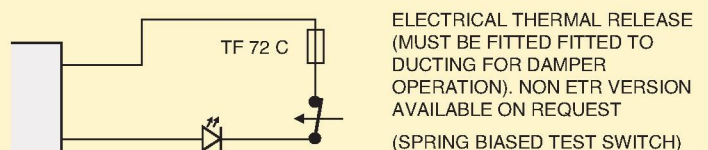
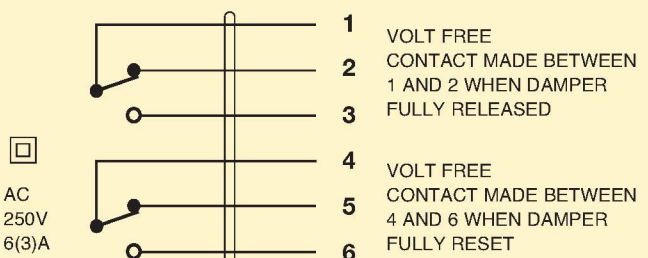
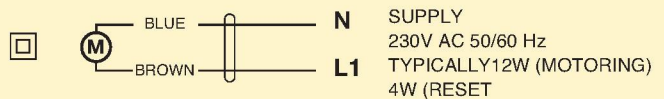

DIAGRAM SHOWS ACTUATOR IN FULLY RELEASED STATE

Application and Wiring - Vent (or Smoke Non-ETR)

VentShield PTC™ Dampers and associated Control Modes M5 and M6 are reverse action with spring opening.

VentShield Mode 5 (24V System)

Supply On – Damper motors reset.
Supply Off – Spring release.

Cable specification:
Si HF Low Smoke and Fume, Halogen Free, to IEC 754-1. Conforming to 73/23/EEC directive.

Release Time ≈ 22 secs.
Reset Time ≈ 60 secs.

(Connect 24V via a safety isolating transformer.)

IP54 Rated

AC/DC 24V
50 / 60 Hz

12.5 VA
10/2 W

I_{max}
8.3A @ 5ms

-30...+50 C
CONTINUOUS

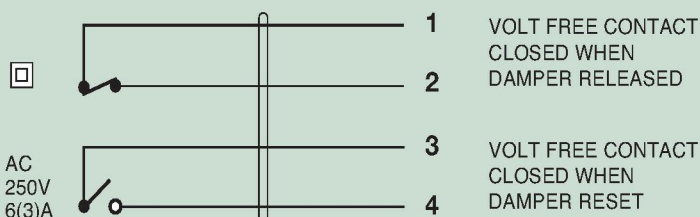
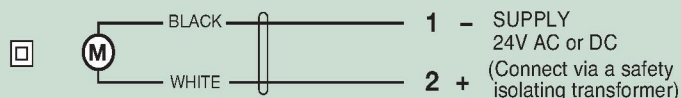

VentShield Mode 6 (230V System)

Supply On – Damper motors reset.
Supply Off – Spring release.

Cable specification:
Si HF Low Smoke and Fume, Halogen Free, to IEC 754-1. Conforming to 73/23/EEC directive.

Release Time ≈ 22 secs.
Reset Time ≈ 60 secs.

(To isolate from main power supply, the system must incorporate a device which disconnects the phase conductors, with a least 3mm contact gap.)

Note: 120V A.C. version also available.

IP54 Rated

AC 230V
50 / 60 Hz

14 VA
12/4 W

-30...+50 C
CONTINUOUS

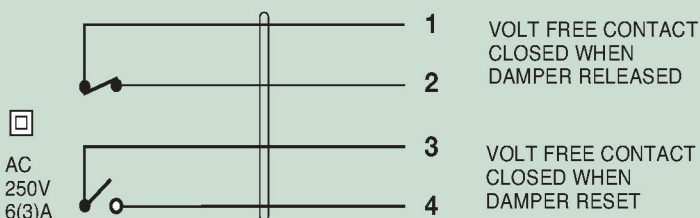
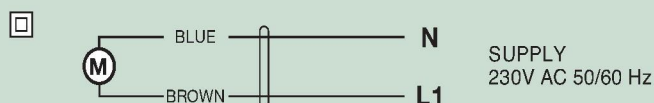

General (Electrical)

One metre of halogen free low smoke and fume electric cable is also included with Control Modes 1, 5 and 6 for convenience of on site wiring. This also provides the distinct safety advantage of all electrics terminating outside the duct, eliminating potential in-duct fire hazards from wiring faults.

(Prewired Connection boxes available as factory fitted option.)

The Electrical Thermal Release is pre-wired with 0.5m halogen free low smoke and fume cable on Control Modes 5 and 6. (Not supplied on VentShield).

A Manual test switch fitted on the ETR allows periodic operation of damper simulating actual fail-safe release under smoke/fire conditions.

Control Modes 5 and 6 are available without the ETR where thermal operation is not required. (This would not comply with BS 9999: 2008).

Smoke Shield or Vent Shield Mode 9 PTC (Pneumatic Operation)



Air On – Damper resets.
Air Off – Spring release.
Release time ≈ 2 – 4 secs.
Reset time ≈ 2 – 4 secs.
Air inlet – 6mm dia. quick fit coupling.
74 °C Pneumatic Thermal Link (PTR).
(PTR not supplied on VentShield.)
Air pressure ≈ 5.5 – 8.0 bar.
Air consumption to reset @ 5.5 bar – 535CC.
External mechanical position indicator.
Test operation by removing fusible link element.

Damper Installation and Control Mode Fitting

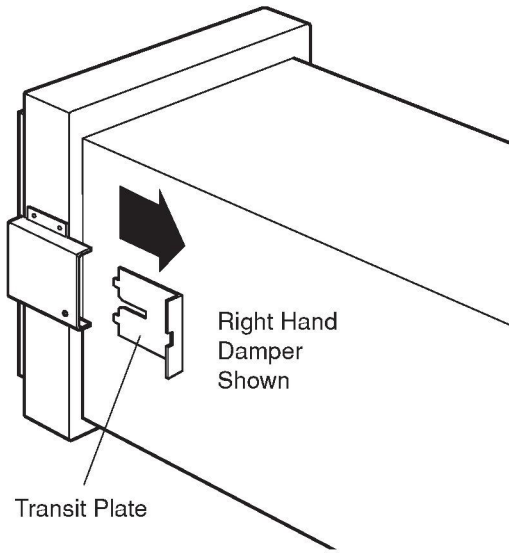

Step 1

Install the SmokeShield PTC™ Automatic Smoke and Fire Dampers (complete with transit plate) into the structure. Refer to the Actionair Approved Fire and Smoke Dampers Installation Manual.

(Care must be taken when back filling to ensure that the snaplock™ retaining pin location hole and the entry slot of the damper drive shroud is clear of builders work debris).

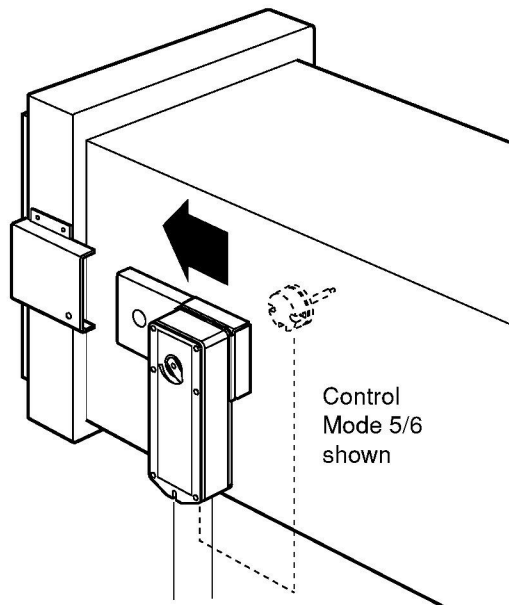

Step 2

Slide the snaplock™ Drive Interface into the damper drive shroud, 'snaplock™' into position.

The 'snaplock™' feature provides a user friendly, easy and secure direct connection. It comes pre-set to enable direct fit to Smoke/VentShield damper.

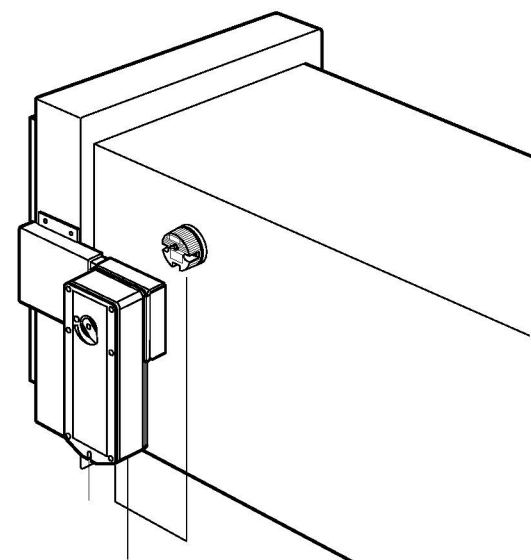

Step 3 For Control Modes with Electrical Thermal Releases.

Identify location for the Thermal Release. Ideally, this should be fitted to the top half of the duct, adjacent to the control mode. Fit the self adhesive drilling template (supplied) in this position. Drill holes as detailed on the template. Using the 2 fixing screws provided, secure the Electrical Thermal Release to the duct. Connect electrically, and test operation.

As a safety feature the actuator will only operate if the ETR is correctly fitted to the duct.

Damper Installation and Control Mode Fitting Continued

Step 3 (Control Mode 1) SmokeShield only

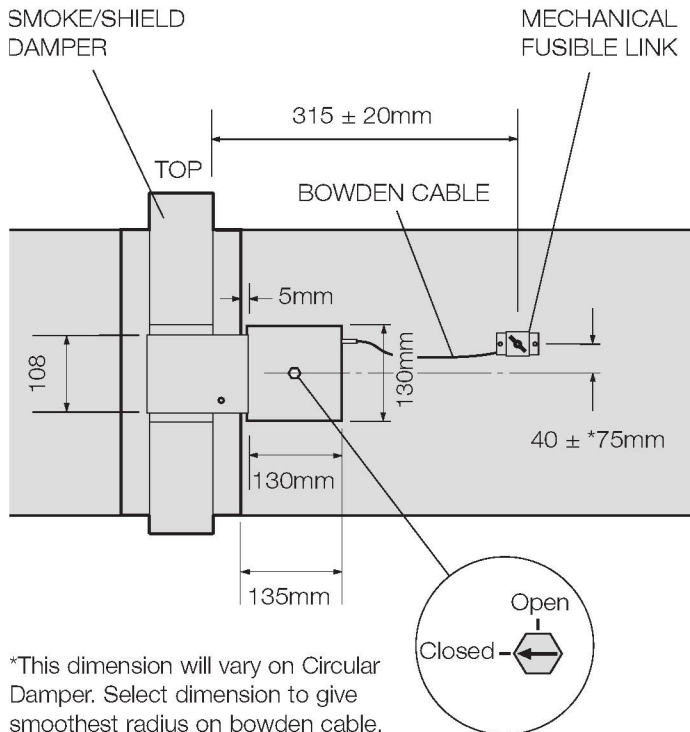

Mark the Fusible Link position on the duct as dimensioned in the diagram above.

Fit the self adhesive drilling template (supplied) in this position. Drill holes as detailed on template. Using the 2 fixing screws provided, secure the Fusible Link to the duct. Reset Damper using a 14mm A/F spanner, clockwise 1/4 turn. Test unit by simply unscrewing wing nut – Damper releases. For ductless installations a suitable sized plate or bracket must be fitted to the installation to allow the fitting of the Fusible Link.

As a safety feature the Control Mode will only operate if the Fusible Link is correctly fitted to the duct.

Step 3 (Control Mode 9)

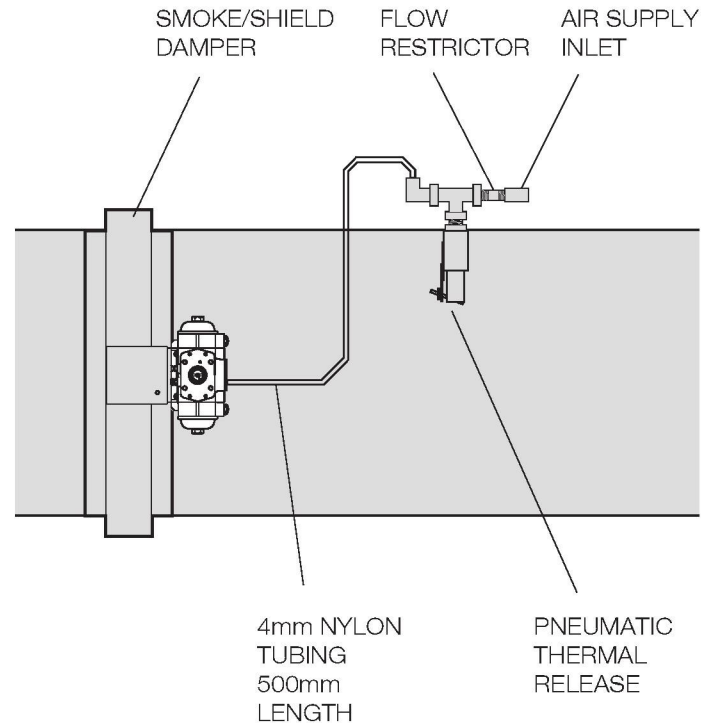

1. Select position for PTR. (SmokeShield only). Ideally this should be in the top half of the duct and sufficiently close to the actuator to allow easy connection of the 4mm diameter nylon tube supplied.
2. Drill hole in selected position using a 30mm diameter hole cutter, removing any sharp edges.
3. Position PTR and drill the 4 off 3mm diameter fixing holes.
4. Remove PTR and apply approved fire retardant sealant on the duct around the hole.
5. Refit PTR and secure with the 4 off Pozi head screws provided.
6. Connect 4mm diameter tube to actuator and PTR.
7. Connect 6mm diameter tube to input side of PTR.
8. Connect air supply. Damper opens fully.
9. Test operation.

Installation Methods, Classification and Test Report Summary

DWFX™ (DRY WALL FIX) Installation System

Typically for installation into Dry Wall, Stud Partitions.

HEVAC / HVCA Galvanised Steel Installation Frames

Typically for installation into Blockwork, Concrete walls and floors.

S&A Sleeve and Angle Installation System.

Typically used to fill voids around dampers to complete a penetration seal.

DWFX-F Flange + Cleats Dry Wall

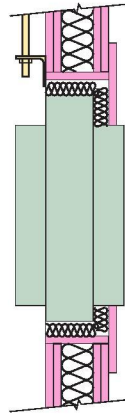

DWFX-F Flange + Cleats Masonry Wall

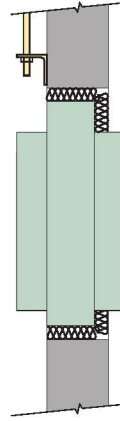

DWFX-C Dry Wall - Cleats

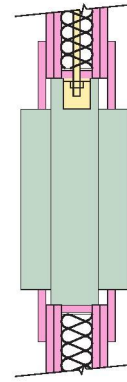

Classification
E120, ES120

BSEN 1366-2 Test / Assessment
BRE 256493

Classification
E120, ES120

BSEN 1366-2 Test / Assessment
BRECC 270714A

Classification
E120, ES120

BSEN 1366-2 Test / Assessment
BRE 231741

S&A Sleeve and Angle + BATT + Dry Wall

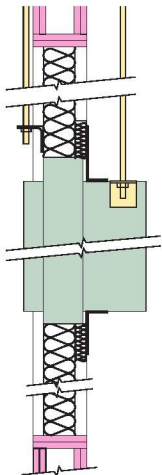

S&A Sleeve and Angle + BATT + Masonry Wall

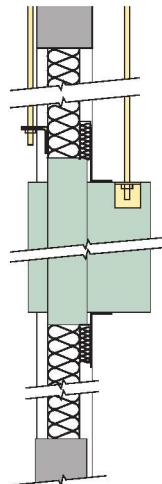

S&A Sleeve and Angle Dry Wall

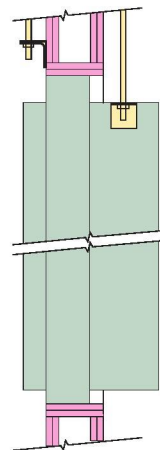

S&A Sleeve and Angle Masonry Wall

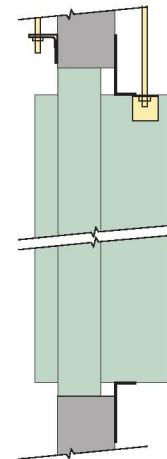

Classification
E120, ES120

BSEN 1366-2 Test / Assessment
BRE 267924

Classification
E120, ES120

BSEN 1366-2 Test / Assessment
BRECC 270714A

Classification
E120, ES120

BSEN 1366-2 Test / Assessment
BRECC 270714A

Classification
E120, ES120

BSEN 1366-2 Test / Assessment
BRECC 270714C

HEVAC / HVCA Installation
Frame Vertical

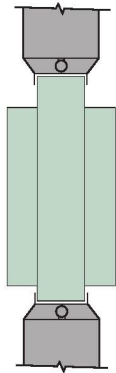

HEVAC / HVCA Installation
Frame Horizontal

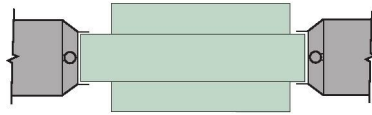

S & A Sleeve and Angle
+ BATT Horizontal

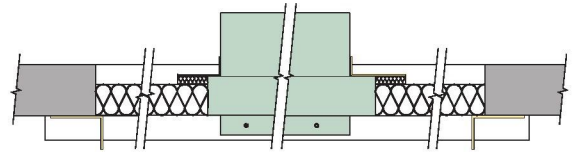

Classification
E240, ES120

**BSEN 1366-2 Test /
Assessment**
BRE 259933

Classification
E240, ES240

**BSEN 1366-2 Test /
Assessment**
BRE 231740

Classification
E120, ES90

**BRE 275926 Test /
Assessment**
BRE 275926

Approved Installations

The Actionair Approved Fire and Smoke Dampers Installation manual is available for free download, along with DW 145 check sheets, on our web site.

Building and Local Authority control, cannot refuse these tested methods.



Accessories

A range of indicator panels, push button switches and damper test units are also available. The housing for these units are manufactured in rigid ABS plastic. The Damper Connection Box is in galvanised steel.

Electrical

	Damper Test Unit Reset and release indication. Spring bias (power OFF) test switch. Power normally ON.	DTU24	24V AC/DC
		DTU120	120V AC
		DTU230	230V AC
	Damper Status Indicator Reset and release indication.	DSI24	24V AC/DC
		DSI120	120V AC
		DSI230	230V AC
	Damper Control Unit Switch ON/OFF function. Reset and release indication.	DCU24	24V AC/DC
		DCU120	120V AC
		DCU230	230V AC
	Damper Release and Indication Module (DRIM) This is designed for control and monitoring of the electrically operated Smoke Shield PTC™ Fire and Smoke dampers. It will operate from 24V, 120V or 230V supplies, 50 or 60 Hz. Selection of the operating voltage is by use of internal links on the PCB,	prior to installation and connection of actuator and supply. The DRIM may be used singly to provide local damper control, or in pairs to provide control from either side of a damper. It can also operate 2 actuators when dampers are provided in 2 multiple sections.	LED position and operation indication is provided. Operation is by push button to close and twist to re-open damper. Tested to BS EN 61010 -1: 2001 and is CE compliant. IP44 rated. Operating range 5 - 40 °C.
		DRIM	24V – 230V AC/DC
	M5 and M6 – 2P Damper Control Unit Switch power open/power close. Open and closed indication.	M52PDCU	24V AC/DC
		M62PDCU	230V AC
	Damper Connection Box (All Voltages).	DCB	24V – 230V AC/DC
	M5 – 3P – CMS Control Unit	M53PCMS	24V AC/DC
	230V M5 – 3P – CMS Control Unit	230V M53PCMS	230V AC
Pneumatic			
	Solenoid, (24V, 120V, or 230V). EEXD Solenoid, (24V, 120V, or 230V). Damper Status Beacon. Switchbox and Status Beacon. Zone 2 Switchbox and Status Beacon.		24 – 230V AC/DC

Control Mode Dimensions and Orientation

Mode 1 (SmokeShield only)

SmokeShield PTC™ Control Modes are located outside of the ductwork for ease of access and installation.

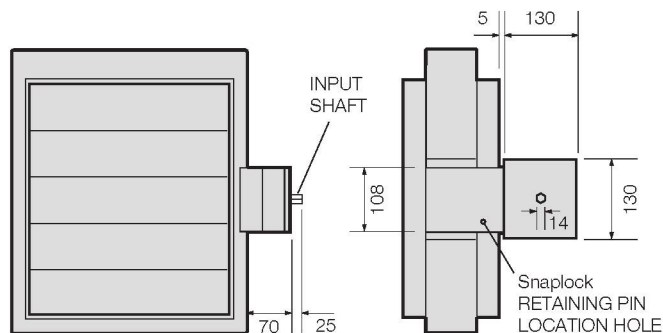

Modes 5 and 6 Three position 180° (Pivotable Control Mode)

SmokeShield PTC™ Control Modes are located outside of the ductwork for ease of access and installation.

Control Modes 5 and 6 can be fitted in any one of three orientations i.e.

- Vertically down (Position 1)
- Horizontally (Position 2), or
- Vertically up (Position 3).

This can be simply and easily carried out on site, by repositioning the Location Plate (see page 2) and Control Mode on to the *snaplock™* Drive Interface.

This flexibility ensures that the damper and control mode require the minimal amount of room.

(Supplied in position 2 as standard.)

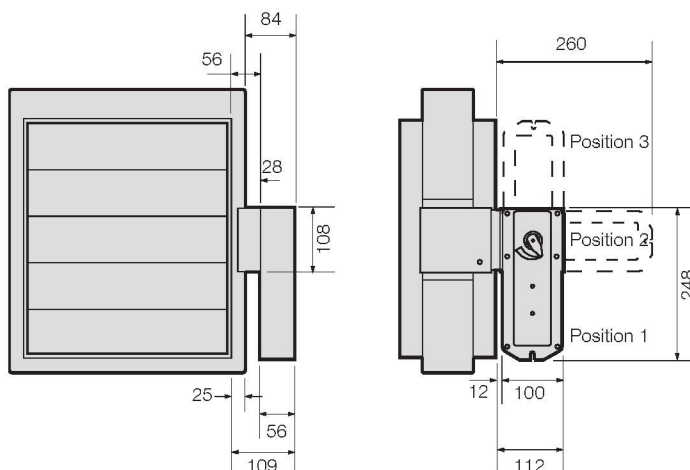

Mode 9 Pneumatic Control

SmokeShield PTC™ Control Modes are located outside of the ductwork for ease of access and installation.

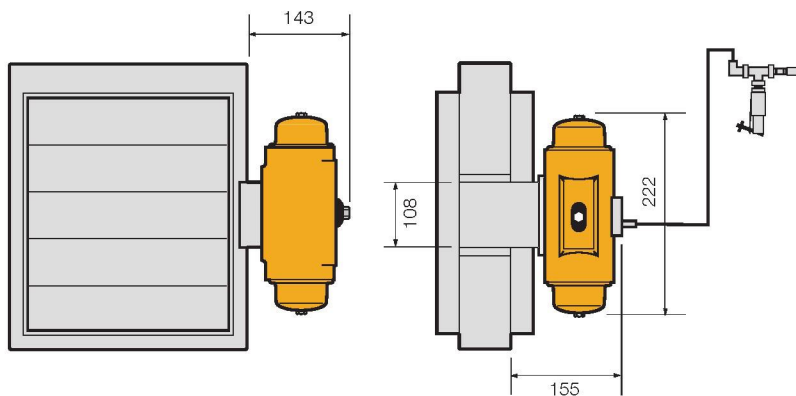

Hytock - 71 (ATEX)
Aluminium Switch Box

Hytock - 71 (ATEX)
Polycarbonate Switch Box

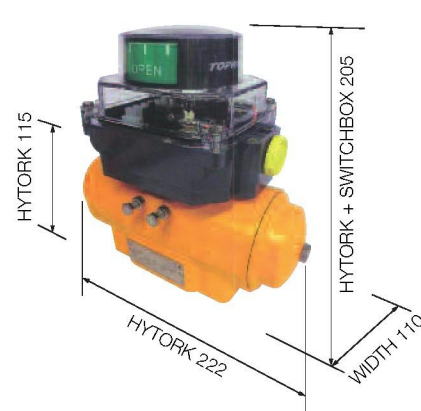
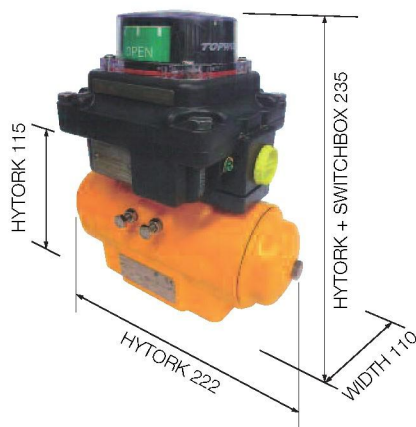

Dimensional Data

For Rectangular Dampers spigots are 5mm under duct size.
 * Widths and heights available in 1mm increments.

Please refer to the Actionair Approved Fire and Smoke Dampers Installation Manual.

Base Dampers

Dampers with Installation Systems

Rectangular Dampers Series 501 and 1501

For Ducts with widths of 100 – 150mm* **For Ducts with heights of 100 – 150mm***

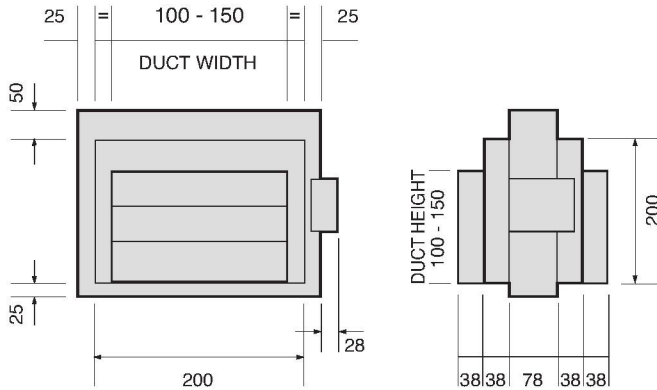

Dampers with DWFX-F

OVERALL FLANGE WIDTH IS 398mm
 OVERALL FLANGE HEIGHT IS 395mm

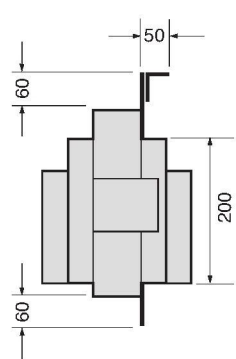

HEVAC / HVCA IF

OVERALL WIDTH OF INSTALLATION FRAME IS 314mm
 OVERALL HEIGHT OF INSTALLATION FRAME IS 340mm

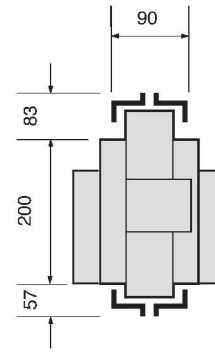

Dampers with S&A

OVERALL FLANGE WIDTH IS 398mm
 OVERALL FLANGE HEIGHT IS 395mm

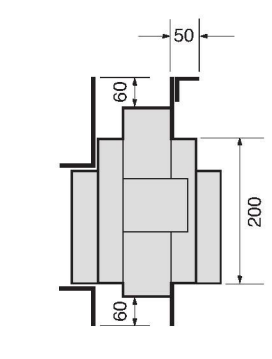

For Ducts with widths of 151 – 199mm* **For Ducts with heights of 151 – 199mm***

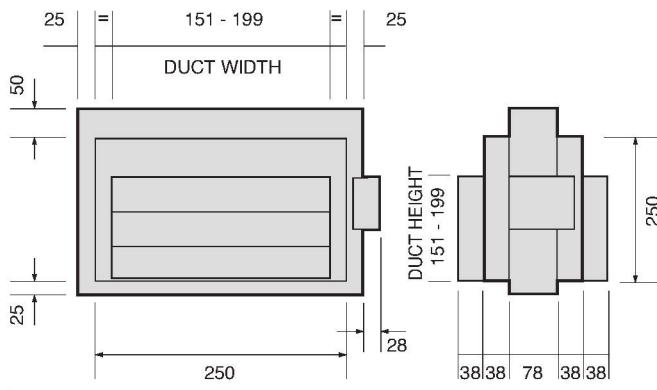

OVERALL FLANGE WIDTH IS 448mm
 OVERALL FLANGE HEIGHT IS 445mm

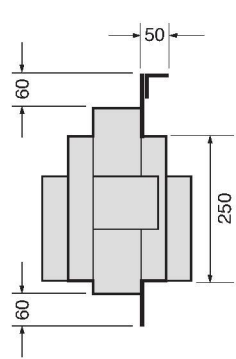

OVERALL WIDTH OF INSTALLATION FRAME IS 364mm
 OVERALL HEIGHT OF INSTALLATION FRAME IS 390mm

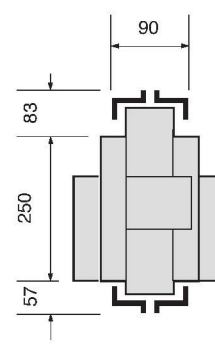

OVERALL FLANGE WIDTH IS 448mm
 OVERALL FLANGE HEIGHT IS 445mm

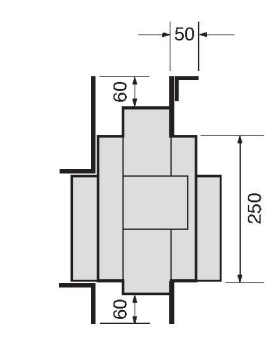

For Ducts with widths and heights of 200 – 1000mm*

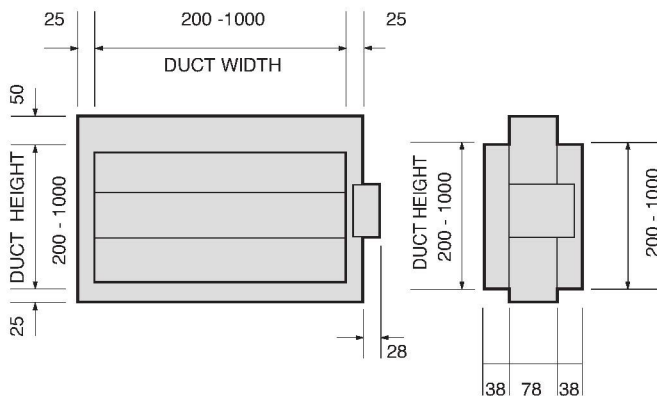

OVERALL FLANGE WIDTH DUCT WIDTH + 198mm
 OVERALL FLANGE HEIGHT DUCT HEIGHT + 195mm

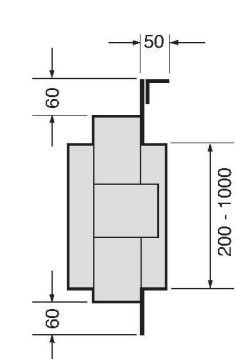

OVERALL WIDTH OF INSTALLATION FRAME DUCT WIDTH + 114mm
 OVERALL HEIGHT OF INSTALLATION FRAME DUCT HEIGHT + 140mm

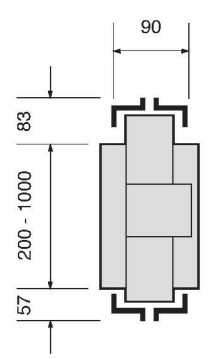

OVERALL FLANGE WIDTH DUCT WIDTH + 198mm
 OVERALL FLANGE HEIGHT + DUCT HEIGHT + 195mm

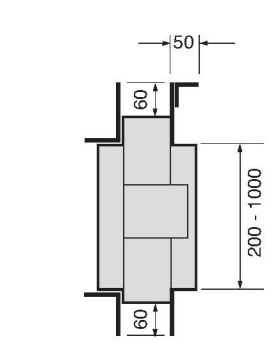

For Circular and Flat Oval Dampers spigots are 3mm under duct size. *Diameters and flat oval diameters in 1mm increments.

For Installation Details Please refer to the Actionair Approved Fire and Smoke Damper Installation Manual.

Base Dampers

Dampers with Installation Systems

Circular Dampers Series 601 and 1601

1mm Increments *

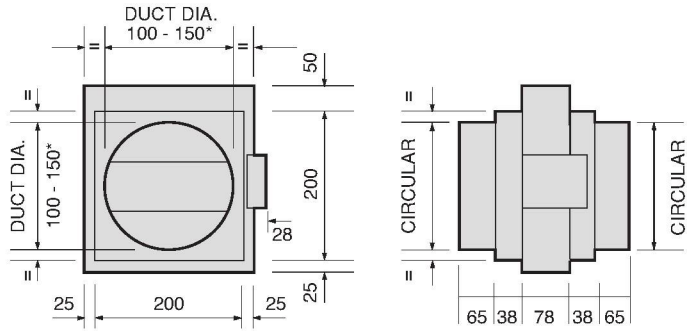

Dampers with DWFX-F HEVAC / HVCA IF

OVERALL FLANGE WIDTH IS 398
OVERALL FLANGE HEIGHT IS 395mm

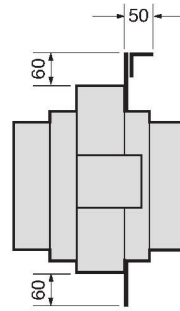

HEVAC / HVCA IF

OVERALL WIDTH OF INSTALLATION FRAME IS 314mm
OVERALL HEIGHT OF INSTALLATION FRAME IS 340mm

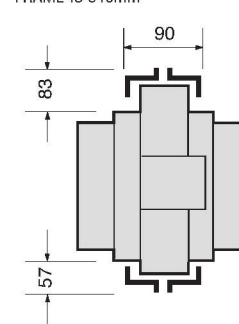

Dampers with S&A

OVERALL FLANGE WIDTH = 448mm
OVERALL FLANGE HEIGHT = 445mm

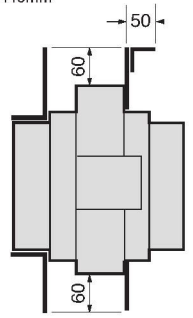

1mm Increments *

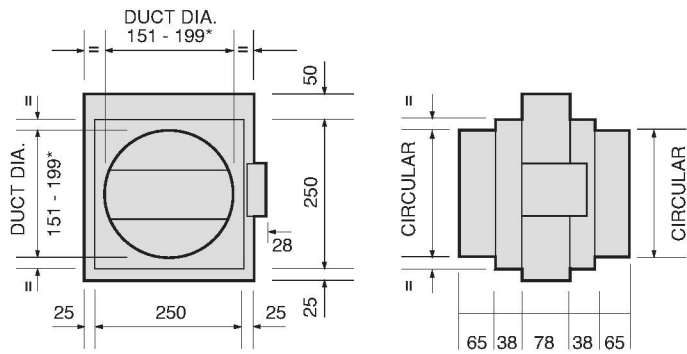

OVERALL FLANGE WIDTH IS 448mm
OVERALL FLANGE HEIGHT IS 445mm

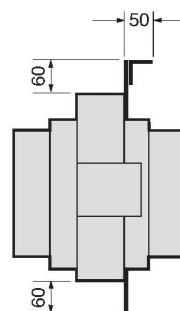

OVERALL WIDTH OF INSTALLATION FRAME IS 364mm
OVERALL HEIGHT OF INSTALLATION FRAME IS 390mm

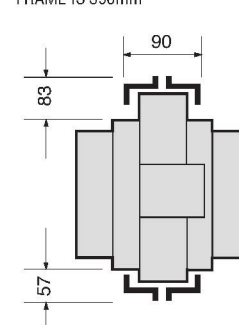

OVERALL FLANGE WIDTH = 448mm
OVERALL FLANGE HEIGHT = 445mm

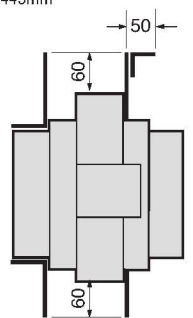

1mm Increments *

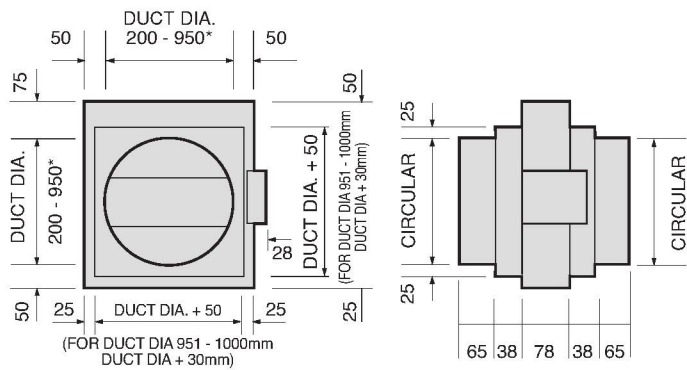

OVERALL FLANGE WIDTH = DUCT DIA + 248mm
OVERALL FLANGE HEIGHT = DUCT DIA + 245mm

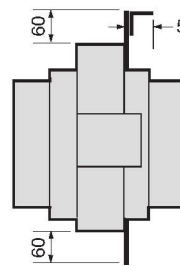

OVERALL WIDTH OF INSTALLATION FRAME = DUCT DIA + 114mm
OVERALL HEIGHT OF INSTALLATION FRAME = DUCT DIA + 190mm

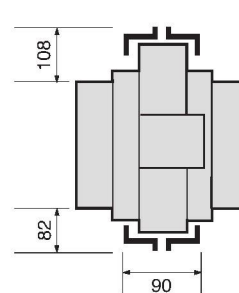

OVERALL FLANGE WIDTH = DUCT DIA + 248mm
OVERALL FLANGE HEIGHT = DUCT DIA + 245mm

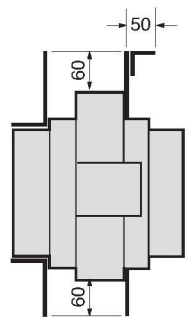

Flat Oval Dampers Series 701 and 1701

1mm Increments *

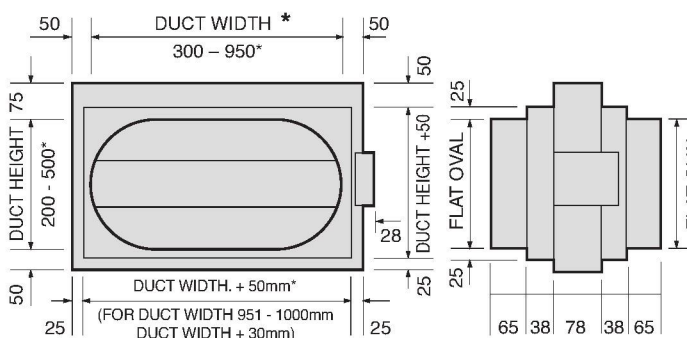

OVERALL FLANGE WIDTH = DUCT WIDTH + 248mm
OVERALL FLANGE HEIGHT = DUCT HEIGHT + 245mm

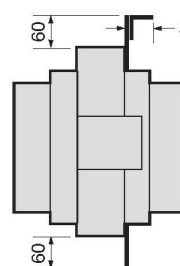

OVERALL WIDTH OF INSTALLATION FRAME = DUCT WIDTH + 114mm
OVERALL HEIGHT OF INSTALLATION FRAME = DUCT HEIGHT + 190mm

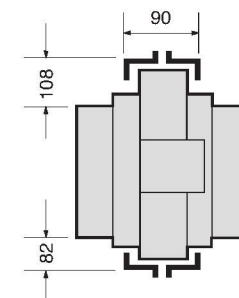

OVERALL FLANGE WIDTH = DUCT DIA + 248mm
OVERALL FLANGE HEIGHT = DUCT DIA + 245mm

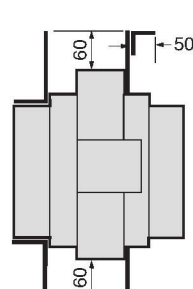

DWFX-C Dimensional Data

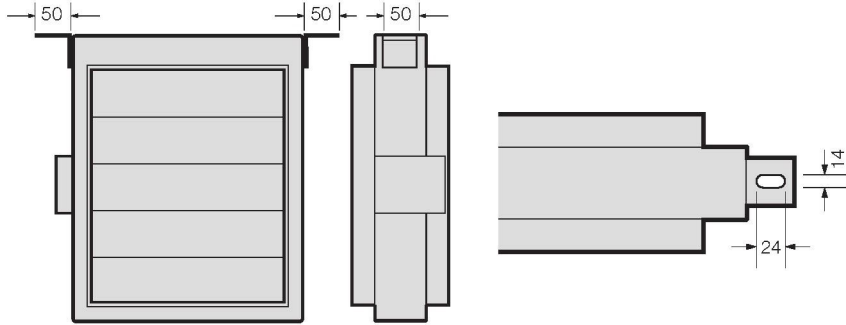

Acoustic Data

The data presented is from the Laboratory Determination of Acoustic and Aerodynamic Performance of SmokeShield PTC Automatic Smoke and Fire Control Dampers.

A programme of extensive tests was carried out in the Reverberation Chamber and North Transmission Chamber of Sound research Laboratories Limited, Holbrook Hall, Sudbury, Suffolk, generally in accordance with BRITISH STANDARDS Nos. 4196, 4773, 4856, 4857 and 4954.

This independent test facility is approved under the NAMAS Scheme.

From the selection of a duct velocity within the operational parameters of the damper a resultant pressure drop from Graph 1 can be determined and the sum of these two components applied to the Velocity x Pressure Drop Vs Sound Power Level Graph. (Graph 2)

The graph is the result of a full range of acoustic tests on SmokeShield PTC™ Automatic Smoke and Fire Control Dampers with the blades set in their fully open position.

The Spectrum Correction Data is applied to the number obtained from the graph and a complete Sound Spectrum of Flow Generated Noise for both Outlet (in duct) and Breakout (casing radiated) can be obtained from Table 1.

Pressure Drop Vs Velocity

Graph 1

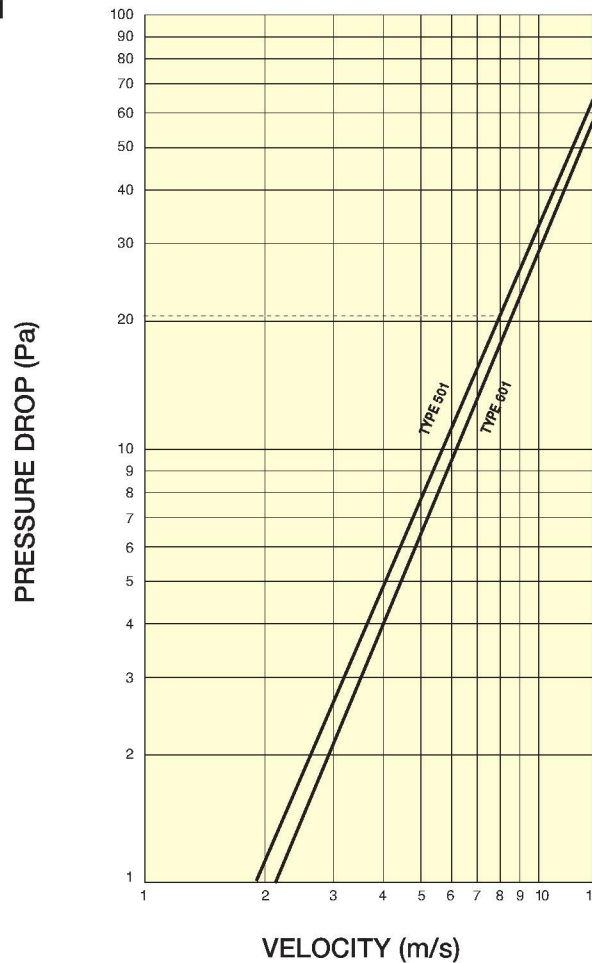

Example:

Duct with a design velocity of 8 m/sec. SmokeShield PTC Damper Series 501 fully open.

Pressure Drop = 21 Pa (Graph 1).
 Multiply Velocity x Pressure Drop
 $8 \times 21 = 168$.

From Sound Power Graph (Graph 2) plot 168 on horizontal Velocity/Pressure axis against 501 outlet (induct) graph to obtain 47 dBW on Vertical Sound Power Level Axis. Add or subtract corrections to the 47 dBW to provide full spectrum analysis using appropriate Correction Table.

Velocity (m/s) X Pressure Drop (Pa) Vs Sound Power Level (dBW)

Graph 2

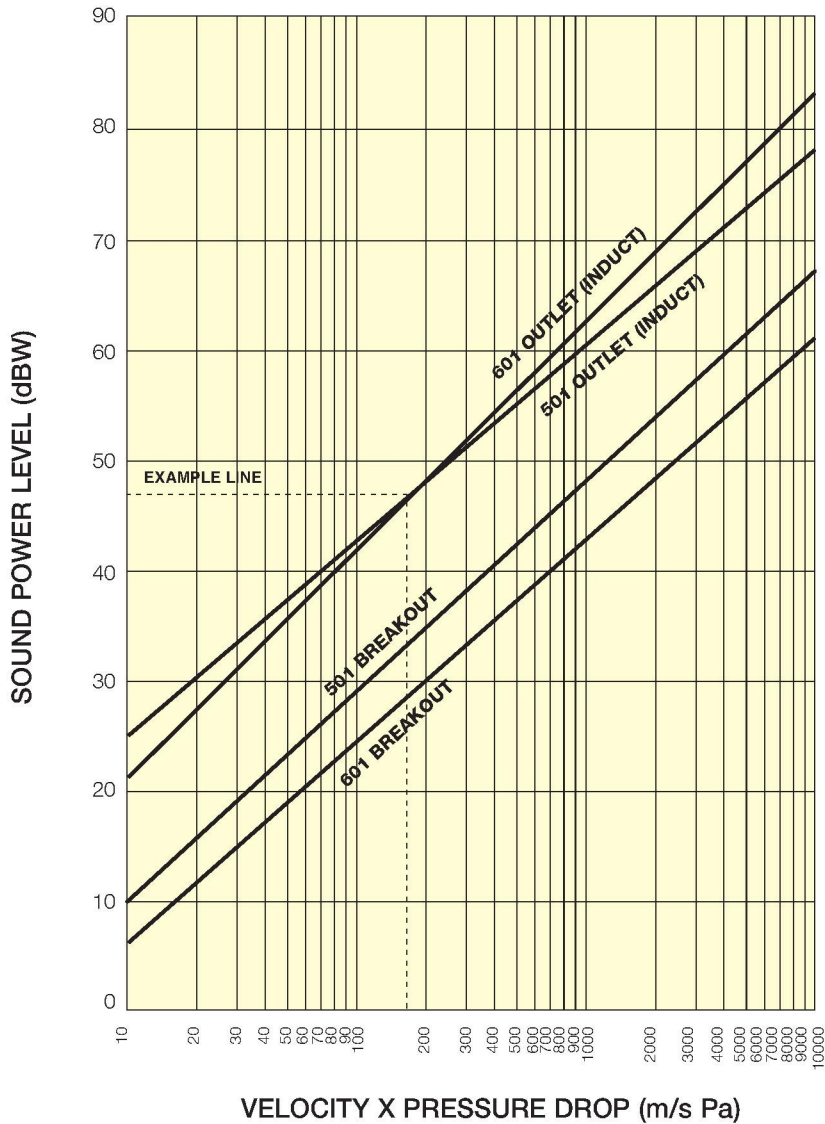

Correction Tables

Table 1

SmokeShield PTC™ Outlet (Induct) Spectrum Corrections

Octave Band	Hz	63	125	250	500	1k	2k	4k	8k
Series 501	dB	5	4	5	5	3	1	-3	-5
Series 601	dB	9	4	4	5	3	1	-3	-6

Table 2

SmokeShield PTC™ Breakout Spectrum Corrections

Octave Band	Hz	63	125	250	500	1k	2k	4k	8k
Series 501	dB	8	11	9	6	-3	-6	-14	-17
Series 601	dB	6	10	8	4	-3	-3	-11	-14

Damper Leakage

Graph 3

SmokeShield PTC™ and VentShield PTC™ closed blade leakage as tested on a damper 1000mm wide x 1000mm high.

Leakage data at Ambient temperature (Cold Smoke).

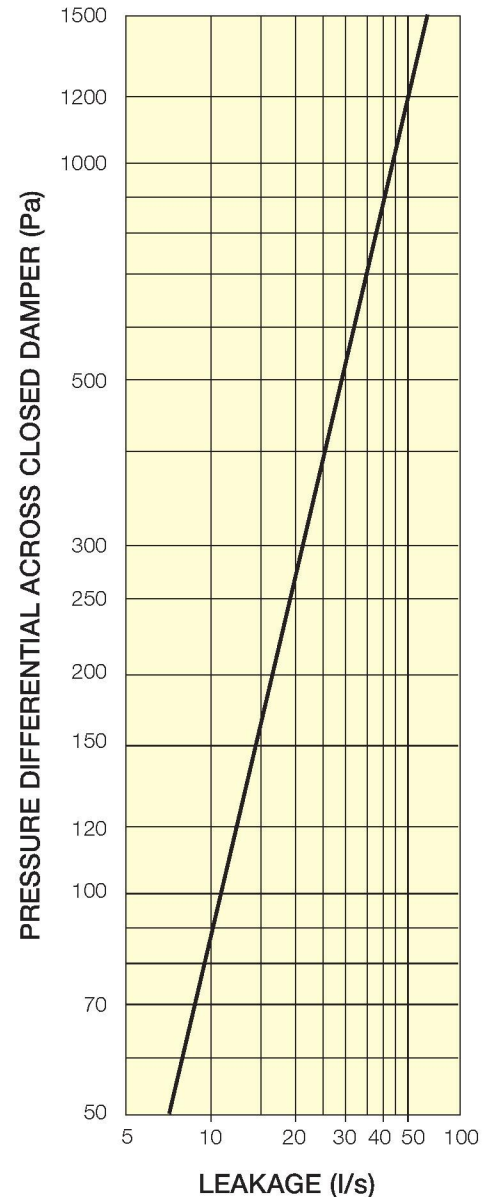

The SmokeShield PTC™ Damper has been tested in accordance with BS ISO 10294-1 and BS EN 1366-2. It achieved ES classification in accordance with BS ISO 10294-2:1999. ES classification allows a maximum of 200m³/Hr/m² (corrected to 20 °C) hot gas leakage throughout the test at 300 Pa pressure differential across the damper.

Actionpac Damper Control Systems

Electro Mechanical Systems

Actionpac EMS - Standard Control and Monitoring System

Control and monitoring of Mode 5 or Mode 6 damper actuators in groups of 12, 24 or 36.

Actionpac EMB - Bespoke Control and Monitoring System Control Panel

The EMB Control Panels typically consists of the appropriate number of switches to provide individual or group control, LED indication for status monitoring and all necessary relays and timers to comply with the customer needs for fully or semi automatic damper operation. The EMB panels are purposely manufactured for any particular project to suit specific client requirements.

Addressable Systems

Actionpac LNS Smart Cost Effective Intelligent Damper Control and Monitoring System

Actionpac Smart for the control/monitoring of up to 36 off SmokeShield dampers.

Actionpac 60/120 (LNS 60/120) Intelligent Damper Control and Monitoring System

Actionpac 60 for the control/monitoring of up to 60 off SmokeShield dampers.

Actionpac LNS 120 for the control/monitoring of up to 120 off SmokeShield dampers.

Actionpac LNS3 Intelligent Damper Control and Monitoring System

The Actionpac LNS3 system represents a new generation of smoke/fire damper control. The system has been designed with the user in mind, providing an advanced tool that simplifies installation and commissioning of smoke/fire dampers and peripheral devices. The Panel PC operates on a Windows™ platform making it universally accepted and utilises solid state technology for optimum reliability.

It's server architecture delivers new benefits such as reduced commissioning time, simplified operation and scope for future growth.

The Actionpac LNS3 system is designed to protect life and property from damage caused by smoke and fire, by providing the means to:-

- Compartmentalise fire zones.
- Reduce the spread of smoke and fire.
- Keep escape routes and fire-fighting access open.
- Allow pressurisation and smoke extract by combined operation of dampers and fans.

Benefits

- Actionair experience and know-how in the damper market
- Actionair Smoke/Fire Dampers LPCB approved
- Allows for phased commissioning and future expansion
- Backward compatible
- CE marked, EMC and LVD compliant
- Customer testimonials available
- Hundreds of prestigious reference sites
- Powerful and very flexible functionality

accommodates any last minute changes to strategy, zones, damper quantities, references and descriptions etc and enables standardisation of software (no bespoke site specific versions required)

- Off site system witnessing can be arranged
- Open and interoperable protocol (LonWorks®) allows possible support by others and future proof lifecycle preventative maintenance costs
- Optional networking of panels to a central control and monitoring panel - up to 32 networked panels to meet practically any building's damper requirements
- Optional automatic scheduled damper testing, including omit option for critical dampers
- Optional remote access via internet
- System designed to cater for environmental occupancy (energy saving) as well as the building's smoke/fire strategy



Actionpac LNS3 Intelligent Damper Control and Monitoring System

Fully comprehensive brochures are available on all Actionpac products. Visit the Actionair website [w.w.actionair.co.uk](http://www.actionair.co.uk) and download the relevant pdf.

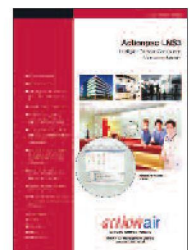
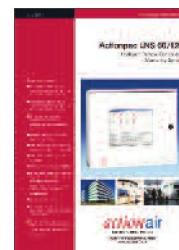
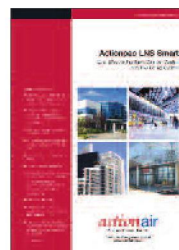

Typical Network Schematic

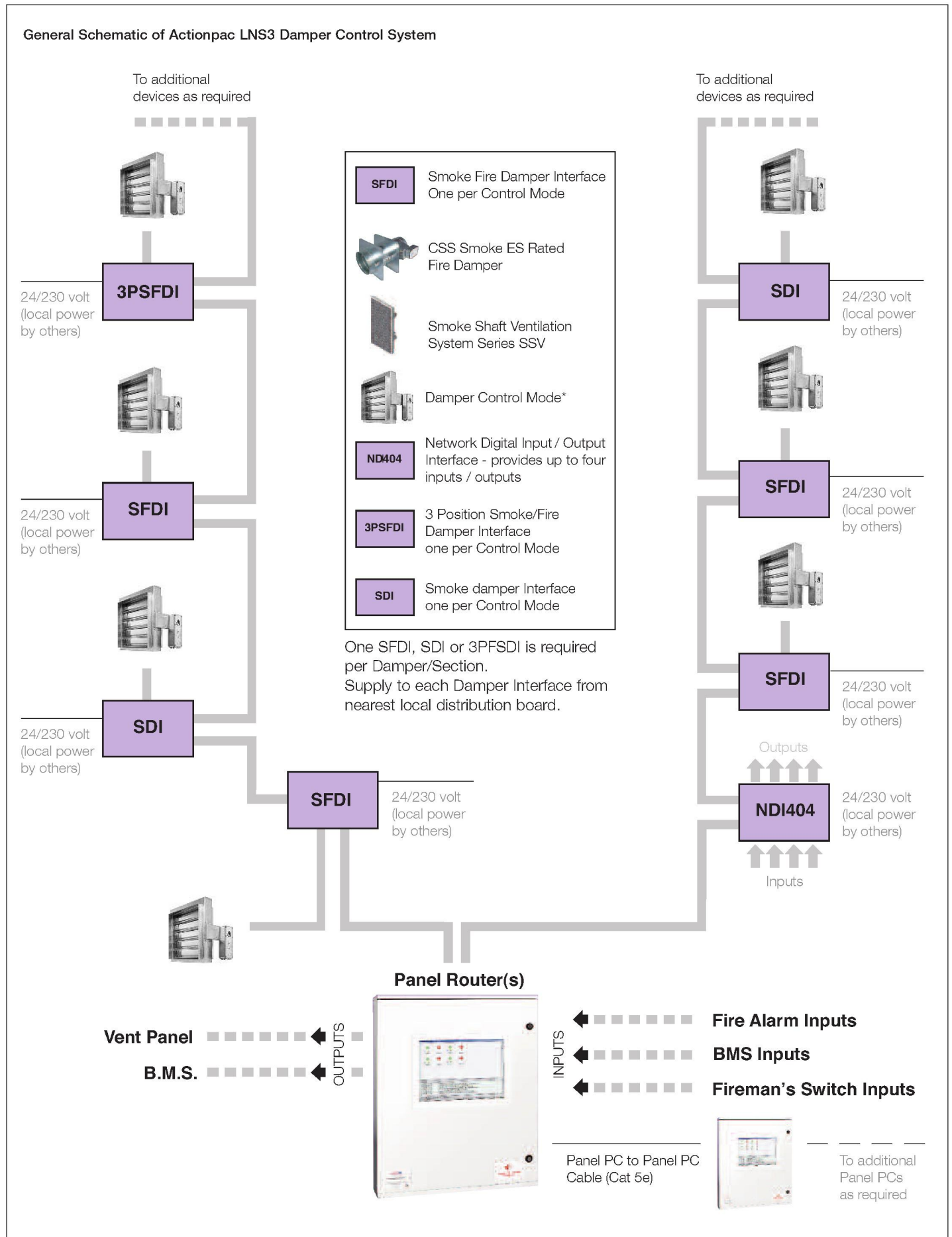

Customer Service

Actionair provides quality products backed by a dedicated team committed to providing the very best in customer service.

Offering experienced technical backup, comprehensive sales and administrative customer support, product commissioning and maintenance service.

Maintenance

The SmokeShield PTC™ Dampers are designed for applications in normal dry filtered air systems and should be subjected to a planned inspection programme, with cleaning and light oil lubrication in accordance with BS9999. When exposed to fresh air intakes and/or inclement conditions this may need to be performed more regularly based on experience gained from previous inspections.

Approvals

Approved by LPCB for use in up to 4 hour constructions.

Refer to the Actionair Approved Fire and Smoke Dampers Installation Manual.

The SmokeShield PTC™ Damper tested and assessed to BS ISO 10294-1, BS EN 1366-2 and BS 476 pt. 20. It achieved ES classification in accordance with BS ISO 10294-2:1999.

Low gas/smoke and fire integrity to Classification ES in vertical and horizontal test installations.

An LPCB approved product, compliant to the new Loss Prevention Council Design Guide for Fire Protection of Buildings.

Fire tested in vertical and horizontal applications under dynamic conditions by The Loss Prevention Council.

Corrosion tested to BS EN 60068-2-52: 1996 to satisfy the requirements within LPS 1162.

Complies with the latest DW 144 casing leakage specification.

The Electrical Control Modes satisfy requirements of the following standard(s) or other normative documents, EN 6100-6-2 / EN 6100-6-3 / EN60730-1 / EN 60730-2-14 following the provision of Directive 2004/108/EG, 2006/95/EG.

Seismic Qualification

SS501PTC, have been subjected to triaxial seismic qualification tests in accordance with BNFL Technical Services Report ET 372 Schedule No. Twelve, to the levels detailed in Costain Document 6733-0250-064-10-0020, Rev C, Specification for Diesel Generator and Load Bank. The testing was also in general accordance with IEEE 344-2004 IEEE Recommended Practice for Seismic Qualification of Class 1E Equipment for Nuclear Power Generating Stations – Time History Method.

Quality Assurance



Approximate Weights (Kg)

Square or Circular Duct Size (mm)	100	150	200	250	300	350	400	450	500	550	600	650	700	750	800	850	900	950	1000
Series 501 Square	3.4	3.4	3.4	4.2	4.8	5.6	6.5	7.4	8.6	9.6	10.8	12.4	13.6	14.9	16.2	17.7	19.2	20.8	23.5
Series 501 Square + I/F	6.2	6.2	6.2	7.4	8.7	10.3	11.9	13.2	14.6	16.3	18.5	20.5	22.1	24.0	25.9	28.1	30.3	32.4	34.5
Series 601 Circular	5.3	5.3	5.3	6.1	7.2	8.4	9.6	11.2	12.6	14.0	15.9	17.5	19.1	20.7	22.5	24.3	26.2	29.3	32.1
Series 601 Circular + I/F	8.5	8.5	8.5	10.0	11.9	13.7	15.4	17.1	19.2	21.8	24.0	26.0	28.2	30.4	32.8	35.3	37.8	40.3	43.1

Control Mode 1 (SmokeShield only) (including drive interface) 4.1Kg

Control Modes 5, 5 - 3P, 5 - 2P, 6, 6 - 2P and 9 (including drive interface) 4.4Kg

The information contained herein is subject to change without notice due to continuing research and development.

Ordering Information

Example

Quantity	Series	Fixing Options	Duct Size	Control Mode	Accessories
3	SS501/PTC	IF	600(W) x 450(H)	M5	
Number of units required	SS 501/PTC SmokeShield PTC™ Square or Rectangular (Fail-safe closed)	1. DWFX-F Dry Wall Fixing System Flange plus Cleats	M1 PTC Manual System		Electrical
	SS 601/PTC SmokeShield PTC™ Circular (Fail-safe closed)	2. DWFX-C Dry Wall Fixing System Cleats	M5 PTC 24V 10W (12.5VA)		1. DTU Damper Test Unit Damper Test Unit For Control Modes. Spring bias test switch providing illuminated reset and release status
	SS 701/PTC SmokeShield PTC™ Flat Oval (Fail-safe closed)	3. IF HEVAC / HVCA Installation Frame	M6 PTC 230V 12W (14VA)		2. DSI Damper Status Indicator Reset and Release Indication
	VS1501/PTC VentShield PTC™ Square or Rectangular (Fail-safe open)	4. Sleeve plus Angle	M5 PTC Vent NON ETR 24V 10W (12.5VA)		3. DCU Damper Control Unit Damper Control Unit for Control Modes. Switch ON/OFF function, reset and release indication
	VS 1601/PTC VentShield PTC™ Circular (Fail-safe open)	5. Other Special Fixings	M6 PTC Vent NON ETR 230V 12W (14VA)		4. DRIM Damper Release and Indication Module
	VS1701/PTC VentShield PTC™ Flat Oval (Fail-safe open)		M5 PTC NON ETR 24V 10W (12.5VA)		5. M52PDCU / M62PDCU Switch Power Open/Power Close. Open and Closed Indication
			M6 PTC NON ETR 230V 12W (14VA)		6. DCB Connection Box For Control Modes 1, 5 and 6 (see page 10 for above)
			M5 PTC Vent 24V 10W (12.5VA)		7. M5 – 3P - CMS Control Unit
			M6 PTC Vent 230V 12W (14VA)		8. 230V M5 – 3P - CMS Control Unit
			M5-2P ON/OFF 24V 7W (10VA)		Pneumatic
			M6-2P ON/OFF 230V 8W (12.5VA)		24 Volt Solenoid, (24, 120, or 230 Volt). Status Beacon, Switchbox and Status Beacon. PTR XNNN05017
			M5-3P PTC 24V 7W (10VA)		Mechanical
			M5-3P PTC Vent NON ETR 24V 7W (10VA)		<i>snaplock™</i> Interface Locking Plate (See page 10)
			M5-3P PTC NON ETR 24V 7W (10VA)		Actionpac Damper Control Systems
			M5-3P PTC Vent 24V 7W (10VA)		(See page 20 and 21)
			M9 PTC Pneumatic Operation		
			M9 PTC Vent NON PTR Pneumatic Operation		
			SCHISCHEK Electrical ATEX		

**Ruskin Air Management Limited
is a ISO 9001 and 14001 registered
company.**

The statements made in this brochure or by our representatives in consequence of any enquiries arising out of this document are given for information purposes only. They are not intended to have any legal effect and the company is not to be regarded as bound thereby. The company will only accept obligations which are expressly negotiated for and agreed and incorporated into a written agreement made with its customers.

Due to a policy of continuous product development the specification and details contained herein are subject to alteration without prior notice.

**Comprehensive and detailed information
is available for all Actionair products.
Visit our website at www.actionair.co.uk**

Ruskin Air Management Limited



South Street, Whitstable, Kent
CT5 3DU England.

Tel: [REDACTED]

Fax: [REDACTED]

Email: sales@actionair.co.uk

Website: www.actionair.co.uk

actionair

Dampers Controls Fancoils