



Image with flexible flange 90.1045



SERIE 66

THREAD SHAFT INCREMENTAL ENCODER FOR INDUSTRIAL APPLICATIONS

Equivalent for SIEMENS 1XP8001-1 / 1XP8001-2

100% interchangeable (mechanically - electronically - pin out)

✓ 66-14121-1024.UC00 / 66-14122-1024.UC00

- Resolution up to 10000 pulses per turn
- External diameter 58 mm
- Thread shaft M8
- Protection class IP64 according to DIN EN 60529
- Anti-rotation system through flexible flange or anti-turn stick
- Connection by cable (other cable length available) or industrial connector M16

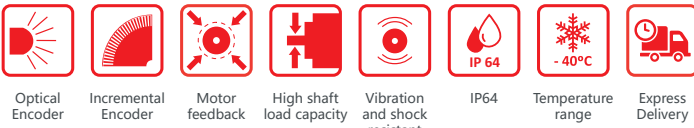

✓ Flexible flange (90.1045)

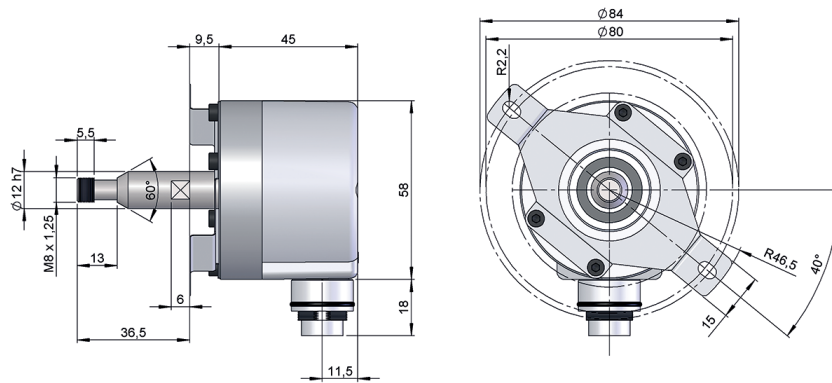

Drawing shaft type 1, anti-rotation system type 4, connection type 2

Flexible flange (90.1027)

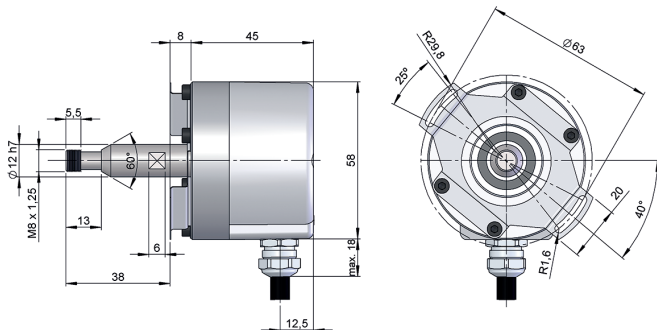

Drawing shaft type 1, anti-rotation system type 1, connection type 1

Anti-turn stick (90.1041)

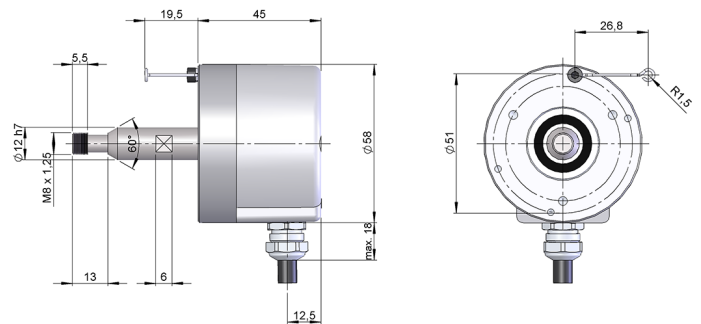

Drawing shaft type 1, anti-rotation system type 2, connection type 1



SERIE 66

THREAD SHAFT INCREMENTAL ENCODER FOR INDUSTRIAL APPLICATIONS

REFERENCE								Reference example: 66-14121-1024
Serie	Thread shaft	Anti-rotation system	Output signals	Connection	Power Supply / Electronic output	Pulses number	Special customer	
66 -	<input type="checkbox"/>	<input type="checkbox"/>	<input type="checkbox"/>	<input type="checkbox"/>	<input type="checkbox"/>	<input type="checkbox"/> <input type="checkbox"/> <input type="checkbox"/> <input type="checkbox"/> <input type="checkbox"/> <input type="checkbox"/>	<input type="checkbox"/> <input type="checkbox"/> <input type="checkbox"/> <input type="checkbox"/>	
	<input checked="" type="checkbox"/> 1. Thread M8	1. Option A Flexible flange 90.1027 2. Option B Anti-turn stick <input checked="" type="checkbox"/> 90.1041 4. Option C Flexible flange 90.1045 3. None (*)	<input checked="" type="checkbox"/> 1. ABZ, \overline{ABZ} 2. AB, \overline{AB}	<input checked="" type="checkbox"/> 1. Radial cable <input checked="" type="checkbox"/> 2. Radial M16 12p CW	0. 11...30 VDC / NPN Open collector 11...30 VDC <input checked="" type="checkbox"/> 1. 11...30 VDC / Line driver differential Push-Pull 11...30 VDC <input checked="" type="checkbox"/> 2. 5 VDC / RS422 5 VDC (compatible TTL) 6. 11...30 VDC / RS422 5 VDC (compatible TTL)		UT00. -40°C <input checked="" type="checkbox"/> UC00	

**Order your reference
Step file 3D**

info@encoderhohner.com
service available in 24 h

(*) Anti-rotation system type 1 (Flexible flange 90.1027) and 4 (Flexible flange 90.1045) supplied assembled.

Anti-rotation system type 2 (Anti-turn stick 90.1041) is supplied disassembled and includes the screws required for assembly.

Other required anti-rotation systems are not supplied assembled. All systems available in the sections "MOUNTING ACCESSORIES".

MECHANICAL SPECIFICATIONS

Materials	Cover: Aluminium Housing: Aluminium Shaft: Stainless Steel
Bearings	Ballraces
Bearings lifetime	1x10 ¹⁰ rev.
Housing fixing	Flexible flange 90.1027 (assembled) Flexible flange 90.1045 (assembled) Anti-turn stick 90.1041 (self-assembly kit included)
Permitted misalignment	±0.5 mm axial, ±0.3 mm radial (90.1027, 90.1045, 90.1041)
Maximum number of revolutions permitted mechanically	6000 rpm
Protection against dust and splashes according to DIN EN 60529	IP64
Rotor inertia moment	30 gcm ²
Starting torque at 20°C (68°F)	≤ 0.02 Nm
Maximum load permitted on axial shaft	40 N
Maximum load permitted on radial shaft	60 N
Weight aprox.	0.5 Kg
Operating temperature range	-20°C to +80°C - Standard -40°C to +80°C - Special Customer UT00
Vibration according to DIN EN 60068-2-6	100 m/s ² (10Hz...2000Hz)
Shock according to DIN EN 60068-2-27	1000 m/s ² (6ms)
Maximum pulses per turn	10000
Radial cable	2 meters cable or industrial connector M16 (other cable lengths available on order) Female connector not included

SERIE 66

THREAD SHAFT INCREMENTAL ENCODER FOR INDUSTRIAL APPLICATIONS

OUTPUT SIGNALS

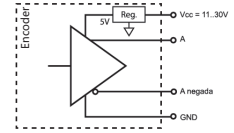
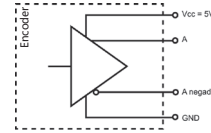
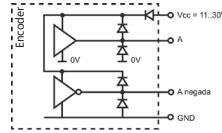
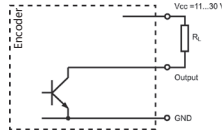

OUTPUT CIRCUIT	NPN Open Collector	Push-Pull Differential	RS422 (TTL compatible)	RS422 (TTL compatible)
Reference code	0	1	2	6
Power supply	11...30 VDC	11...30 VDC	5 VDC ±10%	11...30 VDC
Output voltage	11...30 VDC	11...30 VDC	5 VDC	5 VDC
Consumption	40 mA	Typical: 45 mA Max: 150 mA	Typical: 70 mA Max: 150 mA	Typical: 80 mA Max: 160 mA
Max. load capability / channel	40 mA	±30 mA	±20 mA	±20 mA
Length of cable allowed	50 m (24 VDC)	100 m	1200 m	1200 m
“Low” signal level	VOL < 0.4 VDC (24 VDC)	VOL < 2.5 VDC	VOL < 0.5 VDC	VOL < 0.5 VDC
“High” signal level	VOH > 2.2 VDC (24 VDC)	VOH > VCC – 3 VDC	VOH > 2.5 VDC	VOH > 2.5 VDC
Frequency	100 kHz	200 kHz	300 kHz	300 kHz
Short circuit protection	Not permanent	Yes	Yes	Yes
Protection polarity inversion	Yes	Yes	Not permanent	Yes

Channel B leads (90° electric) channel A, view from the shaft, shaft rotating clockwise

CONNECTION



	Cable 3x2x0.14+2x0.34 95.0008003	Connector <input checked="" type="checkbox"/> M16 12p CW
GND	Black (BK)	K - L
+UB	Red (RD)	B - M
A	Yellow (YE)	E
B	Green (GN)	H
\bar{A}	Brown (BN)	F
\bar{B}	Blue (BU)	A
Z	Grey (GY)	C
\bar{Z}	Orange (OG)	D
Case	Shield	Case

SERIE 66

THREAD SHAFT INCREMENTAL ENCODER FOR INDUSTRIAL APPLICATIONS

ACCESSORIES EXAMPLES

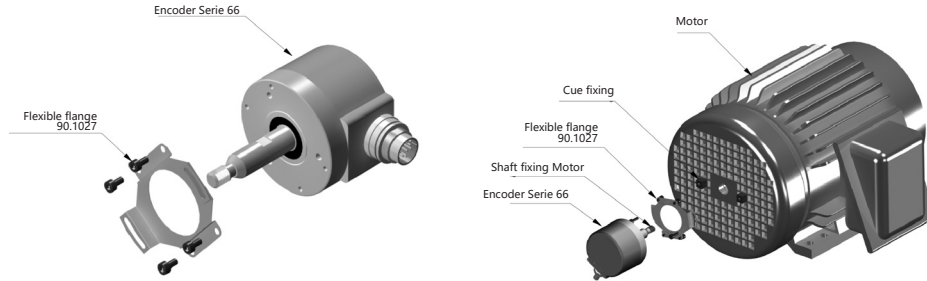

All the accessories available in the section "MOUNTING ACCESSORIES".

CONNECTION DIMENSIONS

Female connector not included

Connection 2

Radial
M16 12p
male panel
clockwise

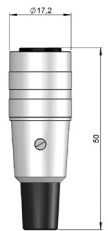
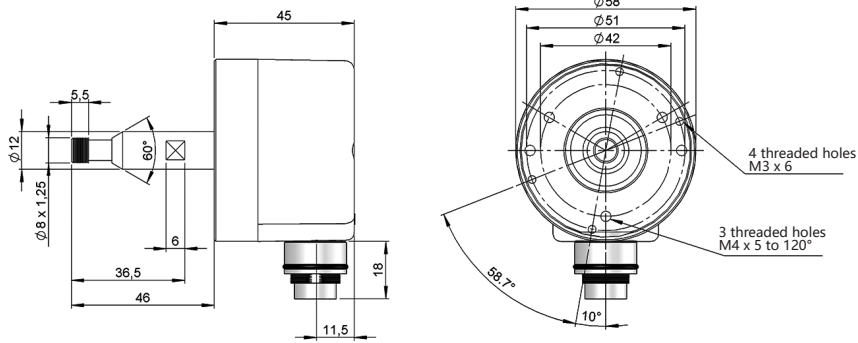

Female connector
95.0007149



Pre-assembled cable
89.036.010.051.XX
Length in meters