

# Solenoid valves VUVB/valve terminals VTUB

**FESTO**

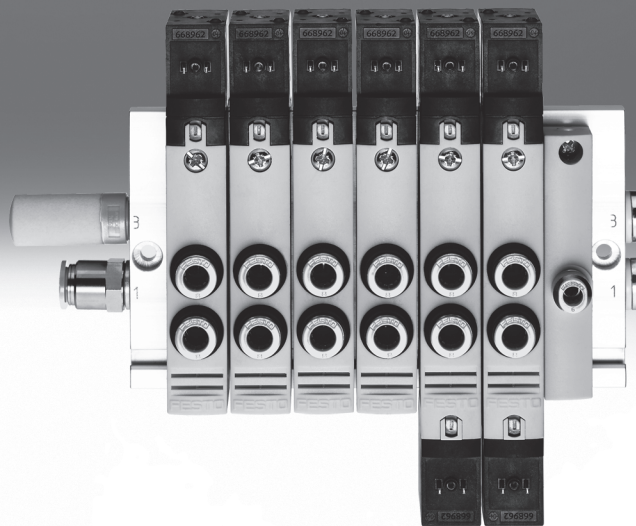

# Solenoid valves VUVB/valve terminals VTUB

Key features

FESTO

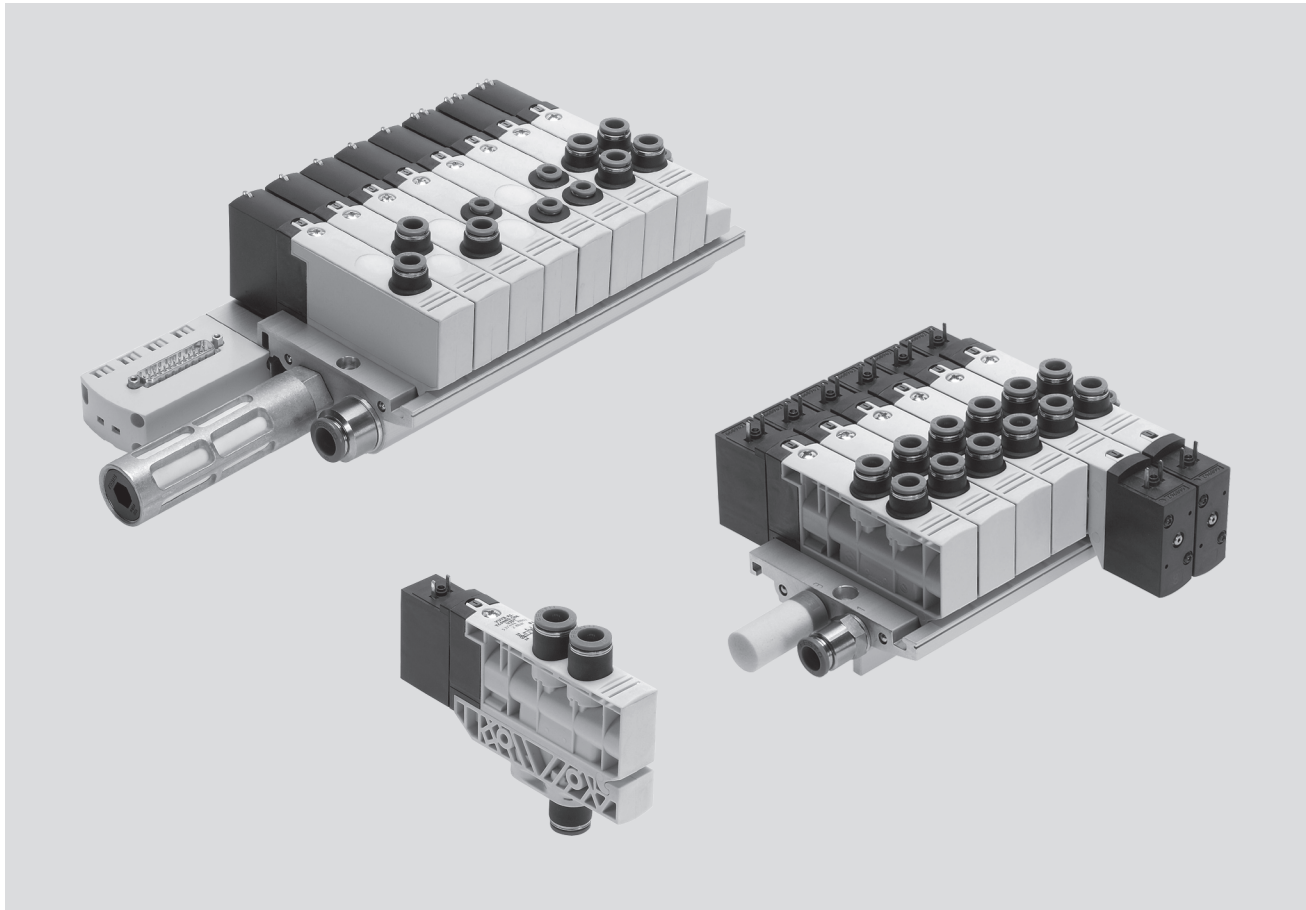

## Innovative

- Valve terminal for a wide range of pneumatic applications
- Standardised from the individual valve to the multi-pin plug
- Great flexibility during planning, assembly and operation
- Selectable valve functions; 3/2 and 4/2-way function also suitable for vacuum applications
- Wide selection of optimally tailored accessories for flow rates from 200 to 1,000 l/min

## Versatile

- Room for expansion with 2 ... 16 valve positions on one valve terminal
- Use of individual valves in combination with an individual sub-base
- Flexibility of the pneumatic working lines provides a practical solution to different requirements
- Two pressure zones (additional zones on request)
- Large pressure range -0.9 ... 8 bar
- Extensive operating voltage range from 12 V DC to 230 V AC

## Reliable

- Manual override
- Durable thanks to tried-and-tested piston spool valves
- Sturdy thanks to the polymer housing and metal manifold rail
- Fast troubleshooting thanks to an LED signal status display in the plug socket with cable or on the valve in the case of the design with multi-pin plug

## Easy to mount

- Ready-to-install and tested unit
- Lower ordering, installation and commissioning costs
- Secure mounting on wall or H-rail

 Note

Valve terminals are available for 4, 6, 8, 10, 12 and 16 valve positions in connection size G $\frac{1}{2}$ . On the version

with 16 valve positions, only single solenoid valves can be mounted from the ninth valve position onwards.

# Solenoid valves VUVB/valve terminals VTUB

Key features

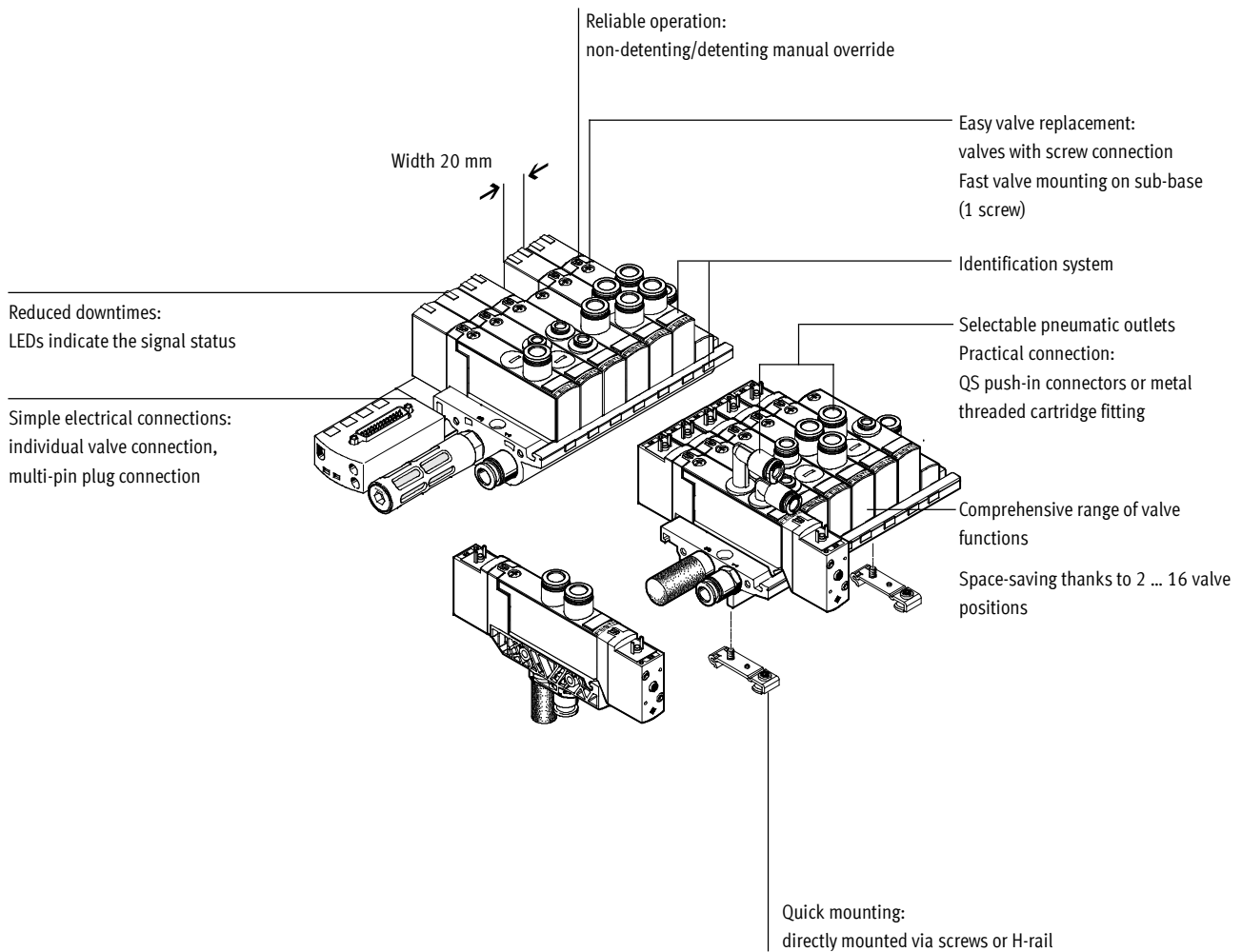

## Equipment options

### Valve functions

- 3/2-way valve, normally open
- 3/2-way valve, normally closed
- 4/2-way valve, single solenoid
- 4/2-way valve, double solenoid

### Electrical connection options

#### Individual connection/individual valve connection

- 2 ... 16 valve positions with manifold rail
- 2 ... 32 solenoid coils
- Via plug socket with cable with either LED or illuminating seal

#### Multi-pin plug

- 4 ... 16 valve positions/  
max. 24 solenoid coils
- Sub-D

## Valve terminal configurator

A valve terminal configurator is available to help you select a suitable valve terminal VTUB. This makes it much easier to order the right product. Valve terminals VTUB are

ordered via an ident. code. All valve terminals are supplied fully assembled and individually tested. This reduces assembly and installation time to a minimum.

Ordering system for valve terminal VTUB

- Individual electrical connection
  - Electrical multi-pin plug connection
- ➔ Internet: vtub

Download CAD data ➔ [www.festo.com](http://www.festo.com)

# Solenoid valves VUVB/valve terminals VTUB

Key features

## Pilot air supply module

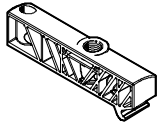

The pilot air supply module is included in the scope of delivery of the manifold rail.

The pilot air supply module for internal or external pilot air supply ensures even greater flexibility.

## Manifold rail

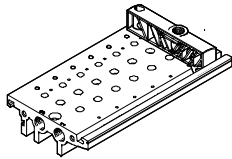

The manifold rail features a groove into which the semi in-line valves are latched and secured with just one screw.

The valve functions 4/2-way single solenoid, 4/2-way double solenoid, 3/2-way normally closed and 3/2-way normally open are available. All semi in-line valves can be supplied with cartridges QSP for tubing

diameters 4, 6, 8 and 10. 4/2-way valves are also supplied without cartridges, allowing users to fit cartridges of their choice or blanking plugs.

## Pressure zone supply module

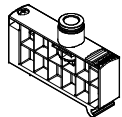

The pressure zone supply module occupies one valve position and can

be used as an additional supply or for supplying a pressure zone.

## Individual valve

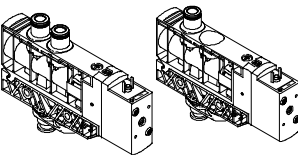

An individual valve can be ordered as an in-line valve (comprising semi in-line valve and sub-base ready assembled) in all functions. Tubing

diameters 6 and 8 can be selected here. The in-line valve, however, can also be assembled using an individual

sub-base and semi in-line valve. All tubing diameters and the variant without cartridge are available in this case.

## Blanking plate

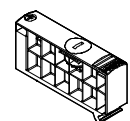
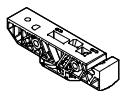

Plate without valve function for reserving valve positions on a valve terminal.

Valves and blanking plates are attached to the manifold rail using one screw.

## Sub-base



Individual sub-bases can be equipped with any valve.

Electrical connection is by means of a standardised connector plug, square design to EN 175301-803, type C.

Pre-assembled plug sockets with cable or plugs for self-assembly are offered for this.

# Solenoid valves VUVB/valve terminals VTUB

Key features – Pneumatic components

FESTO

## Pneumatic connection

### Supply and exhaust

The valves are supplied pneumatically via manifold rails or individual sub-bases.

The manifold rails contain common lines for compressed air supply, exhaust and pilot exhaust for all valves.

The common lines can be connected

- at the left (code L),
- at the right (code R) or
- at both ends (no code).

## Pilot air supply

In-line valves are available with internal and external pilot air supply. With semi in-line valves the mounting position of the insert in the sub-base determines whether the valves are actuated internally or externally.

### Internal pilot air supply

Internal pilot air supply can be selected if the supply pressure is between 2 and 8 bar. The pilot air supply is branched from duct 1 in the pressure zone supply module in this case.

If the selector is installed as shown in position **1**, it means that the pilot air supply will be branched internally from duct 1.

### External pilot air supply

External pilot air supply must be used if the supply pressure is between  $-0.9$  and  $+2$  bar. The pilot air supply is supplied via port 12/14 of the pressure zone supply module in this case.

If the selector is turned  $180^\circ$  and installed as shown in position **2**, it means that the valve manifold is set to external pilot air supply.

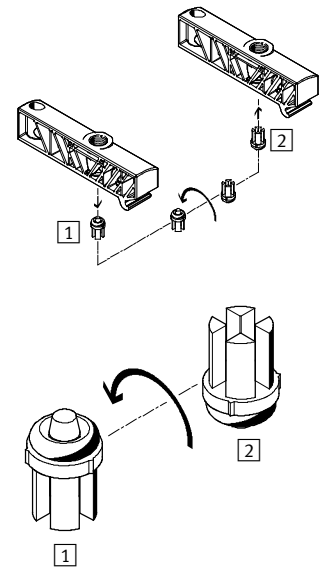

# Solenoid valves VUVB/valve terminals VTUB

Product range overview – Individual valves and manifold valves

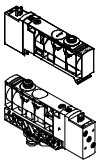
Function	Version	Type	Nominal flow rate [l/min]	Pneumatic connection	Operating voltage [V]	Semi in-line valve	In-line valve	Pilot air supply		→ Page/ Internet
								Internal	External	
3/2-way valves	Single solenoid valve for individual connection and valve manifold									
		VUVB-...-M32-...	200	QS-4	24 DC 110 AC 230 AC 12 DC/24 AC	■	-	-	■	14
			500	QS-6		■	■	■	■	
			800	QS-8		■	■	■	■	
			1,000	QS-10		■	-	-	■	
			1,000	QX <sup>1)</sup>		■	-	-	■	

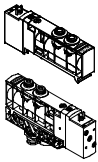
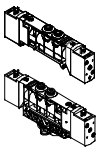

Function	Version	Type	Nominal flow rate [l/min]	Pneumatic connection	Operating voltage [V]	Semi in-line valve	In-line valve	Pilot air supply		→ Page/ Internet	
								Internal	External		
4/2-way valves	Single solenoid valve for individual connection and valve manifold										
		VUVB-...-M42-...	200	QS-4	24 DC 110 AC 230 AC 12 DC/24 AC	■	-	-	■	14	
			500	QS-6		■	■	■	■		
			800	QS-8		■	■	■	■		
			1,000	QS-10		■	-	-	■		
			1,000	QX <sup>1)</sup>		■	-	-	■		
	Double solenoid valve for individual connection and valve manifold										
		VUVB-...-B42-...	200	QS-4	24 DC 110 AC 230 AC 12 DC/24 AC	■	-	-	■	14	
			500	QS-6		■	■	■	■		
			800	QS-8		■	■	■	■		
			1,000	QS-10		■	-	-	■		
1,000			QX <sup>1)</sup>	■		-	-	■			

1) Cartridge not included

# Solenoid valves VUVB/valve terminals VTUB

Product range overview – Terminal valves

Function	Version	Type	Nominal flow rate [l/min]	Pneumatic connection	Operating voltage [V]	Semi in-line valve	Pilot air supply External	→ Page/Internet
3/2-way valves	Single solenoid valve for valve terminal with electrical multi-pin plug connection							
		VUVB-...-M32-...	200	QS-4	24 DC	<input type="checkbox"/>	<input type="checkbox"/>	35
			500	QS-6		<input type="checkbox"/>	<input type="checkbox"/>	
			800	QS-8		<input type="checkbox"/>	<input type="checkbox"/>	
			1,000	QS-10		<input type="checkbox"/>	<input type="checkbox"/>	
			1,000	QX <sup>1)</sup>		<input type="checkbox"/>	<input type="checkbox"/>	

Function	Version	Type	Nominal flow rate [l/min]	Pneumatic connection	Operating voltage [V]	Semi in-line valve	Pilot air supply External	→ Page/Internet
4/2-way valves	Single solenoid valve for valve terminal with electrical multi-pin plug connection							
		VUVB-...-M42-...	200	QS-4	24 DC	<input type="checkbox"/>	<input type="checkbox"/>	35
			500	QS-6		<input type="checkbox"/>	<input type="checkbox"/>	
			800	QS-8		<input type="checkbox"/>	<input type="checkbox"/>	
			1,000	QS-10		<input type="checkbox"/>	<input type="checkbox"/>	
			1,000	QX <sup>1)</sup>		<input type="checkbox"/>	<input type="checkbox"/>	
	Double solenoid valve for valve terminal with electrical multi-pin plug connection							
		VUVB-...-B42-...	200	QS-4	24 DC	<input type="checkbox"/>	<input type="checkbox"/>	35
			500	QS-6		<input type="checkbox"/>	<input type="checkbox"/>	
			800	QS-8		<input type="checkbox"/>	<input type="checkbox"/>	
			1,000	QS-10		<input type="checkbox"/>	<input type="checkbox"/>	
1,000			QX <sup>1)</sup>	<input type="checkbox"/>		<input type="checkbox"/>		

1) Cartridge not included

# Solenoid valves VUVB/valve terminals VTUB

Product range overview

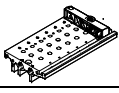
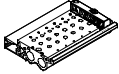
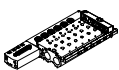
Function	Version	Type	Pneumatic connection	Valve positions													Pilot air supply		→ Page/ Internet
				2	3	4	5	6	7	8	9	10	11	12	16	Internal	External		
Manifold rail	For valve manifold with individual electrical connection																		
		VABM	G $\frac{1}{4}$	■	■	■	■	■	■	■	■	■	■	■	■	-	■	■	23
		VABM	G $\frac{1}{2}$	■	■	■	■	■	■	■	■	■	■	■	■	■	■	■	■
Manifold rail	For valve terminal with electrical multi-pin plug connection																		
		VABM-...-M1	G $\frac{1}{2}$	-	-	■	-	■	-	■	-	■	-	■	■	■	■	■	41

Function	Version	Type	Pilot air supply		→ Page/ Internet
			Internal	External	
Sub-base	Individual valve				
	VABS		■	■	25

Function	Version	Type	Pneumatic connection	Use	→ Page/ Internet
Pressure zone supply module		VABF	QS-10	For additional supply to the manifold rail	43

Function	Version	Type	Use	→ Page/ Internet
Blanking plate		VABB	For covering vacant positions	44

Function	Version	Type	Use	→ Page/ Internet
Separator		VABD	For duct separation	44

Function	Version	Type	Use	→ Page/ Internet
H-rail mounting kit		VAME	For mounting on the H-rail NRH-35-2000	49

Function	Version	Type	Use	→ Page/ Internet
Cartridge		QSP...		48

Function	Version	Type	Use	→ Page/ Internet
Adapter		NPFA		49

# Solenoid valves VUVB

Peripherals overview

## Overview – Solenoid valve VUVB

Individual position with individual electrical connection

These peripherals are ordered via individual parts/accessories.

An individual valve can be ordered as an in-line valve or as a fully assembled semi in-line valve on a sub-base.

The in-line valve is available with 6 or 8 mm push-in connectors. The semi in-line valve on sub-base is available

with 4, 6, 8 or 10 mm push-in connectors or as a variant without cartridge.

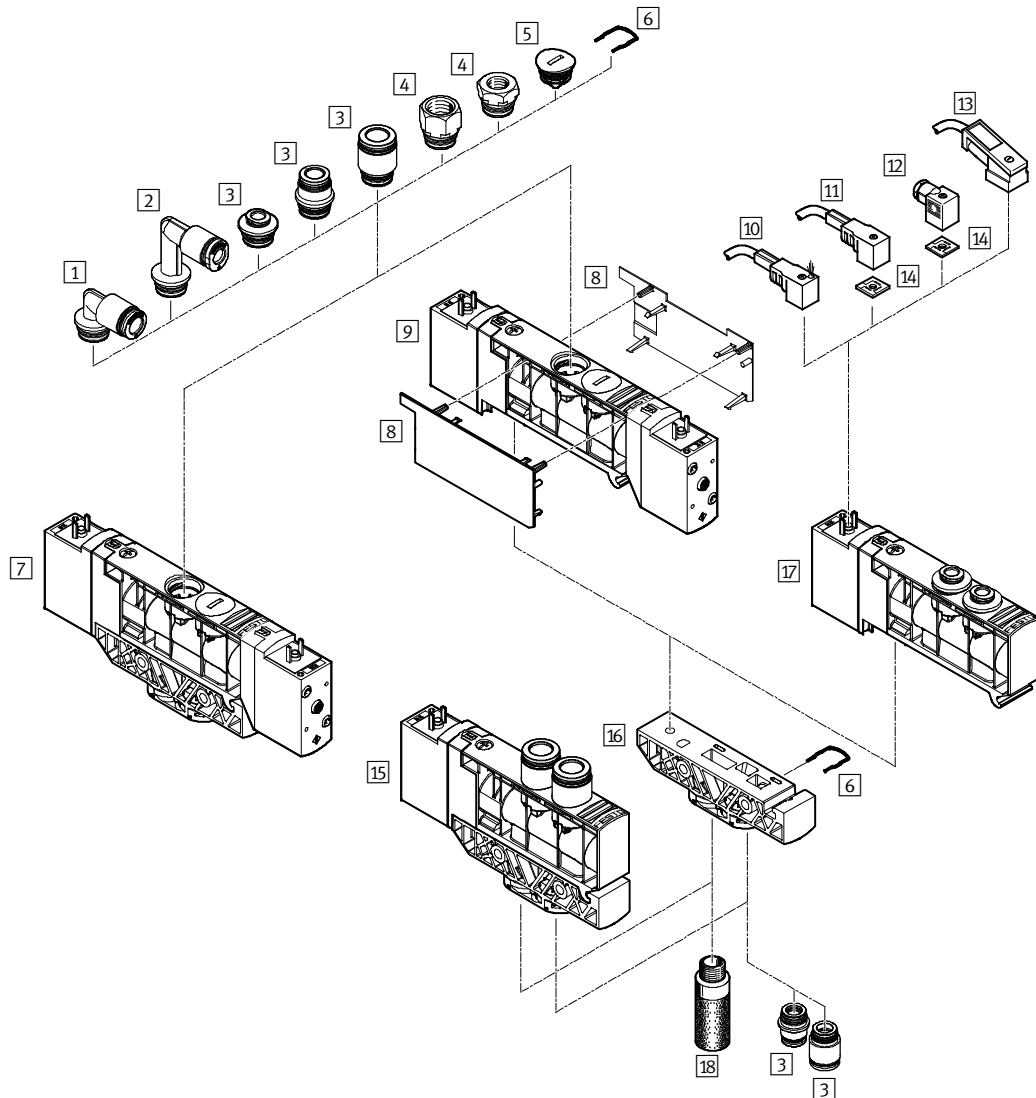

# Solenoid valves VUVB

Peripherals overview

**FESTO**

Accessories		
	Brief description	→ Page/Internet
1	Cartridge QSPL	For connecting compressed air tubing with standard O.D.
2	Cartridge QSPLL	For connecting compressed air tubing with standard O.D.
3	Cartridge QSP	For connecting compressed air tubing with standard O.D.
4	Adapter NPFA	–
5	Blanking plug QSPC18	For sealing the pneumatic connections on the valve
6	Clamping spring	For fitting cartridges and blanking plugs (included in the scope of delivery of the cartridge QSP... and the blanking plug QSPC18)
7	Double solenoid valve VUVB-L-...-B-...	In-line valve
8	Cover for valve housing VAMC	–
9	Double solenoid valve VUVB-S-...-B-...	Semi in-line valve
10	Plug socket with cable with LED KMEB-1-...-LED	For indicating the signal status
11	Plug socket with cable KMEB-1-230AC-...	Can be used up to 230 V
12	Plug socket MSSD-EB	–
13	Plug socket with cable with LED KMEB-2-24-...	For indicating the signal status
14	Illuminating seal MEB-LD	For indicating the signal status
15	Single solenoid valve VUVB-L-...-M-...	In-line valve
16	Sub-base VABS-B6-PB-...	For individual valve
17	Single solenoid valve VUVB-S-...-M-...	Semi in-line valve
18	Silencer U, UC	For fitting in exhaust ports

# Solenoid valves VUVB

Peripherals overview

## Overview – Solenoid valve VUVB

Manifold assembly/valve terminal with individual electrical connections

- "Individual connection type" code: ET  
Valve terminals with individual electrical connections are available in gradations from 2 to max. 16 valve positions.
- Valve positions can either be fitted with a valve or a blanking plate for future expansions.
- In total up to 32 solenoid valves can be actuated.

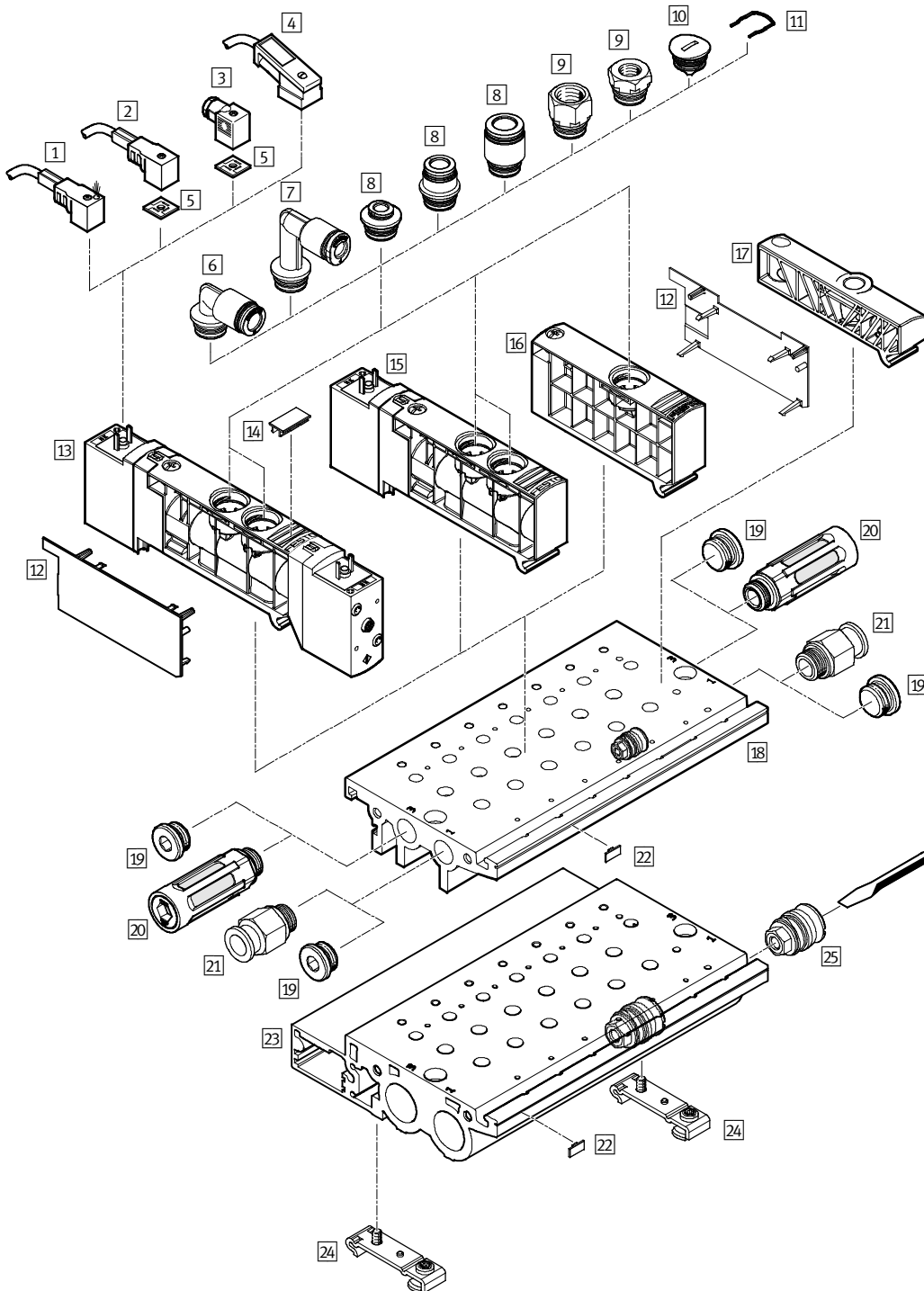

# Solenoid valves VUVB

Peripherals overview

FESTO

Accessories		
	Brief description	→ Page/Internet
1	Plug socket with cable with LED KMEB-1-...-LED	For indicating the signal status 50
2	Plug socket with cable KMEB-1-230AC-...	Can be used up to 230 V 50
3	Plug socket MSSD-EB	– 50
4	Plug socket with cable with LED KMEB-2-24-...	For indicating the signal status 50
5	Illuminating seal MEB-LD	For indicating the signal status 50
6	Cartridge QSPL-...	For connecting compressed air tubing with standard O.D. 48
7	Cartridge QSPLL-...	For connecting compressed air tubing with standard O.D. 48
8	Cartridge QSP-...	For connecting compressed air tubing with standard O.D. 48
9	Adapter NPFA-...	– 49
10	Blanking plug QSPC18	For sealing the pneumatic connections on the valve 49
11	Clamping spring	For fitting cartridges and blanking plugs (included in the scope of delivery of the cartridge QSP... and the blanking plug QSPC18) –
12	Cover for valve housing VAMC	– 46
13	Double solenoid valve VUVB-...-B	– 20
14	Inscription label IBS-9x17	For identifying the valves 49
15	Single solenoid valve VUVB-...-M	– 20
16	Blanking plate/pressure zone supply module VABF/VABB	Pressure zone supply module VABF: with cartridge Blanking plate VABB: for vacant position, with blanking plug 43/44
17	Pilot air supply module	For pilot air supply (included in the scope of delivery of the manifold rail VABM) –
18	Manifold rail VABM-B6-E-G14-...	Pneumatic connection G $\frac{1}{4}$ , for connecting max. 12 valves 23
19	Blanking plug B	– 49
20	Silencer U, UC	For fitting in exhaust ports 49
21	Push-in fitting QS	For connecting compressed air tubing with standard O.D. 48
22	Inscription label MH-BZ-80X	For identifying the manifold rail 49
23	Manifold rail VABM-B6-E-G12-...	Pneumatic connection G $\frac{1}{2}$ , for connecting max. 16 valves 24
24	H-rail mounting kit VAME	For mounting on the H-rail NRH-35-2000 49
25	Separator for pressure zones VABD	For mounting in the manifold rail 44



# Solenoid valves VUVB

Type codes – Individual valves and manifold valves

		VUVB	-	L	-	M32C	-	A	Z	D	-	Q6	-	1	C1
<b>Valve series</b>															
VUVB	Solenoid valve														
<b>Design</b>															
L	In-line valve														
S	Semi in-line valve														
<b>Valve function</b>															
M32C	3/2-way valve, normally closed														
M32U	3/2-way valve, normally open														
M42	4/2-way valve, single solenoid														
B42	4/2-way valve, double solenoid														
<b>Reset method</b>															
-	None (double solenoid)														
A	Pneumatic reset														
<b>Pilot air supply</b>															
-	Internal														
Z	External														
<b>Manual override</b>															
D	Non-detenting/detenting														
<b>Pneumatic connection</b>															
Q4	For tubing O.D. 4 mm														
Q6	For tubing O.D. 6 mm														
Q8	For tubing O.D. 8 mm														
Q10	For tubing O.D. 10 mm														
QX	Without push-in connector														
<b>Operating voltage</b>															
1	24 V DC														
2A	110 V AC														
3A	230 V AC														
5W	12 V DC/24 V AC														
<b>Electrical connection</b>															
C1	Plug socket connection pattern to EN 175301-803, type C														

# Solenoid valves VUVB

Technical data – Individual valves and manifold valves

-  Voltage  
12, 24 V DC  
24, 110, 230 V AC
-  Pressure  
-0.9 ... +8 bar
-  Temperature range  
-5 ... +50 °C

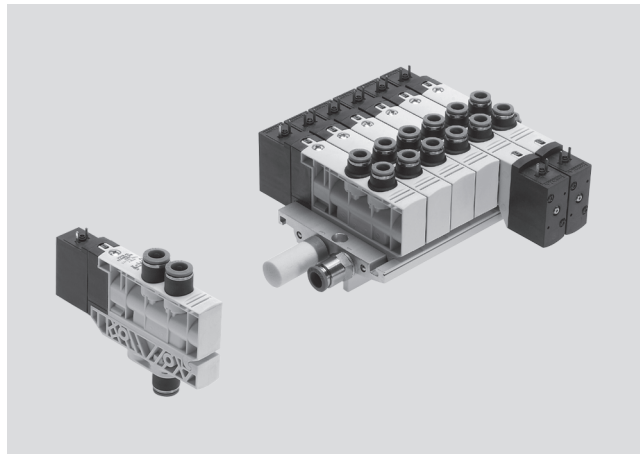

General technical data					
Valve function		3/2-way, single solenoid	4/2-way, single solenoid	4/2-way, double solenoid	
Design	Piston spool valve				
Sealing principle	Soft				
Actuation type	Electric				
Reset method	Pneumatic spring			-	
Type of control	Piloted				
Pilot air supply	Internal or external				
Direction of flow	Non-reversible				
Exhaust function	No flow control				
Manual override	Non-detenting, detenting				
Type of mounting	Via through-hole				
Mounting position	Any				
Nominal size	[mm]	7			
Standard nominal flow rate	qnN	[l/min]	200 (QS-4); 500 (QS-6); 800 (QS-8); 1,000 (QS-10)		
Width	[mm]	20			
Product weight	In-line valve	[g]	170	170	240
	Semi in-line valve	[g]	150	150	220

Operating and environmental conditions	
Operating medium	Compressed air in accordance with ISO 8573-1:2010 [7:4:4]
Note on operating/pilot medium	Operation with lubricated medium possible (in which case lubricated operation will always be required)
Operating pressure	[bar] -0.9 ... +8
Operating pressure for valve terminal with internal pilot air supply	[bar] 2 ... 8
Pilot pressure	[bar] 2 ... 8
Ambient temperature	[°C] -5 ... +50
Temperature of medium	[°C] -5 ... +50
Corrosion resistance class CRC	1 <sup>1)</sup>
Note on materials	RoHS-compliant
CE mark	To EU Low Voltage Directive

1) Corrosion resistance class 1 according to Festo standard 940 070  
Components subject to low corrosion stress. Transport and storage protection. Parts that do not have primarily decorative surface requirements, e.g. in internal areas that are not visible or behind covers.

-  - Note  
A filter must be installed upstream of valves operated in vacuum mode. This prevents any foreign matter in the intake air getting into the valve (e.g. when operating a suction cup).

# Solenoid valves VUVB

Technical data – Individual valves and manifold valves

Electrical data			
Electrical connection		Plug, square design to EN 175301-803, type C	
Nominal operating voltage	DC	[V]	12, 24
	AC	[V]	24, 110, 230
Permissible voltage fluctuations		[%]	±10
Electrical power consumption	12 V DC	[W]	1.4
	24 V DC	[W]	1.5
	24 V AC	[VA]	Pull: 3.1, hold: 2.2
	110 V AC	[VA]	Pull: 3.1, hold: 2.2
	230 V AC	[VA]	Pull: 3.1, hold: 2.2
Protection class to EN 60529		IP65 (in combination with plug socket)	

Valve switching times [ms]			
Valve function	3/2-way, single solenoid	4/2-way, single solenoid	4/2-way, double solenoid
On	20	20	–
Off	20	20	–
Changeover	–	–	15

### Pilot pressure p2 as a function of working pressure p1

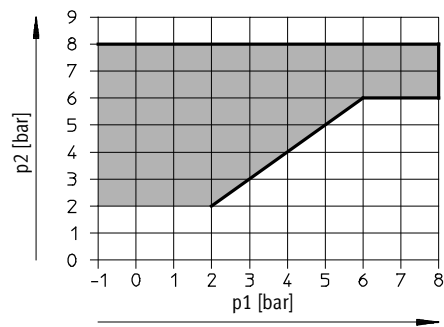

### Materials

Sectional view – Single solenoid valve

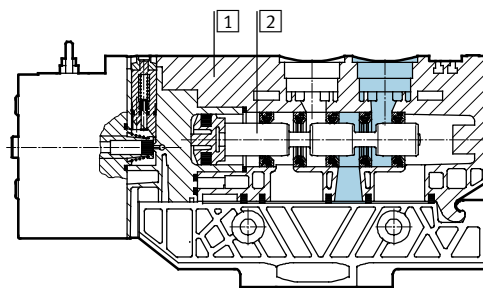

Sectional view – Double solenoid valve

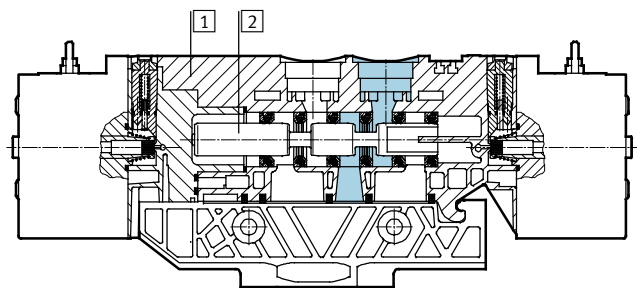

1	Housing	Reinforced polyamide
2	Piston spool	Wrought aluminium alloy
–	Seals	Nitrile rubber, hydrogenated nitrile rubber, fluoro elastomer

# Solenoid valves VUVB

Technical data – Individual valves and manifold valves



**Dimensions – 3/2-way and 4/2-way valve, single solenoid** Download CAD data → [www.festo.com](http://www.festo.com)  
 In-line valve

- 1 Manual override
- 2 Fitting QS-6 or QS-8
- 3 Through-hole for screw M4
- 4 Plug socket connection pattern to EN 175301-803, type C

Type	B1	D1	H1	H2	L1	L2	L3	L4	L5	L6	L7
VUVB-L-M32-Q6	20	G1/4	83.1	16.5	129	63.2	40	14	80.8	71	21
VUVB-L-M32-Q8			89.9								

**Dimensions – 3/2-way and 4/2-way valve, single solenoid** Download CAD data → [www.festo.com](http://www.festo.com)  
 Semi in-line valve

- 1 Manual override
- 2 Fitting QS-
- 4 Plug socket connection pattern to EN 175301-803, type C

Type	B1	D1	H1	H2	L1	L2	L3	L4
VUVB-S-M32...-Q4	20	M4	57	53.9	129	44.3	80.8	14
VUVB-S-M32...-Q6			60					
VUVB-S-M32...-Q8			63					
VUVB-S-M32...-Q10			65					

# Solenoid valves VUVB

Technical data – Individual valves and manifold valves



## Dimensions – 4/2-way valve, double solenoid

Download CAD data → [www.festo.com](http://www.festo.com)

In-line valve

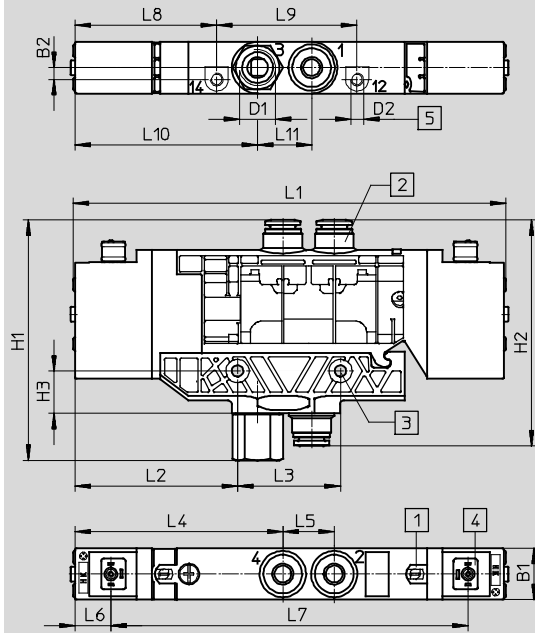

- 1 Manual override
- 2 Fitting QS-6 or QS-8
- 3 Through-hole for screw M4
- 4 Plug socket connection pattern to EN 175301-803, type C
- 5 Port for external pilot air

Type	B1	B2	D1	D2	H1	H2	L1	L2	L3	L4	L5	L6	L7	L8	L9	L10	L11
VUVB-L-B42--Q6	20	4.6	G $\frac{1}{4}$	M5	83.1	16.5	168.2	63.2	40	80.8	20	14	138.8	55.1	54.5	71	21
VUVB-L-B42--Q8					89.9												

## Dimensions – 4/2-way valve, double solenoid

Download CAD data → [www.festo.com](http://www.festo.com)

Semi in-line valve

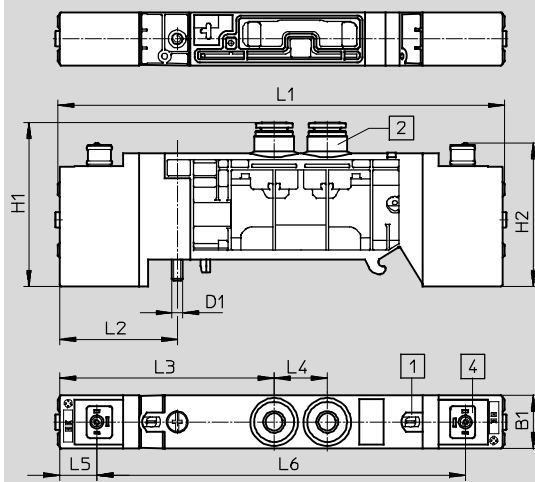

- 1 Manual override
- 2 Fitting QS
- 4 Plug socket connection pattern to EN 175301-803, type C

Type	B1	D1	H1	H2	L1	L2	L3	L4	L5	L6
VUVB-S-B42...-Q4	20	M4	57	53.9	168.2	44.3	80.8	20	14	138.8
VUVB-S-B42...-Q6			60							
VUVB-S-B42...-Q8			63							
VUVB-S-B42...-Q10			65							

# Solenoid valves VUVB

Technical data – Individual valves and manifold valves



## Dimensions – Manifold assembly

Download CAD data → [www.festo.com](http://www.festo.com)

Manifold rail G $\frac{3}{4}$

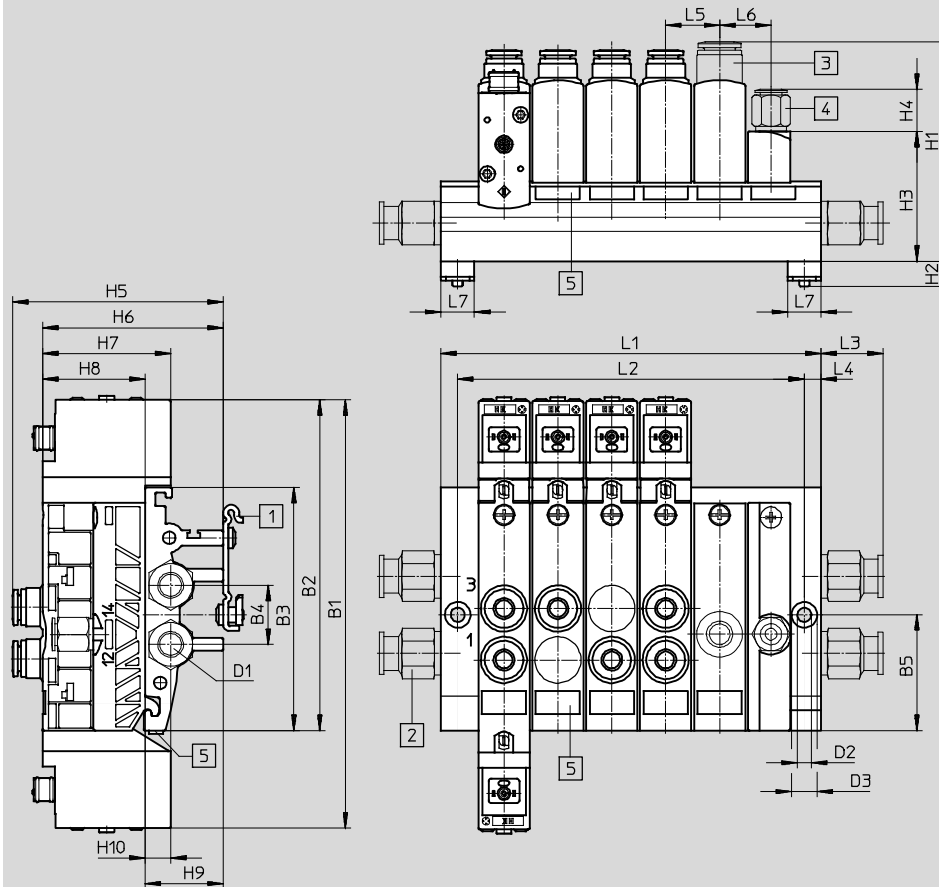

- 1 Attachment for mounting rail NRH-35-2000 (optional)
- 2 Push-in fittings (optional)
- 3 Cartridge (optional, only with pressure zone supply module)
- 4 Push-in fitting (optional)
- 5 Inscription label (optional)

Type	B1	B2	B3	B4	B5	D1	D2 H13	D3 H13	H1	H2	H3	H4	H6	H7	H8	H9	H10	L1 ±0.1	L2 ±0.1	L3	L4	L5	L6	L7
VTUB-2	166.8	128.3	94.7	23	45	G $\frac{3}{4}$	5.5	10	88.4	10	50.5	16.4	70.5	50.1	40	31	10	85	72	24.1	6.5	21	20	13
VTUB-3																		106	93					
VTUB-4																		127	114					
VTUB-5																		148	135					
VTUB-6																		169	156					
VTUB-7																		190	177					
VTUB-8																		211	198					
VTUB-9																		232	219					
VTUB-10																		253	240					
VTUB-11																		274	261					
VTUB-12																		295	282					

Type	H5
QSPK-18-4	74.6
QSPK-18-6	74.7
QSPK-18-8	81.7
QSPK-18-10	85.5

# Solenoid valves VUVB

Technical data – Individual valves and manifold valves



## Dimensions – Manifold assembly

Download CAD data → [www.festo.com](http://www.festo.com)

Manifold rail G $\frac{1}{2}$

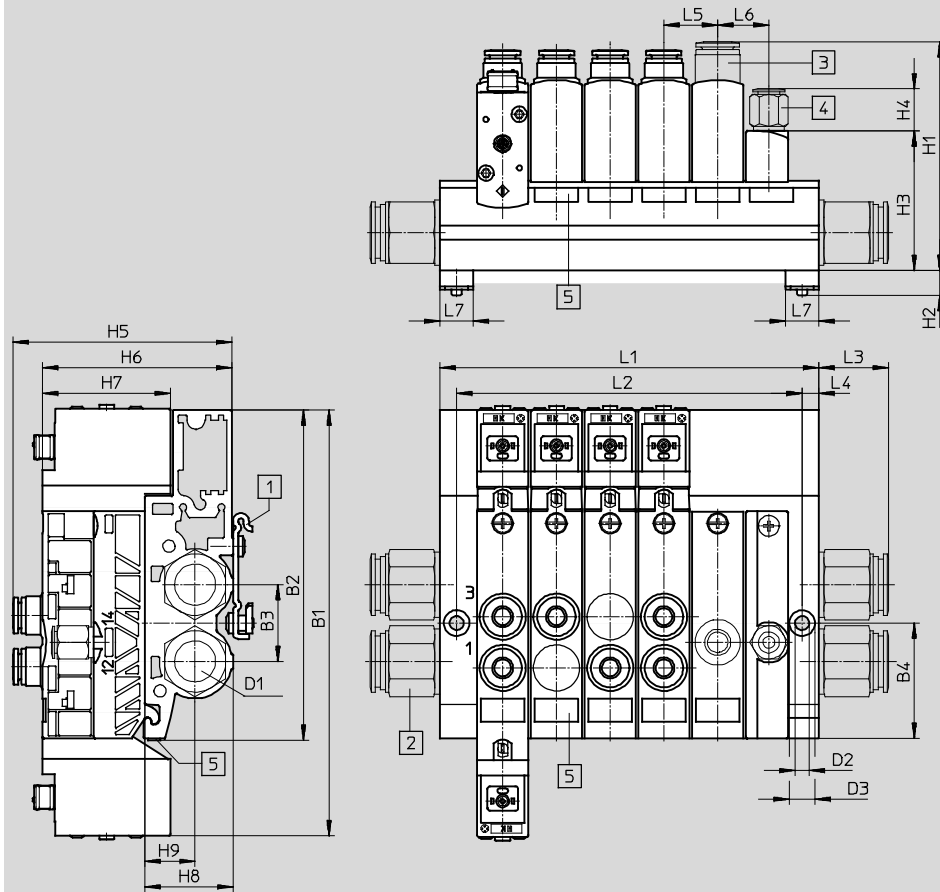

1 Attachment for mounting rail NRH-35-2000 (optional)

2 Push-in fittings (optional)

3 Cartridge (optional, only with pressure zone supply module)

4 Push-in fitting (optional)

5 Inscription label (optional)

Type	B1	B2	B3	B4	D1	D2 H13	D3 H13	H1	H2	H3	H4	H6	H7	H8	H9	L1 ±0.1	L2 ±0.1	L3	L4	L5	L6	L7
VTUB-2	166.8	129.1	30	45	G $\frac{1}{2}$	5.5	10	89.4	10	54.5	16.4	74	50.1	34.5	19.7	85	72	27.35	6.5	21	20	13
VTUB-3																106	93					
VTUB-4																127	114					
VTUB-5																148	135					
VTUB-6																169	156					
VTUB-7																190	177					
VTUB-8																211	198					
VTUB-9																232	219					
VTUB-10																253	240					
VTUB-11																274	261					
VTUB-12																295	282					

Type	H5
QSPK18-4	78.6
QSPK18-6	78.7
QSPK18-8	85.7
QSPK18-10	89.5

# Solenoid valves VUVB

Technical data – Individual valves and manifold valves

Ordering data – In-line valves						
Circuit symbol	Code	Description	Voltage	Pneumatic connection	Part No.	Type
<b>3/2-way valves</b>						
	–	Normally closed, internal pilot air supply, pneumatic spring return	24 V DC	QS-6	537468	VUVB-L-M32C-AD-Q6-1C1
				QS-8	537469	VUVB-L-M32C-AD-Q8-1C1
			110 V AC	QS-6	537538	VUVB-L-M32C-AD-Q6-2AC1
				QS-8	537539	VUVB-L-M32C-AD-Q8-2AC1
			230 V AC	QS-6	537546	VUVB-L-M32C-AD-Q6-3AC1
				QS-8	537547	VUVB-L-M32C-AD-Q8-3AC1
	–	Normally open, internal pilot air supply, pneumatic spring return	24 V DC	QS-6	537470	VUVB-L-M32U-AD-Q6-1C1
				QS-8	537471	VUVB-L-M32U-AD-Q8-1C1
			110 V AC	QS-6	537540	VUVB-L-M32U-AD-Q6-2AC1
				QS-8	537541	VUVB-L-M32U-AD-Q8-2AC1
			230 V AC	QS-6	537548	VUVB-L-M32U-AD-Q6-3AC1
				QS-8	537549	VUVB-L-M32U-AD-Q8-3AC1
	–	Normally closed, external pilot air supply, pneumatic spring return	24 V DC	QS-6	537476	VUVB-L-M32C-AZD-Q6-1C1
				QS-8	537477	VUVB-L-M32C-AZD-Q8-1C1
			110 V AC	QS-6	537554	VUVB-L-M32C-AZD-Q6-2AC1
				QS-8	537555	VUVB-L-M32C-AZD-Q8-2AC1
			230 V AC	QS-6	537562	VUVB-L-M32C-AZD-Q6-3AC1
				QS-8	537563	VUVB-L-M32C-AZD-Q8-3AC1
	–	Normally open, external pilot air supply, pneumatic spring return	24 V DC	QS-6	537478	VUVB-L-M32U-AZD-Q6-1C1
				QS-8	537479	VUVB-L-M32U-AZD-Q8-1C1
			110 V AC	QS-6	537556	VUVB-L-M32U-AZD-Q6-2AC1
				QS-8	537557	VUVB-L-M32U-AZD-Q8-2AC1
			230 V AC	QS-6	537564	VUVB-L-M32U-AZD-Q6-3AC1
				QS-8	537565	VUVB-L-M32U-AZD-Q8-3AC1
<b>4/2-way valves</b>						
	–	Single solenoid, internal pilot air supply, pneumatic spring return	24 V DC	QS-6	537472	VUVB-L-M42-AD-Q6-1C1
				QS-8	537473	VUVB-L-M42-AD-Q8-1C1
			110 V AC	QS-6	537542	VUVB-L-M42-AD-Q6-2AC1
				QS-8	537543	VUVB-L-M42-AD-Q8-2AC1
			230 V AC	QS-6	537550	VUVB-L-M42-AD-Q6-3AC1
				QS-8	537551	VUVB-L-M42-AD-Q8-3AC1
	–	Single solenoid, external pilot air supply, pneumatic spring return	24 V DC	QS-6	537480	VUVB-L-M42-AZD-Q6-1C1
				QS-8	537481	VUVB-L-M42-AZD-Q8-1C1
			110 V AC	QS-6	537558	VUVB-L-M42-AZD-Q6-2AC1
				QS-8	537559	VUVB-L-M42-AZD-Q8-2AC1
			230 V AC	QS-6	537566	VUVB-L-M42-AZD-Q6-3AC1
				QS-8	537567	VUVB-L-M42-AZD-Q8-3AC1
	–	Double solenoid, internal pilot air supply	24 V DC	QS-6	537474	VUVB-L-B42-D-Q6-1C1
				QS-8	537475	VUVB-L-B42-D-Q8-1C1
			110 V AC	QS-6	537544	VUVB-L-B42-D-Q6-2AC1
				QS-8	537545	VUVB-L-B42-D-Q8-2AC1
			230 V AC	QS-6	537552	VUVB-L-B42-D-Q6-3AC1
				QS-8	537553	VUVB-L-B42-D-Q8-3AC1
	–	Double solenoid, external pilot air supply	24 V DC	QS-6	537482	VUVB-L-B42-ZD-Q6-1C1
				QS-8	537483	VUVB-L-B42-ZD-Q8-1C1
			110 V AC	QS-6	537560	VUVB-L-B42-ZD-Q6-2AC1
				QS-8	537561	VUVB-L-B42-ZD-Q8-2AC1
			230 V AC	QS-6	537568	VUVB-L-B42-ZD-Q6-3AC1
				QS-8	537569	VUVB-L-B42-ZD-Q8-3AC1

# Solenoid valves VUVB

Technical data – Individual valves and manifold valves

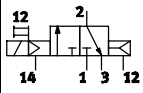
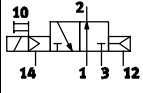
Ordering data – Semi in-line valves for sub-base or manifold rail									
Circuit symbol	Code	Description	Voltage	Pneumatic connection	Part No.	Type			
3/2-way valves									
	K	Normally closed, pilot air supply <sup>1)</sup> , pneumatic spring return	24 V DC	QS-4	537484	VUVB-S-M32C-AZD-Q4-1C1			
				QS-6	537485	VUVB-S-M32C-AZD-Q6-1C1			
				QS-8	537486	VUVB-S-M32C-AZD-Q8-1C1			
				QS-10	537487	VUVB-S-M32C-AZD-Q10-1C1			
				Without push-in connector	573993	VUVB-S-M32C-AZD-QX-1C1			
			110 V AC	QS-4	537570	VUVB-S-M32C-AZD-Q4-2AC1			
				QS-6	537571	VUVB-S-M32C-AZD-Q6-2AC1			
				QS-8	537572	VUVB-S-M32C-AZD-Q8-2AC1			
				QS-10	537573	VUVB-S-M32C-AZD-Q10-2AC1			
				Without push-in connector	573995	VUVB-S-M32C-AZD-QX-2AC1			
			230 V AC	QS-4	537586	VUVB-S-M32C-AZD-Q4-3AC1			
				QS-6	537587	VUVB-S-M32C-AZD-Q6-3AC1			
				QS-8	537588	VUVB-S-M32C-AZD-Q8-3AC1			
				QS-10	537589	VUVB-S-M32C-AZD-Q10-3AC1			
				Without push-in connector	573997	VUVB-S-M32C-AZD-QX-3AC1			
			12 V DC/ 24 V AC	Without push-in connector	573999	VUVB-S-M32C-AZD-QX-5WC1			
				N	Normally open, pneumatic spring return	24 V DC	QS-4	537488	VUVB-S-M32U-AZD-Q4-1C1
							QS-6	537489	VUVB-S-M32U-AZD-Q6-1C1
							QS-8	537490	VUVB-S-M32U-AZD-Q8-1C1
							QS-10	537491	VUVB-S-M32U-AZD-Q10-1C1
Without push-in connector	573994	VUVB-S-M32U-AZD-QX-1C1							
110 V AC	QS-4	537574				VUVB-S-M32U-AZD-Q4-2AC1			
	QS-6	537575				VUVB-S-M32U-AZD-Q6-2AC1			
	QS-8	537576				VUVB-S-M32U-AZD-Q8-2AC1			
	QS-10	537577				VUVB-S-M32U-AZD-Q10-2AC1			
	Without push-in connector	573996				VUVB-S-M32U-AZD-QX-2AC1			
230 V AC	QS-4	537590				VUVB-S-M32U-AZD-Q4-3AC1			
	QS-6	537591				VUVB-S-M32U-AZD-Q6-3AC1			
	QS-8	537592				VUVB-S-M32U-AZD-Q8-3AC1			
	QS-10	537593				VUVB-S-M32U-AZD-Q10-3AC1			
	Without push-in connector	573998				VUVB-S-M32U-AZD-QX-3AC1			
12 V DC/ 24 V AC	Without push-in connector	574000				VUVB-S-M32U-AZD-QX-5WC1			

# Solenoid valves VUVB

Technical data – Individual valves and manifold valves

Ordering data – Semi in-line valves for sub-base or manifold rail									
Circuit symbol	Code	Description	Voltage	Pneumatic connection	Part No.	Type			
4/2-way valves									
	M	Single solenoid, pneumatic spring return	24 V DC	QS-4	537492	VUVB-S-M42-AZD-Q4-1C1			
				QS-6	537493	VUVB-S-M42-AZD-Q6-1C1			
				QS-8	537494	VUVB-S-M42-AZD-Q8-1C1			
				QS-10	537495	VUVB-S-M42-AZD-Q10-1C1			
				Without push-in connector	537534	VUVB-S-M42-AZD-QX-1C1			
			110 V AC	QS-4	537578	VUVB-S-M42-AZD-Q4-2AC1			
				QS-6	537579	VUVB-S-M42-AZD-Q6-2AC1			
				QS-8	537580	VUVB-S-M42-AZD-Q8-2AC1			
				QS-10	537581	VUVB-S-M42-AZD-Q10-2AC1			
				Without push-in connector	537632	VUVB-S-M42-AZD-QX-2AC1			
			230 V AC	QS-4	537594	VUVB-S-M42-AZD-Q4-3AC1			
				QS-6	537595	VUVB-S-M42-AZD-Q6-3AC1			
				QS-8	537596	VUVB-S-M42-AZD-Q8-3AC1			
				QS-10	537597	VUVB-S-M42-AZD-Q10-3AC1			
				Without push-in connector	537636	VUVB-S-M42-AZD-QX-3AC1			
			12 V DC/ 24 V AC	Without push-in connector	545376	VUVB-S-M42-AZD-QX-5WC1			
			4/2-way valves						
				J	Double solenoid	24 V DC	QS-4	537496	VUVB-S-B42-ZD-Q4-1C1
							QS-6	537497	VUVB-S-B42-ZD-Q6-1C1
							QS-8	537498	VUVB-S-B42-ZD-Q8-1C1
QS-10	537499	VUVB-S-B42-ZD-Q10-1C1							
Without push-in connector	537535	VUVB-S-B42-ZD-QX-1C1							
110 V AC	QS-4	537582				VUVB-S-B42-ZD-Q4-2AC1			
	QS-6	537583				VUVB-S-B42-ZD-Q6-2AC1			
	QS-8	537584				VUVB-S-B42-ZD-Q8-2AC1			
	QS-10	537585				VUVB-S-B42-ZD-Q10-2AC1			
	Without push-in connector	537633				VUVB-S-B42-ZD-QX-2AC1			
230 V AC	QS-4	537598				VUVB-S-B42-ZD-Q4-3AC1			
	QS-6	537599				VUVB-S-B42-ZD-Q6-3AC1			
	QS-8	537600				VUVB-S-B42-ZD-Q8-3AC1			
	QS-10	537601				VUVB-S-B42-ZD-Q10-3AC1			
	Without push-in connector	537637				VUVB-S-B42-ZD-QX-3AC1			
12 V DC/ 24 V AC	Without push-in connector	545377				VUVB-S-B42-ZD-QX-5WC1			

# Solenoid valves VUVB

Technical data – Manifold rail



## Manifold rail G1/4 VABM

Material:  
Wrought aluminium alloy

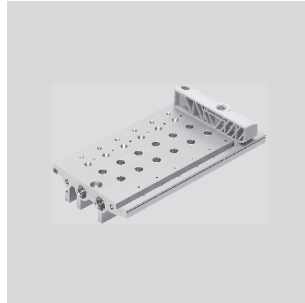

### Dimensions

Download CAD data → [www.festo.com](http://www.festo.com)

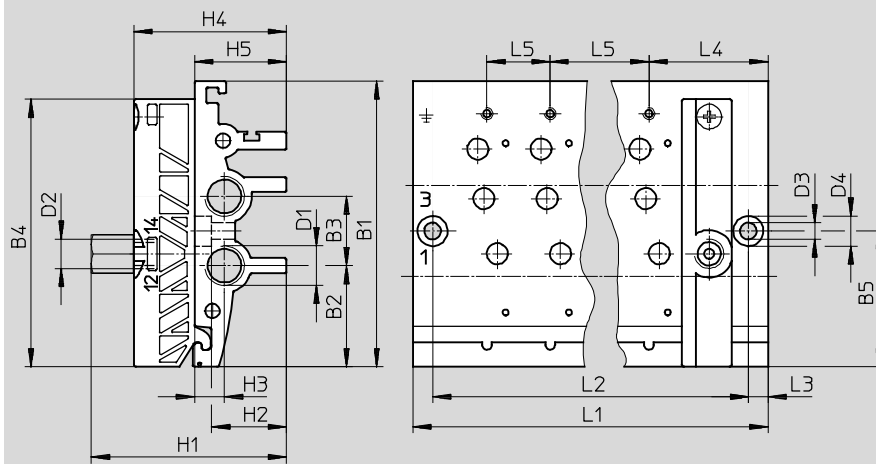

### Dimensions and ordering data

Type	L1	L2	L3	L4	L5	B1	B2	B3	B4	B5	D1	D2	D3	D4	H1	H2	H3	H4	H5
	±0.1	±0.1	±0.1	±0.1	±0.1	±0.1	±0.1	±0.1					H13	H13			±0.2		±0.2
VABM-B6-E-G14-2	85	72	6.5	39.5	21	94.7	33.5	23	88.7	45	G1/4	G1/8	5.5	10	64.7	24.8	10	50.5	30.5
VABM-B6-E-G14-3	106	93																	
VABM-B6-E-G14-4	127	114																	
VABM-B6-E-G14-5	148	135																	
VABM-B6-E-G14-6	169	156																	
VABM-B6-E-G14-7	190	177																	
VABM-B6-E-G14-8	211	198																	
VABM-B6-E-G14-9	232	219																	
VABM-B6-E-G14-10	253	240																	
VABM-B6-E-G14-11	274	219																	
VABM-B6-E-G14-12	295	282																	

# Solenoid valves VUVB

Technical data – Manifold rail



## Manifold rail G $\frac{1}{2}$ VABM

Material:  
Wrought aluminium alloy



### Dimensions

Download CAD data → [www.festo.com](http://www.festo.com)

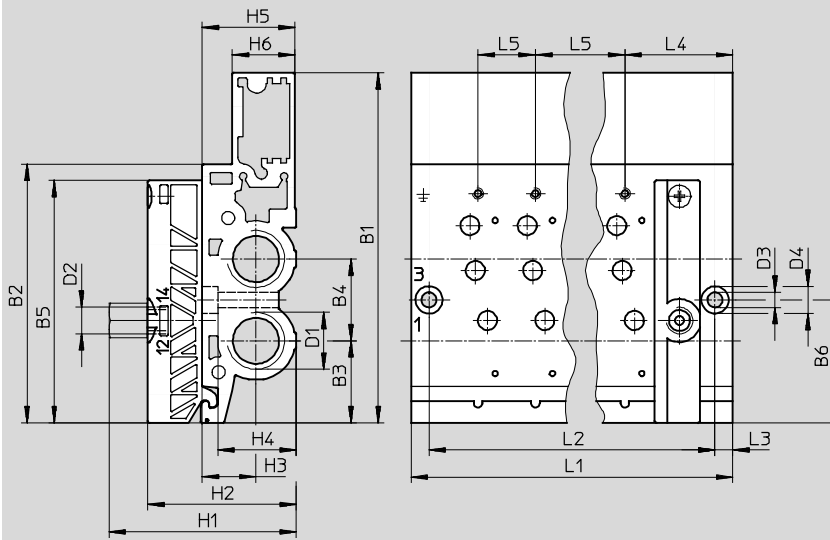

### Dimensions and ordering data

Type	L1	L2	L3	L4	L5	B1	B2	B3	B4	B5	B6	D1	D2	D3	D4	H1	H2	H3	H4	H5	H6
	±0.1	±0.1	±0.1	±0.1	±0.1	±0.1	±0.1	±0.1	±0.1					H13	H13			±0.2		±0.2	
VABM-B6-E-G12-2	85	72	6.5	39.5	21	128.25	94.7	30	30	88.7	45	G $\frac{1}{2}$	G $\frac{1}{8}$	5.5	10	68.7	54.5	19.7	28.8	34	23
VABM-B6-E-G12-3	106	93																			
VABM-B6-E-G12-4	127	114																			
VABM-B6-E-G12-5	148	135																			
VABM-B6-E-G12-6	169	156																			
VABM-B6-E-G12-7	190	177																			
VABM-B6-E-G12-8	211	198																			
VABM-B6-E-G12-9	232	219																			
VABM-B6-E-G12-10	253	240																			
VABM-B6-E-G12-11	274	219																			
VABM-B6-E-G12-12	295	282																			

# Solenoid valves VUVB

Technical data – Sub-base



## Sub-base VABS

Material:  
Reinforced polyamide

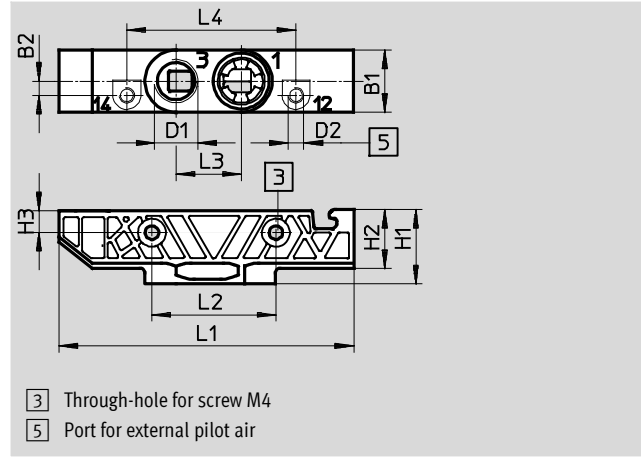

- 3 Through-hole for screw M4
- 5 Port for external pilot air

Type	D1	D2	B1	B2	H1	H2	H3	L1	L2	L3	L4
VABS-B6-PB-Q	G $\frac{1}{4}$	M5	20	4.6	23.5	18.5	7	95	40	21	54.55

Ordering data						
Valve positions	Description	Compressed air supply connection	Weight [g]	CRC	Part No.	Type
1	Internal pilot air supply	Cartridge	22	2 <sup>1)</sup>	537518	VABS-B6-PB-Q-B
1	External pilot air supply	Cartridge	22	2 <sup>1)</sup>	537519	VABS-B6-PB-Q

1) Corrosion resistance class 2 according to Festo standard 940 070  
Components subject to moderate corrosion stress. Externally visible parts with primarily decorative surface requirements which are in direct contact with a normal industrial environment or media such as coolants or lubricating agents.

# Valve terminals VTUB

Peripherals overview



## Overview – Valve terminal VTUB

Valve terminal with electrical multi-pin plug connection

- 25-pin Sub-D multi-pin plug connection  
Code: SD

Valve terminals with electrical multi-pin plug connection are available in gradations from 2 to max. 16 valve positions.

Each valve position can either be equipped with a valve or a blanking plate.

A maximum of 24 solenoid coils can be actuated via the electrical multi-pin plug connection.

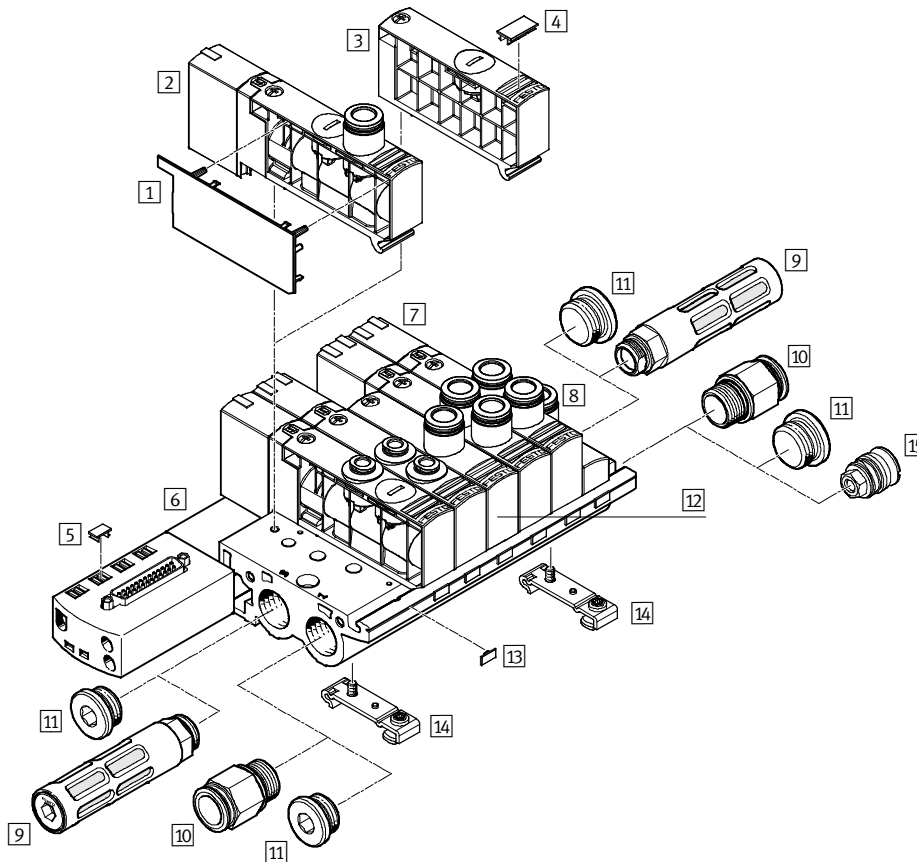

**Note**

Valve terminals are available for 4, 6, 8, 10, 12 and 16 valve positions in connection size G $\frac{1}{2}$ . On the version

with 16 valve positions, only single solenoid valves can be mounted from the ninth valve position onwards.

# Valve terminals VTUB

Peripherals overview

FESTO

Accessories		
	Brief description	→ Page/Internet
1	Cover for valve housing VAMC	46
2	Single solenoid valve VUVB-...-M	35
3	Blanking plate VABB	Blanking plate VABB: for vacant position, with blanking plug 44
4	Inscription label IBS-9x17	For identifying the valves 49
5	Inscription label IBS-6x10	49
6	Manifold rail VABM-B6-E-G...-6-M1	With multi-pin plug connection, for connecting max. 16 valves 41
7	Double solenoid valve VUVB-...-B	35
8	Pilot air supply module	For pilot air supply (included in the scope of delivery of the manifold rail VABM) -
9	Silencer U, UC	For fitting in exhaust ports 49
10	Push-in fitting QS	For connecting compressed air tubing with standard O.D. 48
11	Blanking plug B	49
12	Pressure zone supply module VABF	Pressure zone supply module VABF: with cartridge 43
13	Inscription label MH-BZ-80X	For identifying the manifold rail 49
14	H-rail mounting kit VAME	For mounting on the H-rail NRH-35-2000 49
15	Separator for pressure zones VABD	For mounting in the manifold rail 44

# Valve terminals VTUB

Key features



## Individual connection

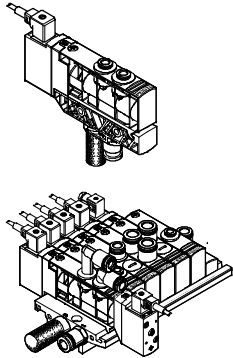

Connection is independent of the control technology used and is flexible thanks to pre-assembled cables. There are two different valve types; in-line valves and semi in-line valves for manifold rails or individual sub-bases. Between 2 ... 32 solenoid coils (divided between 2 ... 16 valve positions) can be selected with individual connection.

Valves can be used on individual sub-bases for actuators further away from the valve terminal. With an individual electrical connection, the plug is connected directly to the valve. A number of plug sockets/ plug sockets with cable can be selected for the valve terminal and for the individual sub-base:

- KMEB-1-...-LED with signal status display
- KMEB-1-230AC-... can be used up to 230 V AC
- MSSD-EB for self-assembly
- KMEB-2-24-... with signal status display
- Illuminating seal MEB-LD for signal status display

## Multi-pin plug connection

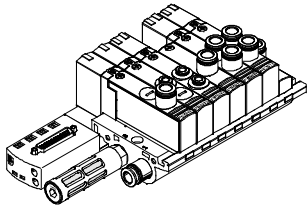

Control signals from the controller to the valve terminal are transmitted via a pre-assembled multi-core cable, which substantially reduces installation time.

This valve terminal can be equipped with 4 ... 16 valves.

Versions

- Sub-D connection

Double solenoid drive with multi-pin plug connection. The valve is equipped with an LED for signal status display.

## Wide range of pneumatic components

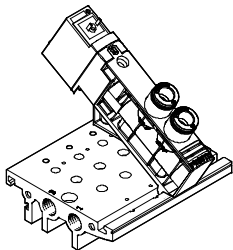

• Using the same basic valves for both the individual valves and the valve manifold permits fast and flexible conversion and multiple use of parts.

• Flexible construction thanks to assembled and tested units or single components as modules for individual configurations.

• Flow rates from 200 ... 1,000 l/min depending on the respective application through the selection of appropriate QS connections.

## Connection to the valve

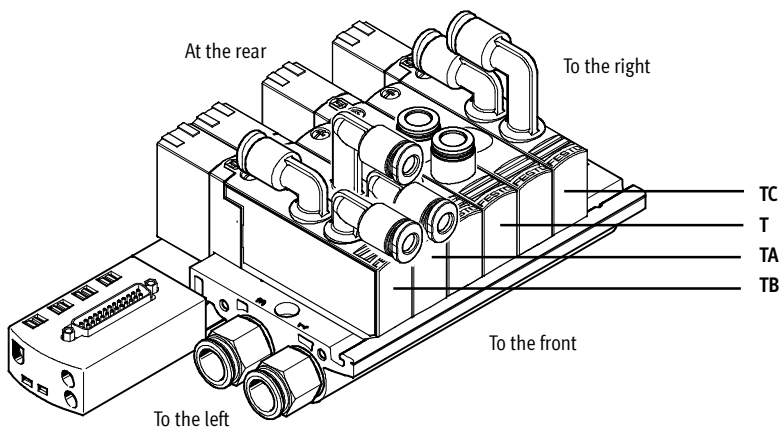

Connection positions on the valve:

- T (on top, inline)
- TA (on top, angled outlet to the front)
- TB (on top, angled outlet to the front/rear)
- TC (on top, angled outlet to the rear)

Connection sizes for connection position T:

- Push-in connector 4 mm (code P4)
- Push-in connector 6 mm (code P6)
- Push-in connector 8 mm (code P8)
- Push-in connector 10 mm (code P10)

Connection sizes for connection position TB/TA/TC:

- Push-in connector 4 mm (code P4)
- Push-in connector 6 mm (code P6)
- Push-in connector 8 mm (code P8)

# Valve terminals VTUB

Key features – Pneumatic components

## Instructions for using pressure zones

The valve terminal VTUB can be operated with 2 pressure zones, supplied either from the left or from the right. Pressure zones are created by means

of separators that can be used in the following ducts:  
 – Supply duct 1 (code TP)

or  
 – Supply duct 1 and exhaust duct 3 (code TS) or

– Exhaust duct 3 (code TR)

Duct separation		Code	Description
<p>1 Pressure zone 1 2 Pressure zone 2</p>	TP	Duct 1 closed	
<p>1 Pressure zone 1 2 Pressure zone 2</p>	TS	Duct 1/3 closed	
<p>1 Pressure zone 1 2 Pressure zone 2</p>	TR	Duct 3 closed	

## Separator VABD-B6

- - Note

The separator can also be fitted subsequently using a screwdriver/ socket spanner.

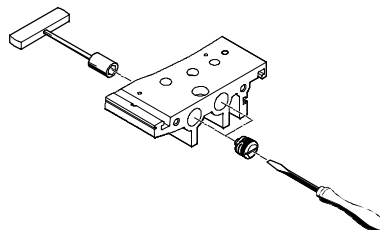
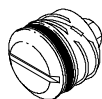

# Valve terminals VTUB

Key features – Display and operation

## Identification system

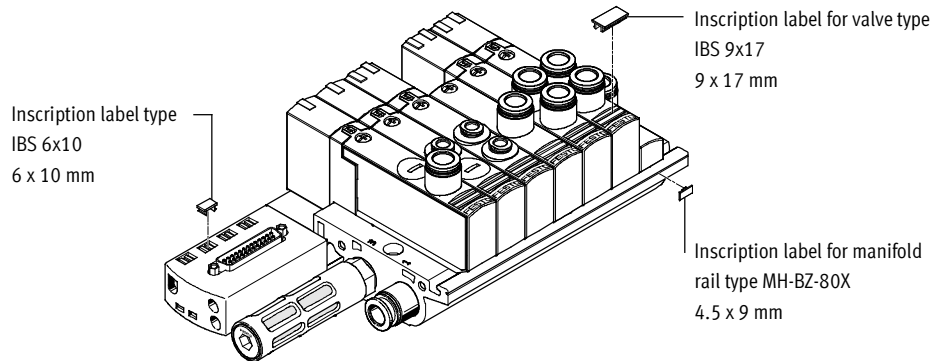

Inscription labels can be applied to the valves and manifold rails to identify them.

- Inscription labels for valve type IBS-9x17  
Part No. 161937
- Inscription labels for manifold rail type MH-BZ-80X  
Part No. 197259

## Display and operation

Each solenoid coil can be allocated an LED which indicates its signal status. Suitable plug sockets with cable can be found on page 50. On the multi-pin variant the LED is integrated in the valve.

The manual override (MO) enables the valve to be activated without electronic control or power supply.

The valve is switched by pushing the manual override. The set switching status can be secured by rotating the manual override.

**Note**  
A manually actuated valve (manual override) cannot be reset electrically. Conversely, an electrically actuated valve cannot be reset using the mechanical manual override.

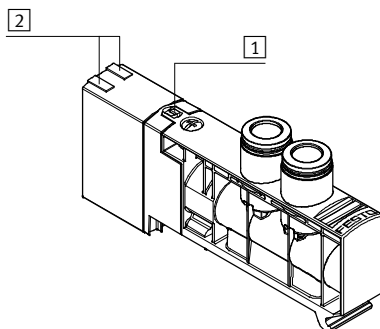

- 1 Optional manual override (non-detenting and turning with detent using a screwdriver)
- 2 LED signal status display per solenoid coil

# Valve terminals VTUB

Key features – Display and operation

## Manual override (MO)

### MO with automatic return (non-detenting)

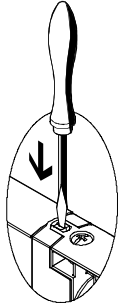

Press in the stem of the MO with a pointed object or screwdriver.  
 → Valve is in switching position  
 Remove the pointed object or screwdriver.  
 Spring force pushes the stem of the MO back.  
 → Valve returns to normal position.

### MO with detent (turning with detent)<sup>1)</sup>

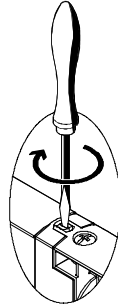

Press in the stem of the MO using a pointed object or screwdriver until the valve switches and then turn the stem clockwise by 90° until the stop is reached.  
 → Valve remains in switching position  
 Turn the stem anti-clockwise by 90° until the stop is reached and then remove the pointed object or screwdriver.  
 Spring force pushes the stem of the MO back.  
 → Valve returns to normal position.

1) Not with double solenoid valve code J for electrical multi-pin plug connection (double solenoid valve)

## Mounting – Valve terminal

Sturdy terminal mounting thanks to:

- Two through-holes for wall mounting
- Integrated attachment for H-rail mounting

### Wall mounting

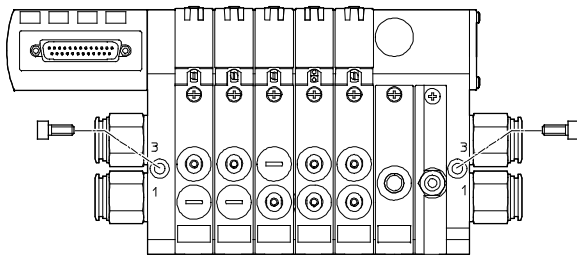

The valve terminal VTUB is screwed onto the mounting surface using two M5 screws.

### H-rail mounting

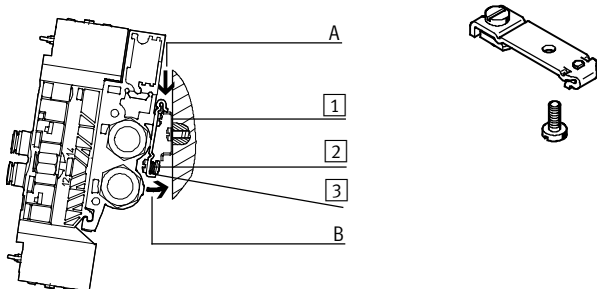

The valve terminal VTUB is hooked onto the H-rail (see arrow A). The valve terminal VTUB is then swivelled on the H-rail and secured in place with the clamping component (see arrow B).

- 1 H-rail
- 2 Self-tapping M4x8 screw of the H-rail clamping unit
- 3 Clamping component of the H-rail clamping unit

For H-rail mounting of the valve terminal you will need the mounting kit VAME-B6-T. This permits mounting of the valve terminal on an H-rail to EN 60715.

# Valve terminals VTUB

Key features – Electrical components



## Protective circuits for plug-in valves for multi-pin terminals

24 V DC version for single solenoid valve

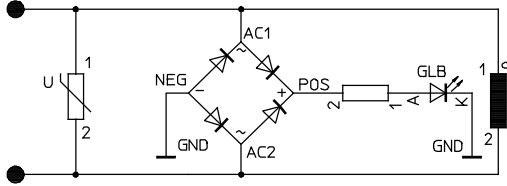

24 V DC version for double solenoid valve

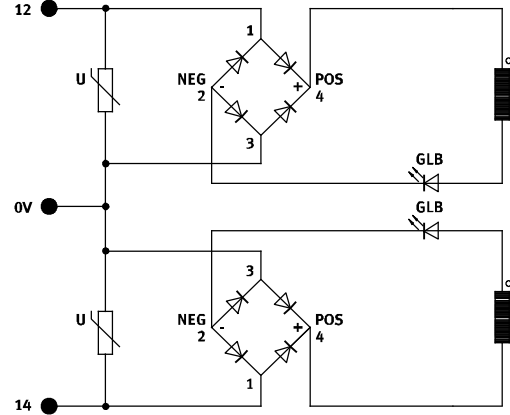

## Pin allocation – Sub-D plug

	Connecting cable, 25-wire			Connecting cable, 15-wire		
	Pin	Address/coil	Wire colour <sup>1)</sup>	Pin	Address/coil	Wire colour <sup>1)</sup>
	1	0	WH	1	0	WH
	2	1	BN	2	1	BN
	3	2	GN	3	2	GN
	4	3	YE	4	3	YE
	5	4	GY	5	4	GY
	6	5	PK	6	5	PK
	7	6	BU	7	6	BU
	8	7	RD	8	7	RD
	9	8	BK	9	8	BK
	10	9	VT	10	9	VT
	11	10	GY PK	11	10	GY PK
	12	11	RD BU	12	11	RD BU
	13	12	GN WH	13	-	-
	14	13	BN GN	14	-	-
	15	14	YE WH	15	-	-
	16	15	BN YE	16	-	-
	17	16	GY WH	17	-	-
	18	17	BN GY	18	-	-
	19	18	WH PK	19	-	-
	20	19	BN PK	20	-	-
	21	20	BU WH	21	-	-
	22	21	BN BU	22	-	-
	23	22	RD WH	23	-	WH GN
	24	23	BN RD	24	-	BN GN
	25	0 V	BK WH	25	0 V	WH YE

Note  
The drawing shows the view onto the pins of the Sub-D plug.

1) To IEC 757

# Valve terminals VTUB

Key features – Instructions for use

FESTO

## Equipment

Operate system equipment with unlubricated compressed air if possible. Festo valves and cylinders are designed so that, if used as designated, they will not require additional lubrication and will still achieve a long service life. The quality of compressed air downstream of the compressor must correspond to that of unlubricated compressed air. If possible, do not operate all of your system equipment with lubricated compressed air. The lubricators should, where possible, always be installed directly upstream of the actuator used.

Incorrect additional oil and too high an oil content in the compressed air reduce the service life of the valve terminal. Use Festo special oil OFSW-32 or the alternatives listed in the Festo catalogue (as specified in DIN 51524 HLP32; basic oil viscosity 32 CST at 40 °C).

### Bio-oils

When using bio-oils (oils which are based on synthetic or native ester, e.g. rapeseed oil methyl ester), the maximum residual oil content of 0.1 mg/m<sup>3</sup> must not be exceeded (see ISO 8573-1 Class 2).

### Mineral oils

When using mineral oils (e.g. HLP oils to DIN 51524, parts 1 to 3) or similar oils based on poly-alpha-olefins (PAO), the maximum residual oil content of 5 mg/m<sup>3</sup> must not be exceeded (see ISO 8573-1 Class 4). A higher residual oil content irrespective of the compressor oil cannot be permitted, as the basic lubricant would be flushed out over time.

# Valve terminals VTUB



Type codes – Terminal valves

		VUVB	-	S	-	M32C	-	A	Z	D	-	Q4	-	1	T1	L
<b>Valve series</b>																
VUVB	Solenoid valve															
<b>Design</b>																
S	Semi in-line valve															
<b>Valve function</b>																
M32C	3/2-way valve, normally closed															
M32U	3/2-way valve, normally open															
M42	4/2-way valve, single solenoid															
B42	4/2-way valve, double solenoid															
<b>Reset method</b>																
-	None (double solenoid)															
A	Pneumatic reset															
<b>Pilot air supply</b>																
-	Internal															
Z	External															
<b>Manual override</b>																
D	Non-detenting/detenting															
<b>Pneumatic connection</b>																
Q4	For tubing O.D. 4 mm															
Q6	For tubing O.D. 6 mm															
Q8	For tubing O.D. 8 mm															
Q10	For tubing O.D. 10 mm															
X	Without push-in connector															
<b>Operating voltage</b>																
1	24 V DC															
<b>Electrical connection</b>																
T1	Plug-in, connection for multi-pin plug															
<b>Signal status display</b>																
L	LED															

# Valve terminals VTUB

Technical data – Terminal valves

FESTO

-  Voltage  
24 V DC
-  Pressure  
-0.9 ... +8 bar
-  Temperature range  
-5 ... +50 °C

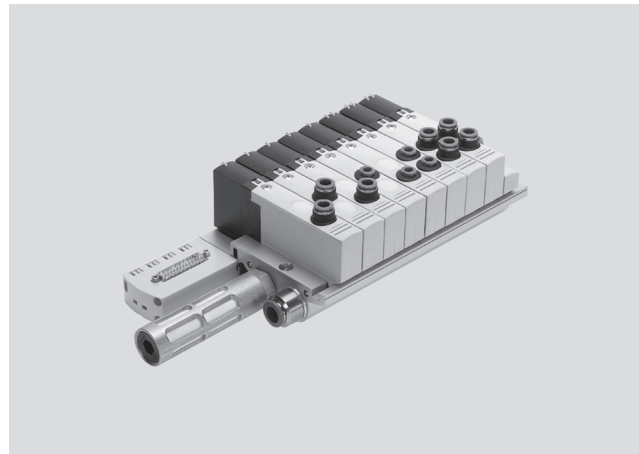

General technical data				
Valve function		3/2-way, single solenoid	4/2-way, single solenoid	4/2-way, double solenoid
Design	Piston spool valve			
Sealing principle	Soft			
Actuation type	Electric			
Reset method	Pneumatic spring			-
Type of control	Piloted			
Pilot air supply	Internal or external			
Direction of flow	Non-reversible			
Exhaust function	No flow control			
Manual override	Non-detenting, detenting			Non-detenting
Type of mounting	Via through-hole			
Mounting position	Any			
Width	[mm]	20		
Nominal size	[mm]	7		
Pneumatic connections				
Supply port	1	G $\frac{1}{2}$ (sub-base)		
Exhaust port	3	G $\frac{1}{2}$ (sub-base)		
Working lines	2/4	QS-4, QS-6, QS-8, QS-10		
External pilot air connection	12/14	M5 (sub-base)		
Standard nominal flow rate	qnN	[l/min]	200 (QS-4); 500 (QS-6); 800 (QS-8); 1,000 (QS-10)	

Operating and environmental conditions			
Operating medium	Compressed air in accordance with ISO 8573-1:2010 [7:4:4]		
Note on operating/pilot medium	Operation with lubricated medium possible (in which case lubricated operation will always be required)		
Operating pressure	[bar]	-0.9 ... +8	
Operating pressure for valve terminal with internal pilot air supply	[bar]	2 ... 8	
Pilot pressure	[bar]	2 ... 8	
Ambient temperature	[°C]	-5 ... +50	
Temperature of medium	[°C]	-5 ... +50	
Storage temperature <sup>1)</sup>	[°C]	-20 ... +40	
Note on materials	RoHS-compliant		
CE mark	To EU EMC Directive		

1) Long-term storage

-  - Note

A filter must be installed upstream of air getting into the valve (e.g. when valves operated in vacuum mode. This prevents any foreign matter in the intake operating a suction cup).

# Valve terminals VTUB

Technical data – Terminal valves



Electrical data			
Valve function	3/2-way, single solenoid	4/2-way, single solenoid	4/2-way, double solenoid
Electrical connection	Socket for multi-pin plug		
Nominal operating voltage [V DC]	24		
Permissible voltage fluctuations	±10%		
Electrical power consumption [W]	1.5	1.5	3.3 (following a current reduction 0.1)
Protection class to EN 60529	IP65		

Valve switching times [ms]			
Valve function	3/2-way, single solenoid	4/2-way, single solenoid	4/2-way, double solenoid
On	20	20	–
Off	20	20	–
Changeover	–	–	20

### Pilot pressure p2 as a function of working pressure p1

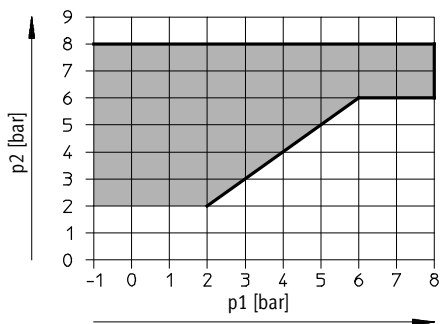

### Materials – Valves

Sectional view

Single solenoid

Double solenoid

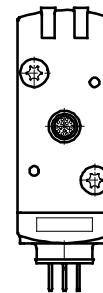
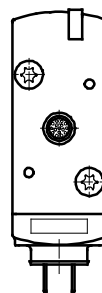
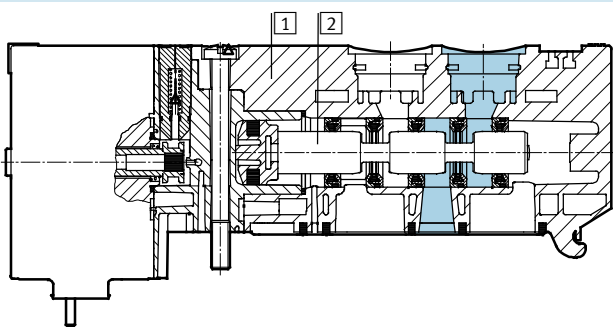

1	Housing	Reinforced polyamide
2	Piston spool	Wrought aluminium alloy
–	Seals	Nitrile rubber, hydrogenated nitrile rubber, fluoro elastomer

### Materials

Manifold rail with multi-pin plug	Wrought aluminium alloy
Pressure zone supply module	Reinforced polyamide
Blanking plate for vacant position	Reinforced polyamide

# Valve terminals VTUB

Technical data – Terminal valves

Product weight	
Approx. weight	[g]
Manifold rail with multi-pin plug	
• 4 valve positions	690
• 6 valve positions	915
• 8 valve positions	1,150
• 10 valve positions	1,380
• 12 valve positions	1,620
• 16 valve positions	2,100
Pressure zone supply module	30
Valves	
• Single solenoid (code K, N, M)	150
• Double solenoid (code J)	220
Blanking plate for vacant position	25

## Dimensions – 3/2-way and 4/2-way valve, single solenoid

Download CAD data → [www.festo.com](http://www.festo.com)

For electrical multi-pin plug

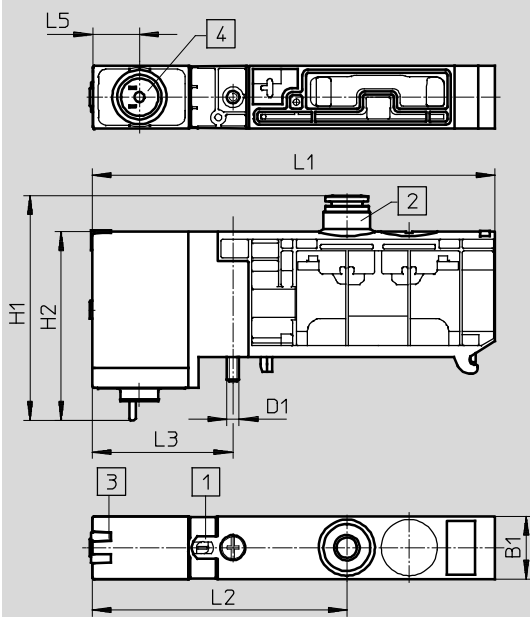

- 1 Manual override
- 2 Fitting QS
- 3 LED display
- 4 Plug for electrical interlinking

Type	B1	D1	H1	H2	L1	L2	L3	L5
VUVB-S-M32--QS4	20	M4	57	60.3	128.95	81.5	45	15
VUVB-S-M32--QS6			60					
VUVB-S-M32--QS8			63					
VUVB-S-M32--QS10			65					

# Valve terminals VTUB

Technical data – Terminal valves



## Dimensions – 4/2-way valve, double solenoid

Download CAD data → [www.festo.com](http://www.festo.com)

For electrical multi-pin plug

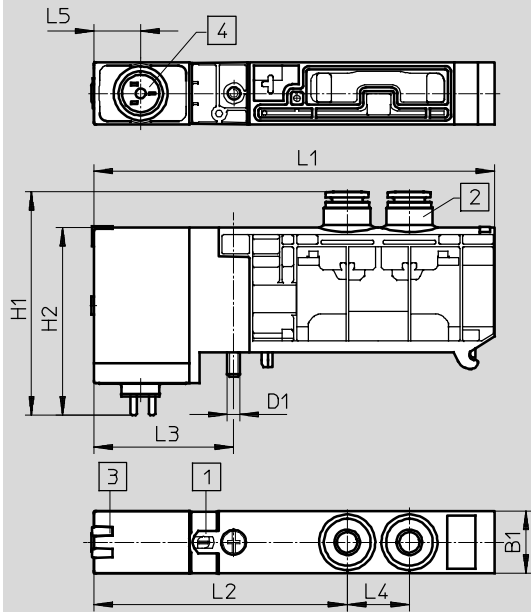

- 1 Manual override
- 2 Fitting QS
- 3 LED display
- 4 Plug for electrical interlinking

Type	B1	D1	H1	H2	L1	L2	L3	L4	L5
VUVB-S-B42--QS4	20	M4	57	60.3	128.95	81.5	45	20	15
VUVB-S-B42--QS6			60						
VUVB-S-B42--QS8			63						
VUVB-S-B42--QS10			65						

# Valve terminals VTUB

Technical data – Terminal valves



## Dimensions – Valve terminal

Download CAD data → [www.festo.com](http://www.festo.com)

With electrical multi-pin plug

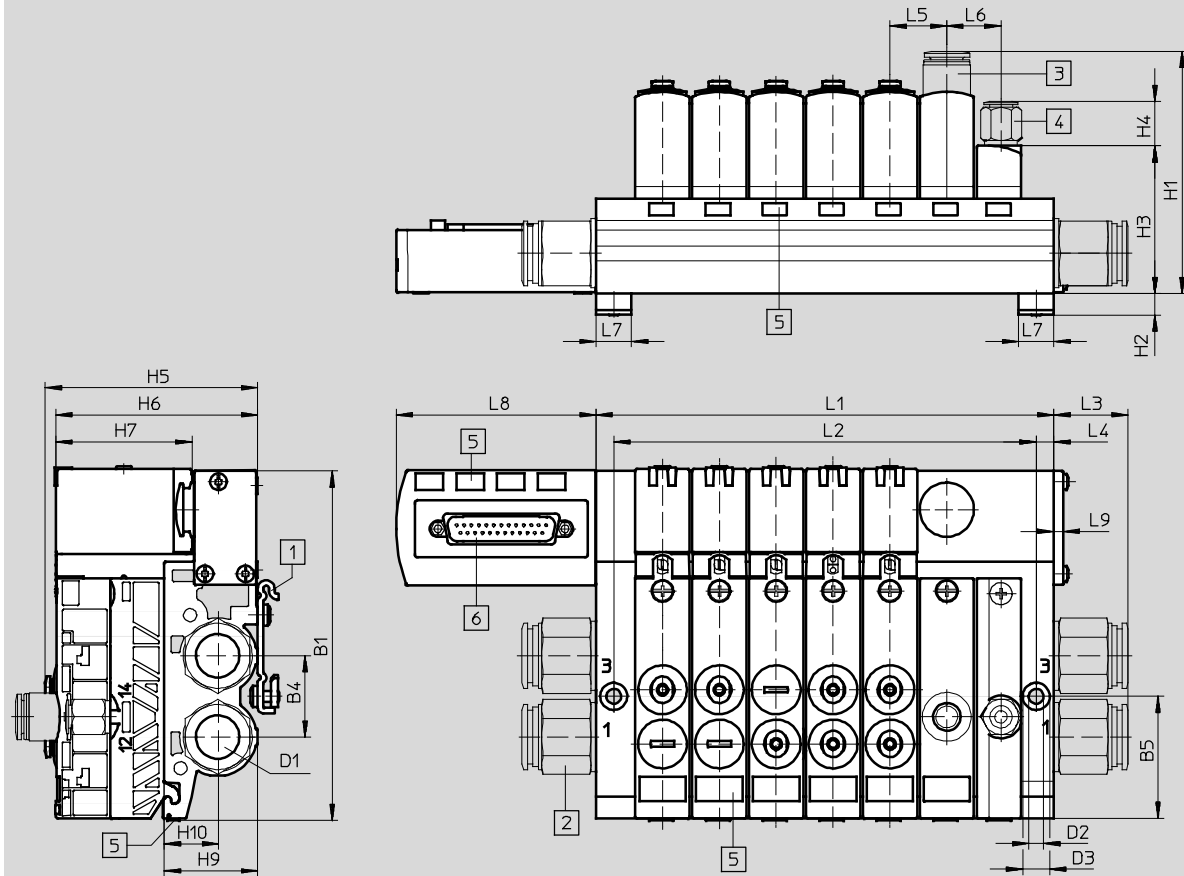

- 1 Attachment VAME-B6-T (optional) for mounting rail
- 2 Push-in fittings (optional)
- 3 Push-in fittings (optional, only with pressure zone supply module; blanking plate only with blanking plug)
- 4 Push-in fitting (optional, only with S types)
- 5 Inscription label (optional)
- 6 Sub-D plug

Type	B1	B4	B5	D1	D2 ∅ H13	D3 ∅ H13	H1	H2	H3	H4	H6	H7	H9	H10	L1 ± 0.2	L2 ± 0.1	L3	L4	L5	L6	L7	L8	L9
VTUB-4	129.1	30	4	G½	5.5	10	89.4	8	54.5	16.4	74.5	50.1	34.5	19.7	127	114	27.4	6.5	21	20	13	73.8	3.5
VTUB-6															169	156							
VTUB-8															211	198							
VTUB-10															253	240							
VTUB-12															295	282							
VTUB-16															379	366							

Type	H5
QSPK18-4	78.5
QSPK18-6	78.5
QSPK18-8	86
QSPK18-10	89.4

# Valve terminals VTUB

Technical data – Terminal valves



Ordering data – Valves for valve terminal						
Circuit symbol	Code	Description	Voltage	Pneumatic connection	Part No.	Type
<b>3/2-way valves</b>						
	K	Normally closed, pneumatic spring return	24 V DC	QS-4	537602	VUVB-S-M32C-AZD-Q4-1T1L
				QS-6	537603	VUVB-S-M32C-AZD-Q6-1T1L
				QS-8	537604	VUVB-S-M32C-AZD-Q8-1T1L
				QS-10	537605	VUVB-S-M32C-AZD-Q10-1T1L
				Without push-in connector	574001	VUVB-S-M32C-AZD-QX-1T1L
	N	Normally open, pneumatic spring return	24 V DC	QS-4	537606	VUVB-S-M32U-AZD-Q4-1T1L
				QS-6	537607	VUVB-S-M32U-AZD-Q6-1T1L
				QS-8	537608	VUVB-S-M32U-AZD-Q8-1T1L
				QS-10	537609	VUVB-S-M32U-AZD-Q10-1T1L
				Without push-in connector	574002	VUVB-S-M32U-AZD-QX-1T1L
<b>4/2-way valves</b>						
	M	Single solenoid, pneumatic spring return	24 V DC	QS-4	537610	VUVB-S-M42-AZD-Q4-1T1L
				QS-6	537611	VUVB-S-M42-AZD-Q6-1T1L
				QS-8	537612	VUVB-S-M42-AZD-Q8-1T1L
				QS-10	537613	VUVB-S-M42-AZD-Q10-1T1L
				Without push-in connector	537640	VUVB-S-M42-AZD-QX-1T1L
	J	Double solenoid	24 V DC	QS-4	537614	VUVB-S-B42-ZD-Q4-1T1L
				QS-6	537615	VUVB-S-B42-ZD-Q6-1T1L
				QS-8	537616	VUVB-S-B42-ZD-Q8-1T1L
				QS-10	537617	VUVB-S-B42-ZD-Q10-1T1L
				Without push-in connector	537641	VUVB-S-B42-ZD-QX-1T1L

# Valve terminals VTUB

Technical data – Manifold rail



**Manifold rail with electrical multi-pin plug**  
**VABM-...-M1**

Material:  
 Wrought aluminium alloy



## Dimensions

Download CAD data → [www.festo.com](http://www.festo.com)

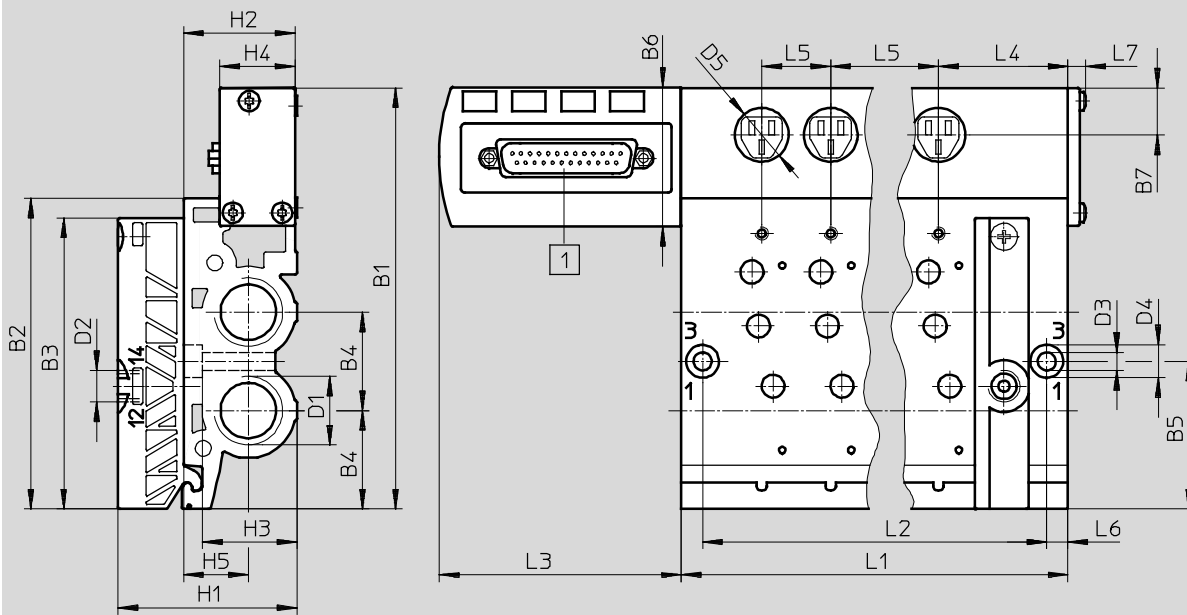

1 Sub-D plug

Type	B1 ±0.25	B2 ±0.2	B3	B4 ±0.2	B5	B6	B7	D1	D2	D3 ∅ H13	D4 ∅ H13	D5 ∅	H1	H2 ±0.2	H3	H4	H5 ±0.2
VABM-B6-E-G12-4-M1	128.3	94.7	88.7	30	45	42.2	14.3	G1/2	G1/8	5.5	10	16.4	54.5	34	28.8	23	19.7
VABM-B6-E-G12-6-M1																	
VABM-B6-E-G12-8-M1																	
VABM-B6-E-G12-10-M1																	
VABM-B6-E-G12-12-M1																	
VABM-B6-E-G12-16-M1																	

Type	L1	L2	L3	L4 ±0.1	L5 ±0.1	L6 ±0.1	L7
VABM-B6-E-G12-4-M1	127	114	73.8	39.5	21	6.5	5.4
VABM-B6-E-G12-6-M1	169	156					
VABM-B6-E-G12-8-M1	211	198					
VABM-B6-E-G12-10-M1	253	240					
VABM-B6-E-G12-12-M1	295	282					
VABM-B6-E-G12-16-M1	379	366					

# Valve terminals VTUB

Technical data – Manifold rail



Dimensions and ordering data			
Weight [g]	CRC	Part No.	Type
690	2 <sup>1)</sup>	537618	VABM-B6-E-G12-4-M1
915	2 <sup>1)</sup>	537619	VABM-B6-E-G12-6-M1
1,150	2 <sup>1)</sup>	537620	VABM-B6-E-G12-8-M1
1,380	2 <sup>1)</sup>	537621	VABM-B6-E-G12-10-M1
1,620	2 <sup>1)</sup>	537622	VABM-B6-E-G12-12-M1
2,100	2 <sup>1)</sup>	550186	VABM-B6-E-G12-16-M1

- 1) Corrosion resistance class 2 according to Festo standard 940 070  
Components subject to moderate corrosion stress. Externally visible parts with primarily decorative surface requirements which are in direct contact with a normal industrial environment or media such as coolants or lubricating agents.

# Solenoid valves VUVB/valve terminals VTUB

Accessories

## Cover for valve housing VAMC

Material:  
Polyamide

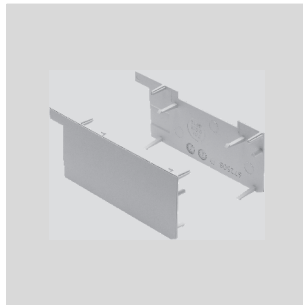

Ordering data		
CRC	Part No.	Type
2 <sup>1)</sup>	537512	VAMC-B6-C

1) Corrosion resistance class 2 according to Festo standard 940 070  
Components subject to moderate corrosion stress. Externally visible parts with primarily decorative surface requirements which are in direct contact with a normal industrial environment or media such as coolants or lubricating agents.

## Pressure zone supply module VABF

Material:  
Reinforced polyamide

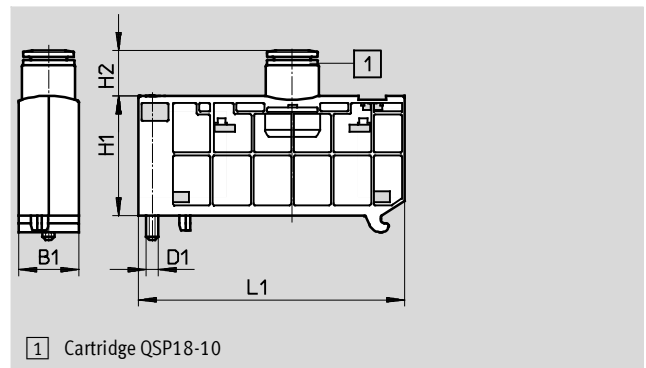

Type	D1	B1	H1	H2	L1
VABF-B6-...	M4	20	40	15	88.5

Ordering data		
	CRC	Part No. Type
For individual electrical connection	2 <sup>1)</sup>	537517 VABF-B6-P1A5-Q10
For multi-pin plug connection	2 <sup>1)</sup>	537624 VABF-B6-P1A9-Q10

1) Corrosion resistance class 2 according to Festo standard 940 070  
Components subject to moderate corrosion stress. Externally visible parts with primarily decorative surface requirements which are in direct contact with a normal industrial environment or media such as coolants or lubricating agents.

# Solenoid valves VUVB/valve terminals VTUB

Accessories

## Blanking plate VABB

Material:  
Reinforced polyamide

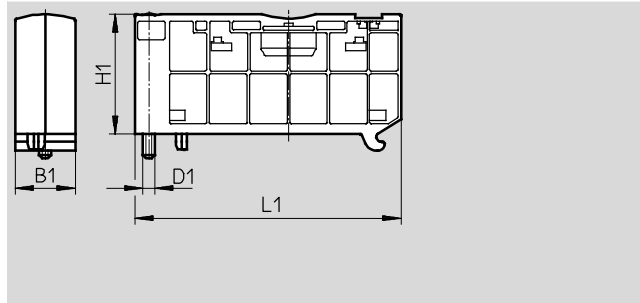

Type	B1	D1	H1	L1
VABB-B-6-E	20	M4	40	88.5

Ordering data				
		CRC	Part No.	Type
For individual electrical connection	–	2 <sup>1)</sup>	537513	VABB-B6-E
For multi-pin plug connection	With cover cap for multi-pin plug connection	2 <sup>1)</sup>	537623	VABB-B6-ET

1) Corrosion resistance class 2 according to Festo standard 940 070  
Components subject to moderate corrosion stress. Externally visible parts with primarily decorative surface requirements which are in direct contact with a normal industrial environment or media such as coolants or lubricating agents.

## Separator for pressure zones VABD

Material:  
Steel

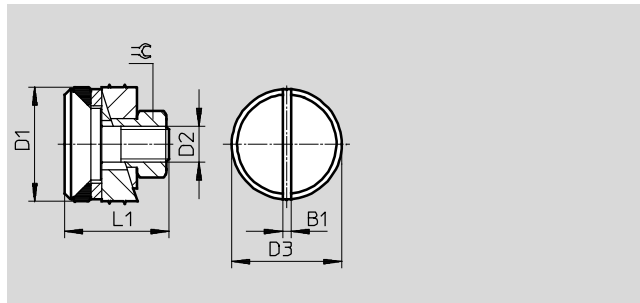

Type	B1	D1	D2	D3	L1	⌀
VABD-B6-14-P-C	1.6	11.7	M4	11.3	13.9	7
VABD-B6-12-P-C	1.4	19	M6	18.3	17.3	10

Dimensions and ordering data				
Manifold rail		CRC	Part No.	Type
G <sup>1</sup> / <sub>4</sub>		2 <sup>1)</sup>	537515	VABD-B6-14-P-C
G <sup>1</sup> / <sub>2</sub>		2 <sup>1)</sup>	537516	VABD-B6-12-P-C

1) Corrosion resistance class 2 according to Festo standard 940 070  
Components subject to moderate corrosion stress. Externally visible parts with primarily decorative surface requirements which are in direct contact with a normal industrial environment or media such as coolants or lubricating agents.

# Solenoid valves VUVB/valve terminals VTUB

Accessories

## H-rail mounting kit VAME

Material:  
Steel

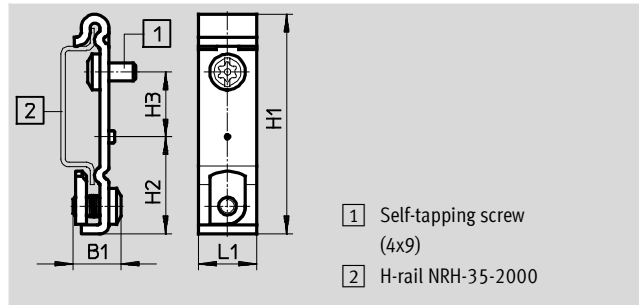

Type	B1	H1	H2	H3	L1
VAME-B6-T	10.7	49.1	21.7	14.5	13

Ordering data	
CRC	Part No. Type
2 <sup>1)</sup>	537514 VAME-B6-T

1) Corrosion resistance class 2 according to Festo standard 940 070  
Components subject to moderate corrosion stress. Externally visible parts with primarily decorative surface requirements which are in direct contact with a normal industrial environment or media such as coolants or lubricating agents.

# Solenoid valves VUVB/valve terminals VTUB

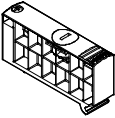
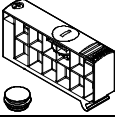
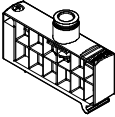
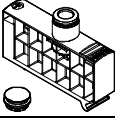
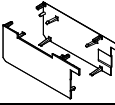

Accessories

**FESTO**

Ordering data					
	Code	Valve function	Pneumatic connection	Part No.	Type
<b>Blanking plate for vacant position</b>					
	L	For individual electrical connection	–	537513	VABB-B6-E
	L	For multi-pin plug connection with cover cap for electrical multi-pin plug connection	–	537623	VABB-B6-ET
<b>Pressure zone supply module</b>					
	S	Additional supply for individual electrical connection	QS-10	537517	VABF-B6-P1A5-Q10
	S	Additional supply for multi-pin plug connection with cover cap for electrical multi-pin plug connection	QS-10	537624	VABF-B6-P1A9-Q10
<b>Cover plate for valve housing</b>					
	C	Valve design with cover	–	537512	VAMC-B6-C

# Solenoid valves VUVB/valve terminals VTUB

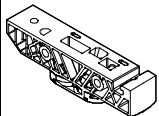
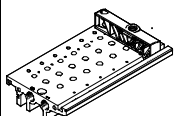
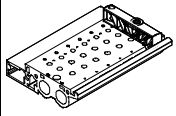
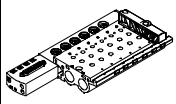

Accessories

Ordering data						
	Code	Description	Valve positions	Compressed air supply connection	Part No.	Type
<b>Sub-base for individual valve</b>						
	-	Internal pilot air supply	1	Cartridge	537518	VABS-B6-PB-Q-B
	-	External pilot air supply	1	Cartridge	537519	VABS-B6-PB-Q
<b>Manifold rail for individual electrical connection</b>						
	-		2	G1/4	537500	VABM-B6-E-G14-2
			3		545815	VABM-B6-E-G14-3
			4		537501	VABM-B6-E-G14-4
			5		545816	VABM-B6-E-G14-5
			6		537502	VABM-B6-E-G14-6
			7		545817	VABM-B6-E-G14-7
			8		537503	VABM-B6-E-G14-8
			9		545818	VABM-B6-E-G14-9
			10		537504	VABM-B6-E-G14-10
			11		545819	VABM-B6-E-G14-11
			12		537505	VABM-B6-E-G14-12
		-			2	G1/2
			3	545820	VABM-B6-E-G12-3	
			4	537507	VABM-B6-E-G12-4	
			5	545821	VABM-B6-E-G12-5	
			6	537508	VABM-B6-E-G12-6	
			7	545822	VABM-B6-E-G12-7	
			8	537509	VABM-B6-E-G12-8	
			9	545823	VABM-B6-E-G12-9	
			10	537510	VABM-B6-E-G12-10	
			11	545824	VABM-B6-E-G12-11	
			12	537511	VABM-B6-E-G12-12	
			16	564835	VABM-B6-E-G12-16	
<b>Manifold rail for valve terminal with multi-pin plug connection</b>						
	-		4	G1/2	537618	VABM-B6-E-G12-4-M1
			6		537619	VABM-B6-E-G12-6-M1
			8		537620	VABM-B6-E-G12-8-M1
			10		537621	VABM-B6-E-G12-10-M1
			12		537622	VABM-B6-E-G12-12-M1
			16		550186	VABM-B6-E-G12-16-M1
<b>Separator</b>						
	TP, TS,	For duct separation	-	G1/4	537515	VABD-B6-14-P-C
	TR		-	G1/2	537516	VABD-B6-12-P-C

# Solenoid valves VUVB/valve terminals VTUB

Accessories

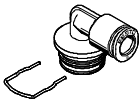
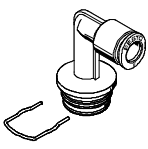

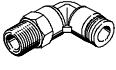
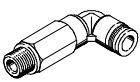



**FESTO**

Ordering data						
	Code	Description	Tubing O.D.	Packaging unit	Part No.	Type
<b>Cartridge with push-in connector</b>						
	–	In-line connection Ø 18 mm	4 mm	10 pieces	<b>130839</b>	<b>QSPK18-4</b>
	–		6 mm	10 pieces	<b>130840</b>	<b>QSPK18-6</b>
	–		8 mm	10 pieces	<b>130841</b>	<b>QSPK18-8</b>
	–		10 mm	10 pieces	<b>130842</b>	<b>QSPK18-10</b>
	–	L-shaped connection Ø 18 mm	4 mm	10 pieces	<b>130843</b>	<b>QSPLK18-4</b>
	–		6 mm	10 pieces	<b>130844</b>	<b>QSPLK18-6</b>
	–		8 mm	10 pieces	<b>130845</b>	<b>QSPLK18-8</b>
	–		10 mm	10 pieces	<b>132639</b>	<b>QSPLK18-10</b>
	–		3/8"	10 pieces	<b>132641</b>	<b>QSPLK18-3/8-U</b>
	–					
	–	Extra-long L-shaped connection Ø 18 mm	4 mm	10 pieces	<b>130846</b>	<b>QSPLLK18-4</b>
	–		6 mm	10 pieces	<b>130847</b>	<b>QSPLLK18-6</b>
	–		8 mm	10 pieces	<b>130848</b>	<b>QSPLLK18-8</b>
	–		10 mm	10 pieces	<b>132640</b>	<b>QSPLLK18-10</b>
	–		3/8"	10 pieces	<b>132642</b>	<b>QSPLLK18-3/8-U</b>
	–					
<b>Push-in fitting</b> <span style="float: right;">Technical data → Internet: quick star</span>						
	–	With sealing ring connection G 1/8	6 mm	10 pieces	<b>186096</b>	<b>QS-G 1/8-6</b>
	–		8 mm	10 pieces	<b>186098</b>	<b>QS-G 1/8-8</b>
	–	With sealing ring connection G 1/4	6 mm	10 pieces	<b>186097</b>	<b>QS-G 1/4-6</b>
	–		8 mm	10 pieces	<b>186099</b>	<b>QS-G 1/4-8</b>
	–		10 mm	10 pieces	<b>186101</b>	<b>QS-G 1/4-10</b>
	–	With sealing ring connection G 1/2	12 mm	10 pieces	<b>186350</b>	<b>QS-G 1/4-12</b>
	–		16 mm	1 piece	<b>186104</b>	<b>QS-G 1/2-12</b>
	–	Connection R 1/4	12 mm	1 piece	<b>186105</b>	<b>QS-G 1/2-16</b>
	–		6 mm	10 pieces	<b>153003</b>	<b>QS-1/4-6</b>
	–		8 mm	10 pieces	<b>153005</b>	<b>QS-1/4-8</b>
	–		10 mm	10 pieces	<b>153007</b>	<b>QS-1/4-10</b>
	–	Connection R 1/2	12 mm	10 pieces	<b>164980</b>	<b>QS-1/4-12</b>
	–		10 mm	1 piece	<b>190646</b>	<b>QS-1/2-10</b>
	–		12 mm	1 piece	<b>153010</b>	<b>QS-1/2-12</b>
–	16 mm		1 piece	<b>153011</b>	<b>QS-1/2-16</b>	
<b>Push-in L-fitting</b> <span style="float: right;">Technical data → Internet: quick star</span>						
	–	With sealing ring connection G 1/8	6 mm	10 pieces	<b>186117</b>	<b>QSL-G 1/8-6</b>
	–		8 mm	10 pieces	<b>186119</b>	<b>QSL-G 1/8-8</b>
	–	With sealing ring connection G 1/4	6 mm	10 pieces	<b>186118</b>	<b>QSL-G 1/4-6</b>
	–		8 mm	10 pieces	<b>186120</b>	<b>QSL-G 1/4-8</b>
	–		10 mm	10 pieces	<b>186122</b>	<b>QSL-G 1/4-10</b>
	–	With sealing ring connection G 1/2	12 mm	10 pieces	<b>186351</b>	<b>QSL-G 1/4-12</b>
	–		16 mm	1 piece	<b>186125</b>	<b>QSL-G 1/2-12</b>
	–				<b>186126</b>	<b>QSL-G 1/2-16</b>
<b>Push-in L-fitting, long</b> <span style="float: right;">Technical data → Internet: quick star</span>						
	–	With sealing ring connection G 1/4	6 mm	10 pieces	<b>186129</b>	<b>QSL-G 1/4-6</b>
	–		8 mm	10 pieces	<b>186131</b>	<b>QSL-G 1/4-8</b>
	–		10 mm	10 pieces	<b>186133</b>	<b>QSL-G 1/4-10</b>
	–	With sealing ring connection G 1/2	12 mm	1 piece	<b>186136</b>	<b>QSL-G 1/2-12</b>
	–		16 mm	1 piece	<b>190665</b>	<b>QSL-G 1/2-16</b>

# Solenoid valves VUVB/valve terminals VTUB

FESTO



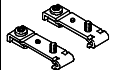

Accessories

Ordering data					
	Code	Description	Packaging unit	Part No.	Type
<b>Blanking plug</b>					
	-	Connection Ø 18 mm	10 pieces	537533	QSPC18
	-	For thread G1/4	10 pieces	3569	B-1/4
	-	For thread G1/2	10 pieces	3571	B-1/2
<b>Adapter</b>					
	-	For thread G3/8	10 pieces	545921	NPFA-A-P18-G18-F
	-	For thread G1/4	10 pieces	545922	NPFA-A-P18-G14-F
<b>Silencer</b> <span style="float: right;">Technical data → Internet: u</span>					
	-	For thread G1/4	1 piece	165004	UC-1/4
	-	For thread G1/4	1 piece	2316	U-1/4
	-	For thread G1/4	1 piece	6842	U-1/4-B
	-	For thread G1/2	1 piece	6844	U-1/2-B
<b>Inscription label</b>					
	-	Scope of delivery 24 labels in frame		161937	IBS-9x17
	-	Scope of delivery 80 labels in frame		197259	MH-BZ-80X
	-	Scope of delivery 64 labels in frame		18576	IBS-6x10
<b>H-rail mounting kit</b>					
	H	Attachment of the manifold rails to H-rails to EN 60715-TH35	1 piece	537514	VAME-B6-T

# Solenoid valves VUVB/valve terminals VTUB

Accessories

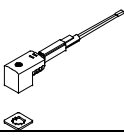
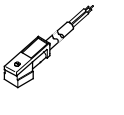
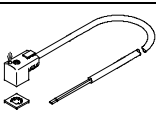
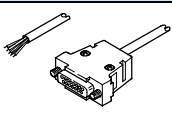
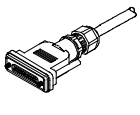
**FESTO**

Ordering data						
	Code	Description	Voltage [V]	Cable length [m]	Part No.	Type
<b>Plug socket</b> <span style="float: right;">Technical data → Internet: mssd-eb</span>						
	–	With screw terminals, for self-assembly	Up to 250 AC	–	151687	MSSD-EB
	C		Up to 250 AC	–	539712	MSSD-EB-M12
	–	With insulation displacement connection, for self-assembly	Up to 250 AC	–	192745	MSSD-EB-S-M14
<b>Plug socket with cable for individual electrical connection</b> <span style="float: right;">Technical data → Internet: kmeb</span>						
	–	Switching status display via LED, polyvinyl chloride	24 DC	2.5	151688	KMEB-1-24-2,5-LED
			24 DC	5	151689	KMEB-1-24-5-LED
		Polyvinyl chloride	Up to 240 AC	2.5	151690	KMEB-1-230AC-2,5
			Up to 240 AC	5	151691	KMEB-1-230AC-5
	C1	Switching status display via LED, polyurethane	24 DC	2.5	174844	KMEB-2-24-2,5-LED
	C2	Switching status display via LED, polyurethane	24 DC	5	174845	KMEB-2-24-5-LED
	C1	Polyurethane	Up to 230 AC	2.5	174846	KMEB-2-230AC-2,5
	C2	Polyurethane	Up to 230 AC	5	174847	KMEB-2-230AC-5
	–	Switching status display via LED, polyvinyl chloride	24 DC	2.5	547268	KMEB-3-24-2,5-LED
			24 DC	5	547269	KMEB-3-24-5-LED
		Polyvinyl chloride	24 DC	2.5	547270	KMEB-3-24-2,5
			24 DC	5	547271	KMEB-3-24-5
<b>Connecting cable for multi-pin plug to IP40</b>						
	–	Sub-D, 25-pin, up to 20 coils, polyvinyl chloride	24 DC	2.5	530046	KMP6-25P-20-2,5
			24 DC	5	530047	KMP6-25P-20-5
			24 DC	10	530048	KMP6-25P-20-10
	–	Sub-D, 25-pin, up to 12 coils, polyvinyl chloride	24 DC	2.5	530049	KMP6-25P-12-2,5
			24 DC	5	530050	KMP6-25P-12-5
			24 DC	10	530051	KMP6-25P-12-10
<b>Connecting cable for multi-pin plug to IP65</b>						
	M1	Sub-D, 25-pin, up to 12 coils, polyvinyl chloride	24 DC	2.5	538222	NEBV-S1G25-K-2.5-N-LE15
	M2		24 DC	5	538223	NEBV-S1G25-K-5-N-LE15
	M3		24 DC	10	538224	NEBV-S1G25-K-10-N-LE15
	M1	Sub-D, 25-pin, up to 24 coils, polyvinyl chloride	24 DC	2.5	538225	NEBV-S1G25-K-2.5-N-LE25
	M2		24 DC	5	538226	NEBV-S1G25-K-5-N-LE25
	M3		24 DC	10	538227	NEBV-S1G25-K-10-N-LE25
<b>Illuminating seal</b>						
	–	For indicating the signal status	12 ... 24 DC	–	151717	MEB-LD-12-24DC
	–		Up to 230 AC	–	151718	MEB-LD-230AC