

E30122

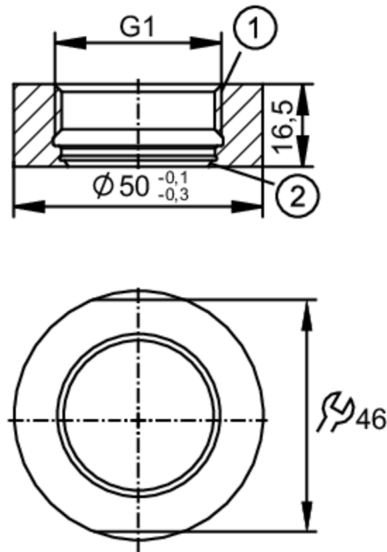

Welding adapter for process sensors

WELDING ADAPT D50/G1



- 1 G1 internal thread Aseptoflex Vario
2 sealing area

ACS EC 1935/2004 EHEDG Tested  Reg31

| Application | |
|------------------------------|---------------------------------------------------------------------------------------------------------------|
| Installation | for thin wall thicknesses |
| Pressure rating | 50 bar 5 MPa |
| Note on pressure rating | for the connection sensor - adapter |
| Tests / approvals | |
| Pressure Equipment Directive | A possible classification to PED depends on the application and has to be carried out by the user / operator. |
| Safety instructions | The compatibility between medium and product material has to be checked in all applications. |
| Mechanical data | |
| Weight [g] | 191.5 |
| Materials (wetted parts) | stainless steel (316L/1.4435) ; surface characteristics : Ra<0,4 / Rz 4 |
| Sensor connection | G 1 internal thread Aseptoflex Vario |
| Process connection | welding adapter \varnothing 50 mm |
| Sealing | Gasket |
| Accessories | |
| Items supplied | O-rings: 1 x 24 x 2, EPDM, FDA compliant, E30054 |
| Accessories (optional) | O-ring: 1 x 24 x 2, FKM, FDA compliant, E30123 |
| Remarks | |
| Pack quantity | 1 pcs. |