



- 1-channel
- 24 V DC nominal supply voltage
- 2 switch outputs
- High/low alarm selectable
- Mode of operation adjustable
- Adjustment option of 0 V ... 10 V, 0 mA ... 20 mA, of Pt100, Ni100 or thermocouple (B, E, J, K, L, N, R, S or T)
- Internal or external cold junction compensation
- Sensor burnout monitoring for thermocouples
- Sensor burnout and short-circuit monitoring for Pt100, current and voltage
- Online adjustments via serial interface to PC
- EMC acc. to NAMUR NE 21

**KFD2-GU-1**

Standard model, replaces model KFD2-GS-1.EU

**Connection**

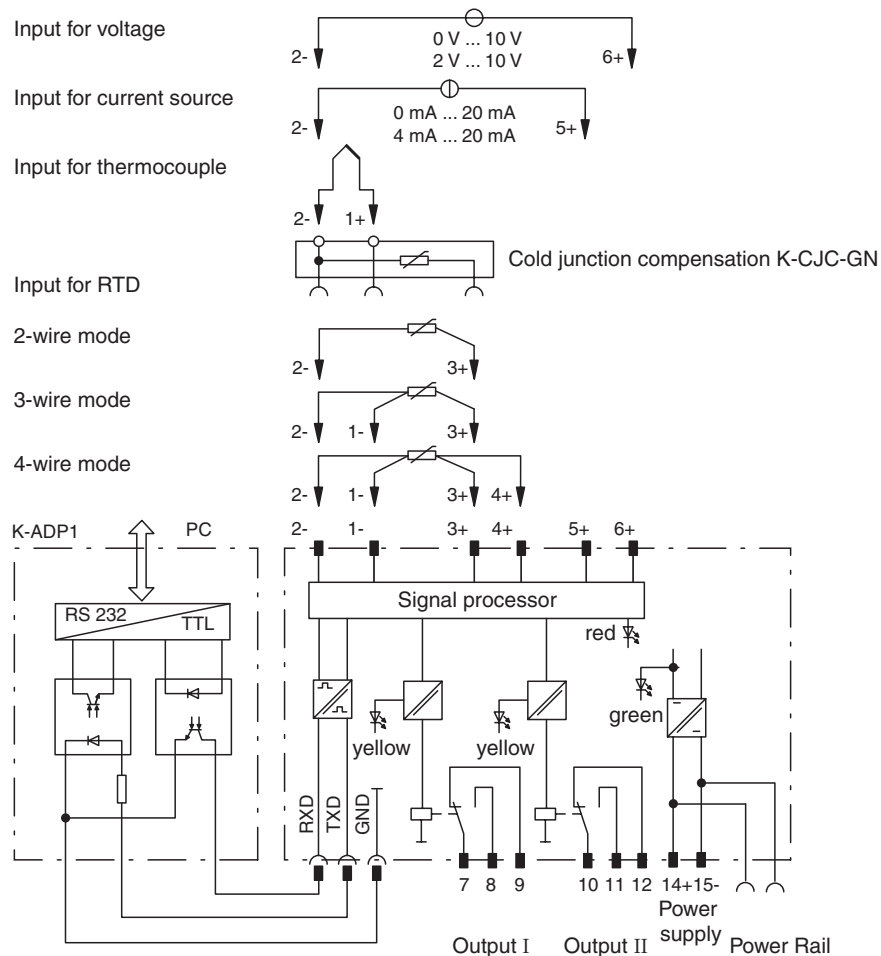

**Composition**

**Front View**

Housing type C (see system description)

LED yellow: Relay output I

LED yellow: Relay output II

Removable terminals green

LED green: Power  
LED red: Fault signal

Programming jack

Removable terminals green



<b>General specifications</b>	
Signal type	Analog input
<b>Supply</b>	
Connection	Power Rail or terminals 14+, 15-
Rated voltage	20 ... 35 V DC
Ripple	within the supply tolerance
Power loss	0.8 W
Power consumption	0.8 W
<b>Input</b>	
Connection	terminals 1, 2, 3, 4, 5, 6 ; suitable for Pt100, Ni100, thermocouples type B, E, J, K, L, N, R, S or T 0 ... 10 V, 0 ... 20 mA configuration via programming jack
Line resistance	≤ 50 Ω per lead
Measuring current	approx. 400 mA with resistance measuring sensor current for lead breakage monitoring switched off during the measurement
Load	20 Ω for 20 mA; 200 kΩ for 10 V
<b>Output</b>	
Output I	trip value: terminals 7, 8, 9
Output II	trip value: terminals 10, 11, 12
Contact loading	253 V AC / 2 A / cos φ ≥ 0.6
Mechanical life	2 x 10 <sup>7</sup> switching cycles
<b>Transfer characteristics</b>	
Deviation	
After calibration	<u>Pt100</u> : ± (0.01 % of abs. temperature value of switching point in K + 0.2 K), (4-wire connection) <u>thermocouple</u> : ± (0.05 % of abs. temperature value of switching point in K + 1.1 K (1.2 K for thermocouple types R and S) this includes ± 0.8 K error of the cold junction compensation (+0.9 K for thermocouple types R and S). <u>voltage source</u> : ± (0.02 % of 10 V measuring range + 500 μV) <u>current source</u> : ± (0.02 % of 20 mA measuring range + 1 μA)
Influence of ambient temperature	<u>Pt100</u> : ± (0.0015 % of abs. temperature value of switching point in K + 0.01 K) / KΔT <sub>amb</sub> <sup>*)</sup> <u>thermocouple</u> : ± (0.004 % of abs. temperature value of switching point in K + 0.01 K) / KΔT <sub>amb</sub> <sup>*)</sup> <u>thermocouple type R and S</u> : ± (0.005 % of abs. temperature value of switching point in K + 0.01 K) / KΔT <sub>amb</sub> <sup>*)</sup> <u>voltage source</u> : ± (0.007 % of the switching point voltage) / KΔT <sub>amb</sub> <sup>*)</sup> <u>current source</u> : ± (0.0055 % of the switching point current) / KΔT <sub>amb</sub> <sup>*)</sup> <sup>*)</sup> ΔT <sub>amb</sub> = ambient temperature change referenced to 23 °C (296 K)
Influence of supply voltage	<u>Pt100, Ni100, thermocouples</u> : <u>10 V voltage source</u> : ≤ 0.001 % of span <u>20 mA current source</u> : ≤ 0.0035 % of span
Input delay	≤ 370 ms (rise time and energizing delay of relay)
<b>Electrical isolation</b>	
Input/output	safe electrical isolation acc. to EN 50020, voltage peak value 375 V
Input/power supply	safe electrical isolation acc. to EN 50020, voltage peak value 375 V
Output/power supply	acc. to VDE 0106, part 101 safety isolated, rated insulation voltage 253 V <sub>eff</sub>
<b>Standard conformity</b>	
Insulation coordination	acc. to DIN EN 50178
Electrical isolation	acc. to DIN EN 50178
Electromagnetic compatibility	acc. to EN 50081-2 / EN 50082-2, NAMUR NE 21
Climatic conditions	acc. to DIN IEC 721
<b>Ambient conditions</b>	
Ambient temperature	-20 ... 60 °C (253 ... 333 K)
<b>Mechanical specifications</b>	
Protection degree	IP20
Mass	approx. 150 g
<b>Data for application in conjunction with hazardous areas</b>	
Supply	
Safety maximum voltage U <sub>m</sub>	40 V DC
Electrical isolation	
Input/output	safe electrical isolation acc. to EN 50020, voltage peak value 375 V

**Function**

The trip amplifiers are used with Pt100 and/or thermocouples. In addition, inputs for current/voltage unit signals are available. The parameterisation is accomplished with K-ADP1 adapter and a PC. The user interface meets

Release date 2009-07-02 17:00 Date of issue 2009-07-02 07:2159\_ENG.xml

VDI/VDE GMA 2187. The input is galvanically isolated from the output, the programming input and the power supply.

The PC's serial interface is galvanically isolated from the programming input by connecting the K-ADP1 adapter. Programming can occur during operation and with a connected Ex-circuit.

The internal or external cold junction compensation options can be selected when using thermocouples.

The K-CJC-GN terminal is available for internal compensation.

The action taken during error conditions can be adjusted at the switch outputs. A fault is indicated by a red flashing LED per NAMUR NE 44.

## Notes

**Accessories** (see section Accessoires and Installation Techniques)