



- 24 V DC supply voltage
- Device installation permissible in zone 2
- Supply current  $\leq 2$  A
- Bus access via terminals
- Redundant supply
- Fault signal output with adjustable mode of operation
- EMC acc. to NAMUR NE 21

**redundant supply**  
**KFD2-EB.D2A.B**

**Function**

The power feed module supplies the Power Rail with a voltage of 24 V DC and a maximum current of 2 A.

The integrated error evaluation system detects fuse errors and possible collective error messages. In a fault condition, the relay switches (normally open contact terminals 7 and 10) and the malfunction is indicated by means of the red LED on the front. The mode of operation can be adjusted with a plug-in jumper.

Terminals 13 and 15 are used for the bus connection (only for Power Rail PR-05 or UPR-05).

Terminal 14 is the measuring point for the collective error message (only provided for test purposes, must not be wired into the system).

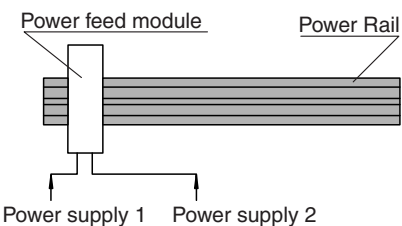

Two power supplies can be used with **one** power feed module as a redundant power supply on a Power Rail.

**Connection**

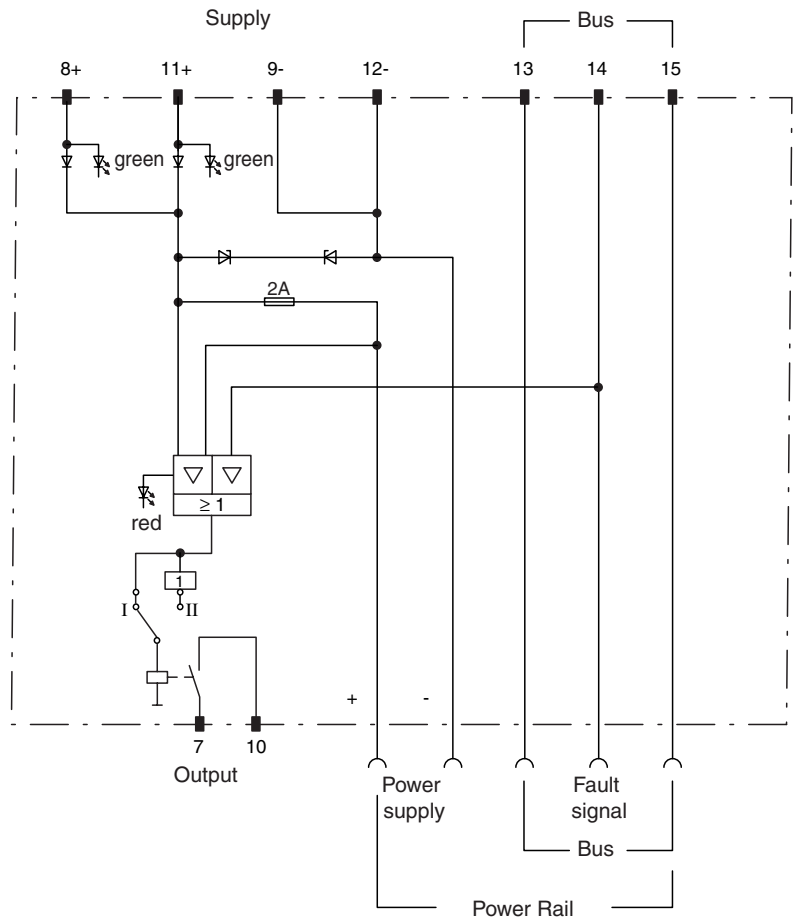

**Composition**

**Front View**

Housing type C2  
(see system description)

LED red:  
Fault signal

LED green:  
Power supply

LED green:  
Power supply

Removable terminals  
green



<b>Supply</b>	
Connection	terminals 11+, 12- terminals 8+, 9-
Rated voltage	20 ... 30 V DC The maximum rated operational voltage of the devices plugged onto the Power Rail must not be exceeded.
Power loss	2.4 W
<b>Output</b>	
Power Rail feed	output current: $\leq 2$ A
Fault signal	relay output: NO
Contact loading	24 V AC, 2 A / 24 V DC, 2 A
Energized/De-energized delay	approx. 20 ms / approx. 20 ms
<b>Conformity</b>	
Protection degree	IEC 60529
<b>Ambient conditions</b>	
Ambient temperature	-25 ... 60 °C (248 ... 333 K)
<b>Mechanical specifications</b>	
Protection degree	IP20
Mass	approx. 100 g
Dimensions	20 x 118 x 115 mm (0.8 x 4.6 x 4.5 in)
<b>Data for application in conjunction with hazardous areas</b>	
Statement of conformity	TÜV 00 ATEX 1618 X , observe statement of conformity
Group, category, type of protection, temperature classification	⊕ II 3 G EEx nAC IIC T4
<b>Entity parameter</b>	
Certification number	J.I.3000847
FM control drawing	No. 116-0160
Suitable for installation in division 2	yes
<b>Safety parameter</b>	
CSA control drawing	LR 36087-18
Control drawing	No. 116-0149

Supplementary information

Statement of Conformity, Declaration of Conformity and instructions have to be observed. For information see [www.pepperl-fuchs.com](http://www.pepperl-fuchs.com).

Notes

Adjustment of the jumpers

Power Rail supply and bus

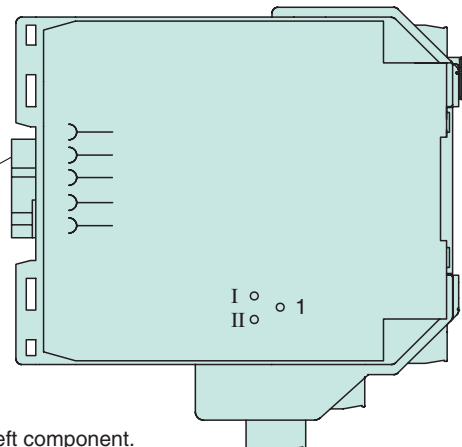

The jumper is visible on the circuit board after removing the cover and the left component.