

Features

- 1-channel isolated barrier
- 24 V DC supply (Power Rail)
- Dry contact or NAMUR inputs
- Relay contact and active transistor output
- Line fault detection (LFD)
- Reversible mode of operation

Function

This isolated barrier is used for intrinsic safety applications. It transfers digital signals (NAMUR sensors/mechanical contacts) from a hazardous area to a safe area.

The proximity sensor or switch controls a form C changeover relay contact and an active transistor for the safe area load. The normal output state can be reversed using switch S1a. Switch S1b is used to enable or disable line fault detection of the field circuit.

During an error condition, the relay and transistor revert to their de-energized state and the LEDs indicate the fault according to NAMUR NE44.

Assembly

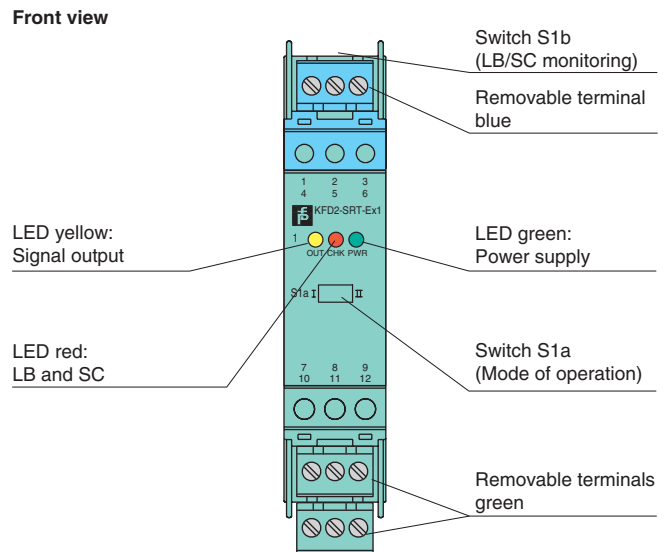

Connection

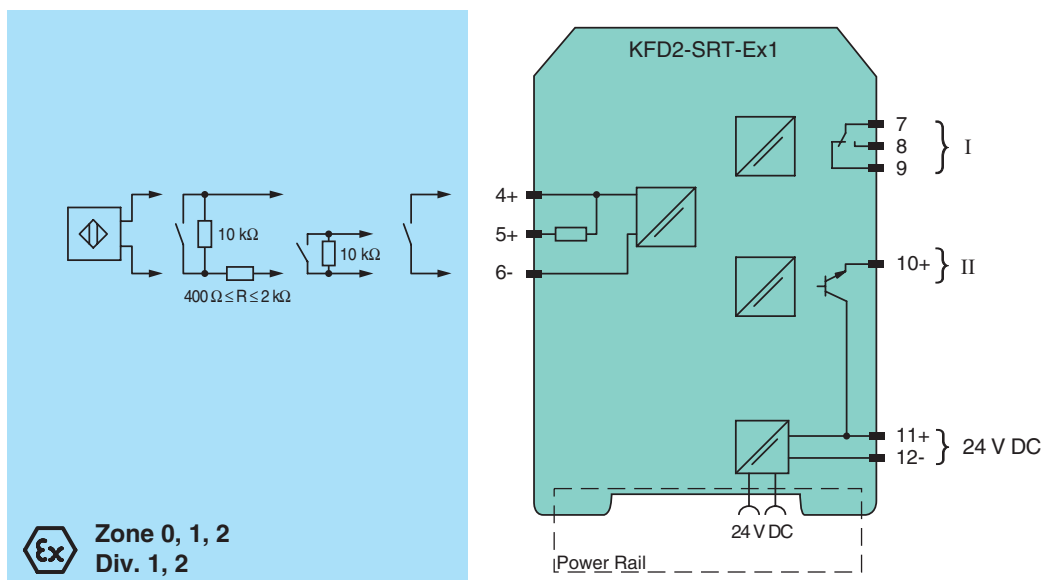

Release date 2010-02-02 14:13 Date of issue 2010-02-02 034782_ENG.xml

General specifications		
Signal type		Digital input
Supply		
Connection		Power Rail or terminals 11+, 12-
Rated voltage		20 ... 35 V DC
Ripple		≤ 10 %
Rated current		30 mA
Power loss		0.7 W
Input		
Connection		terminals 4+, 5+, 6-
Rated values		acc. to EN 60947-5-6 (NAMUR), see system description for electrical data
Open circuit voltage/short-circuit current		approx. 8 V DC / approx. 8 mA
Switching point/switching hysteresis		1.2 ... 2.1 mA / approx. 0.2 mA
Pulse/Pause ratio		≥ 20 ms / ≥ 20 ms
Line monitoring		breakage I ≤ 0.1 mA , short-circuit I > 6 mA
Output		
Connection		output I: terminals 7, 8, 9 ; output II: terminals 10
Output I		signal ; relay
Output II		signal ; electronically active
Contact loading		253 V AC/ 2 A / cos φ > 0.7 ; 40 V DC/ 2 A resistive load
Mechanical life		10 ⁷ switching cycles
Energized/de-energized delay		approx. 20 ms / approx. 20 ms
External supply (loop)		
Signal level		1-signal: (L+) -3.5 V (current 100 mA, short-circuit proof) / 0-signal: switched off (off-state current ≤ 10 μA)
Transfer characteristics		
Redundancy		
Output I		≤ 25 Hz
Output II		≤ 1 kHz
Electrical isolation		
Output/power supply		basic insulation according to IEC 61140, rated insulation voltage 50 V _{eff}
Output/output		basic insulation according to IEC 61140, rated insulation voltage 50 V _{eff}
Directive conformity		
Electromagnetic compatibility		
Directive 2004/108/EC		EN 61326-1:2006
Low voltage		
Directive 2006/95/EC		EN 50178:1997
Ambient conditions		
Ambient temperature		-20 ... 60 °C (253 ... 333 K)
Mechanical specifications		
Protection degree		IP20
Mass		approx. 150 g
Dimensions		20 x 107 x 115 mm (0.8 x 4.2 x 4.5 in) , housing type B1
Data for application in conjunction with hazardous areas		
EC-Type Examination Certificate		PTB 00 ATEX 2082 , for additional certificates see www.pepperl-fuchs.com
Group, category, type of protection		Ⓔ II (1)GD [EE ia] IIC [circuit(s) in zone 0/1/2]
Input		EE ia IIC
Voltage	U _o	12.7 V
Current	I _o	20 mA
Power	P _o	62 mW (linear characteristic)
Supply		
Safety maximum voltage U _m		253 V AC / 125 V DC (Attention! U _m is no rated voltage.)
Output		
Contact loading		253 V AC/4 A/cos φ ≥ 0.7; 40 V DC/0.5 A resistive load
Safety maximum voltage U _m		253 V AC (Attention! The rated voltage can be lower.)
Electrical isolation		
Input/output		safe electrical isolation acc. to EN 50020, voltage peak value 375 V
Input/power supply		safe electrical isolation acc. to EN 50020, voltage peak value 375 V
Directive conformity		
Directive 94/9/EC		EN 50014, EN 50020
International approvals		
FM approval		
Control drawing		116-0035
CSA approval		
Control drawing		116-0047

Release date 2010-02-02 14:13 Date of issue 2010-02-02 034782_ENG.xml

General information	
Supplementary information	EC-Type Examination Certificate, Statement of Conformity, Declaration of Conformity, Attestation of Conformity and instructions have to be observed where applicable. For information see www.pepperl-fuchs.com .

Configuration

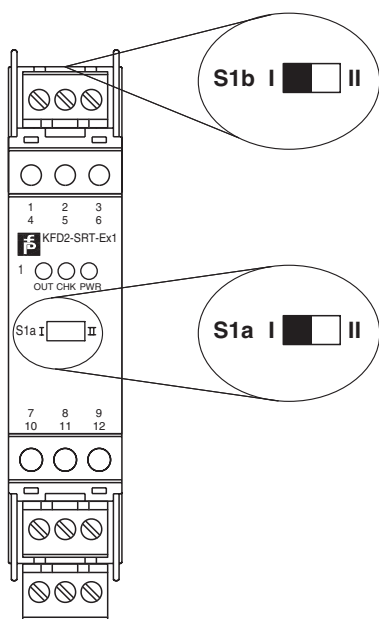

Switch position

S	Function		Position
1a	Mode of operation active	with high input current	I
		with low input current	II
1b*	Line fault detection	ON	I
		OFF	II

* Installation position below the terminals

Operating status

Control circuit	Input signal
Initiator high impedance/ contact opened	low input current
Initiator low impedance/ contact closed	high input current
Lead breakage, lead short-circuit	Line fault

Accessories

Power feed modules KFD2-EB2...

The power feed module is used to supply the devices with 24 V DC via the Power Rail. The fuse-protected power feed module can supply up to 100 individual devices depending on the power consumption of the devices. A galvanically isolated mechanical contact uses the Power Rail to transmit collective error messages.

Power Rail UPR-03

The Power Rail UPR-03 is a complete unit consisting of the electrical inset and an aluminium profile rail 35 mm x 15 mm. To make electrical contact, the devices are simply engaged.

The Power Rail must not be fed via the device terminals of the individual devices!