



EEx & Industrial Switches & Sensors

- EEx Position (Limit) Switches for explosive gases & dusts
- EEx Proximity Switches
- Industrial Position (Limit) Switches
- Industrial Proximity Switches



AUDIN

Composants & systèmes d'automatisme
8, avenue de la malle - 51370 St Brice Courcelles
Tel. +33(0)326042021 • Fax +33(0)326042820
<http://www.audin.fr> • e-mail info@audin.fr

**Rockwell
Automation**

Safety Products also available:



Also available under the Allen-Bradley Guardmaster brand is a comprehensive range of Safety Products for machinery safeguarding including:

Interlock Switches

- Tongue Operated Interlock Switches
- Hinge Operated Interlock Switches
- Non Contact Interlock Switches
- Guard Locking Interlock Switches
- Position (Limit) Switches

Safety Relays

- Quick Reference Guide
- Safety Relays
- Modular Safety Relays - MSR200
- Control Units

Emergency Stop Devices

- Cable Pull Switches
- Rope Tensioner Kit

Trapped Key Interlock Switches

- Principles & Overview
- Electrical Isolators & Timers
- Key Exchange Units
- Interlocks

Presence Sensing Safety Devices

- Safety Light Curtains & Scanners
- Safety Light Curtain Control Units
- MatGuard - Pressure Sensitive Mat System
- Safedge - Pressure Sensitive Edge System

For more information:

www.ab.com/safety or www.ejaltd.co.uk
or contact your local supplier.

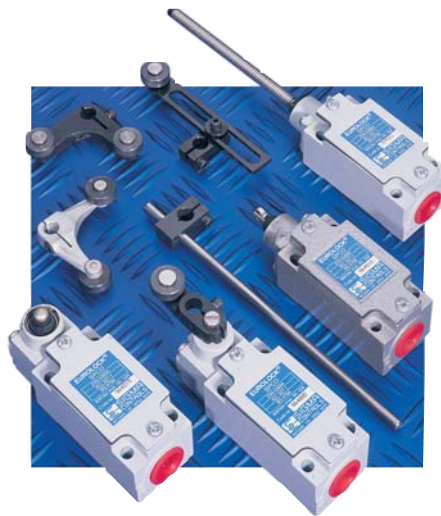
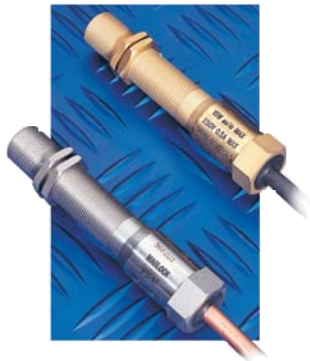

Content

EEx & industrial switches & sensors

Introduction & principles of operation	2
EEx limit, proximity switches & sensors	
For explosive gases and dusts	
Eurolock	7
For explosive gases & mines	
Snaplock 615	8
For explosive gases	
MPS 24D, 26D, 34D & 36D	10
ES 24T, 24TH, 34T, 34TH & 34TI	11
Intrinsically Safe	
MPS 44	12
MPS I	13
MPS 3i, ES 2i, ES 3i	14
Industrial switches & sensors	
MPS 3	16
MPS 16	17
MPS 2, 12 & 14	18
ESI & ES2	19
MPS 1/1 & 1/5	20
MPS 5 & 15	21
MPS V1, V3 & V4	22
Snaplock 600 series	23
Eurolock	24
Microlock	25
Securilock	26
Magnetic actuators & spacers	27

Explosion Proof & Industrial switches

Sigma Controls Ltd manufactures switches, sensors, valve position indicators and systems for the control and monitoring of machinery, vehicles and processes. It has a long established reputation as one of the leading producers of explosion proof and intrinsically safe devices for use in hazardous atmospheres.

Sigma switches and sensors are manufactured at our modern factory where all the necessary facilities for development, manufacturing, testing and shipping are present in strength. The Sigma switch division retains all the expertise gleaned from years of switch development, particularly in the field of BASEEFA approved explosion proof switches. This knowledge has been combined with the experience and resources of the EJA Engineering Group to form a cohesive and powerful manufacturing facility capable of meeting the requirements of industry into the next century.

This section is intended to show the basic range of Sigma devices. If the type of device you require is not illustrated, please contact us, we also produce a range of "non standard" equipment of too great a variety to include in this publication. Any special requirements for unusual or demanding applications can normally be satisfied and our design team are always happy to discuss any particular needs.

Sigma switches and sensors have been used for many years in some of the most demanding and critical applications such as the petrochemical, mining and nuclear industries. Within these sectors, where safe and reliable operation is paramount, they are highly regarded for their total dependability and strength. In these industries there is no room for failure. Sigma Controls are continuously seeking to develop new solutions and to reach new markets wherever quality and reliability are a prerequisite.

There is a variety of devices in this publication, from the massive and rugged Snaplock 615 limit switch capable of operating safely and reliably in the aggressive environment of the coal industry, to the diminutive Securilock which can be discreetly mounted to provide a highly sensitive and tamper proof security sensor. They may differ greatly in their type and application but they all have one factor in common, total quality assurance, If its Sigma its safe.

Applications

Sigma switches and sensors have extensive and diverse applications which include areas such as:

- Machinery control.
- Security arrangements - Doors, windows etc.
- Luffing and slewing controls for mobile cranes.
- Position indication on pipeline valves.
- Gasometer height control.
- Levelling of lifts at desired floor level.
- Component position sensing on mass production conveyor systems.
- Switching of electro-mechanical or solid state counters.
- Various industrial control applications.
- Door position sensing for public transport vehicles.

Explanation of marking of EEx equipment

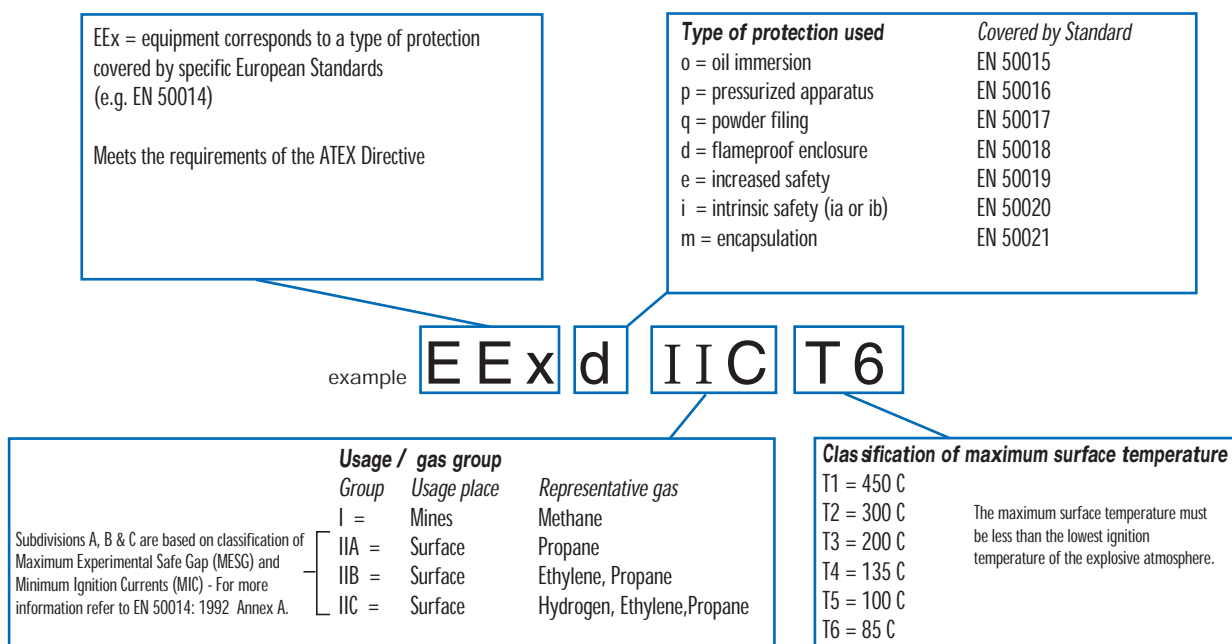



Sigma switches and sensors are used extensively in the public transport industry. Due to their ability to withstand extreme usage they are used for door position sensing on some of the worlds busiest commuter services.



Sigma switches and sensors are used throughout industry. Many of the devices combine EEx characteristics with virtually indestructible bodies made from stainless steel, mazak or aluminium. This makes them ideal for use in industries such as petrochemicals and nuclear power for duties such as valve position indication.



In this application Sigma Eurolock switches are combined with extra long flexible antennae to provide accurate position sensing for an airliner de-icing process. This is just one example from a vast number of diverse applications where the unique characteristics of Sigma switches mean they are the best (and sometimes only) choice.

general introduction

SIGMA limit and proximity switches are available in two basic types of devices:

EEx devices

These devices are suitable for use in explosive or potentially explosive atmospheres.

Industrial devices

Those suitable for general or heavy duty usage but not suitable for use in explosive or potentially explosive atmospheres.

The following pages cover the various ranges of SIGMA limit and proximity switches and give information required for selection of the correct switch device for a given application. However, the SIGMA MAGLOCK range of magnetic and ferrous actuated proximity switches covers a wide variety of devices. The selection of a suitable MAGLOCK switch and actuator depends upon a brief knowledge of Maglock proximity switching techniques. Relevant details are given here.

Maglock proximity switching techniques

magnetically actuated switches

In all magnetic switch applications the switch and actuator must be brought together to within a specific proximity or operating distance of each other. The actual distance involved in a particular case will depend upon their relative attitudes, sensitivity and direction of closing. When the actuator (magnet) is brought close enough the switch will operate and when it is withdrawn the switch resets itself. The gap between the switch and the actuator when the switch operates is always less than the gap at which the switch resets itself, the difference between the two being referred to as the 'operating differential'. The principle actuation situations are discussed in the succeeding paragraphs together with other relevant factors.

perpendicular movement

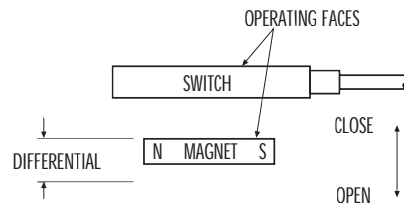

In this situation the operating faces (those with the labels attached - except MPS1 and MPS21, approach and withdraw from each other perpendicularly. This is the most widely adopted method of actuation.

pivoting movement

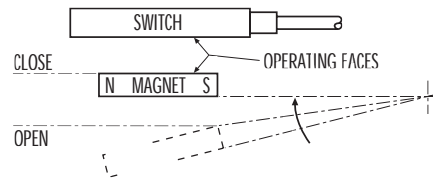

This movement is similar to the perpendicular movement previously described but due to the angle of approach and withdrawal the operating differential is greater.

rotary movement

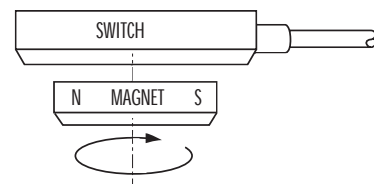

Aligning the switch and magnetic actuator opposite each other (similar to perpendicular operation) and then rotating the magnet will result in two switch operations per revolution.

parallel movement across the width of the switch

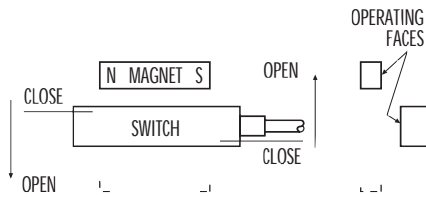

In this case the face of the magnet slides across the face of the switch with a constant distance between them, the direction of movement being across the width of the components rather than lengthwise. As the switch is approached by the magnet it will operate. Continued movement to a given point will result in the switch resetting itself. The same sequence and relative positions of operation and reset will occur if the magnet is now moved across the switch in the reverse direction.

parallel movement along the length of the switch

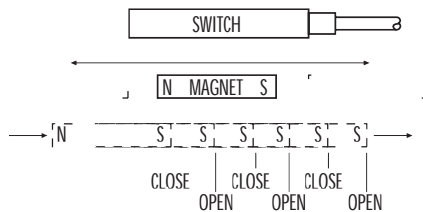

This movement is similar to the parallel movement across the component widths, the difference being that sliding the components past each other lengthwise results in a number of switch operations taking place during a complete traverse. This method is not recommended unless travel is limited such that only one cycle of operation occurs, i.e. one operation and reset, either by mechanical limitation or adjustment of the gap between the switch and the path of actuator travel such that the magnetic field is weakened to allow only one cycle of operation to occur.

magnetic centre

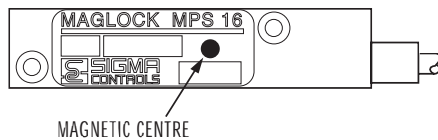

The magnetic centre of a Maglock switch or actuator is denoted by a symbol on the operating face as indicated in the diagram.

magnetic centre

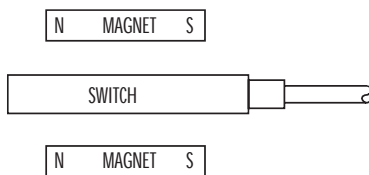

It may be desirable in some instances to change the basic operating mode of a switch, i.e. a normally open switch may need converting to a normally closed switch to suit a particular application. This is normally achieved by means of magnetic biasing whereby a permanent magnet is situated close enough to a normally open switch to maintain its contacts in a closed position. The approach of a normal magnetic actuator will effectively cancel the influence of this additional magnet and return the switch to its original position.

ferro-actuated switches

The fundamental difference between a Maglock magnetically actuated switch and a ferro-actuated switch is that the latter has a 'built-in' system of permanent magnets. Whereas the magnetically actuated switch requires the approach of an external permanent magnet actuator before it will operate, the ferro-actuated version operates upon the approach of a simple piece of ferro-magnetic material, e.g. mild steel. The effect of the ferro-magnetic material is to modify or shunt a part of the internal magnetic field surrounding the switch contacts, thus allowing the switch to operate.

There are two basic types of ferro-actuated switch. One type relies on the basic principles outlined in the previous paragraph which are akin to the magnetic biasing techniques described for certain magnetically actuated switch applications. The other type, a vane switch, operates when a ferro-magnetic sheet or vane is inserted into the switch body itself, the vane once again acting as magnetic shunt or shield but more in the form of an internal separator than an external biasing force.

parallel movement along the length of the switch

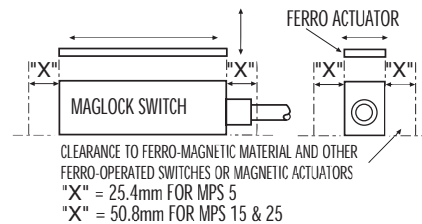

These switches are operated by the external approach of a ferrous actuator as shown in the diagram.

magnetic centre

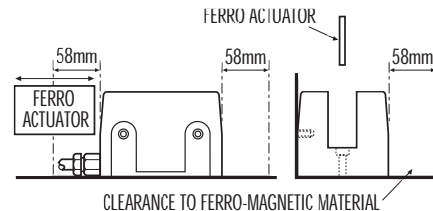

These switches are operated by passing a ferrous vane through a slot in the body of the switch, the effect of the vane being to temporarily shield the contacts on one side of the switch from the influence of the permanent magnet system incorporated in the other side, thus allowing the contacts to operate. Removal of the vane allows the magnetic circuit to re-establish itself and return the switch to its initial state.

testing Maglock switches

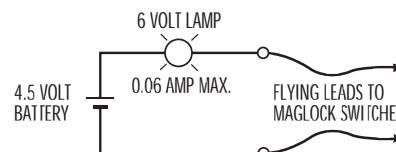

When testing Maglock switches a simple lamp test circuit should be used as shown above or an ohm meter. On no account use 'bell' test sets.

testing Maglock switches

The life of the reeds used in magnetic reed switches can be greatly reduced if subjected to capacitive loads. An often overlooked source of such loads is cable capacitance in long cable runs. The damage is caused by the high current surge experienced with this type of load when the reed contacts close. If this is likely to be a problem the simplest form of protection is a resistor wired in series with the switch as close to it as possible. The resistors value should be sufficient to limit the current surge within the operational ratings of the switch being used.



EEx limits & proximity switches

EEx limit switches

EEx proximity switches

EEx end sensors



technical specifications

Contact arrangement	C/O single pole (change over) snap acting
Contact material	Silver
Max volts	250V ac/dc
Max current	5A ac / 0.25A dc
Case material	Mazak
Protection	Contact block IP66, housing IP65
Operating temperature	-25°C to +70°C
Mechanical life	2 x 10 ⁶ typical
Electrical life	Subject to switched load
Cable	Pre-wired with 3m cable
Connections	N/O black & black, N/C blue & brown
Conforms to standards	EN 50014, EN 50018 DIN 43694, EN 50041 BS EN 60204-1
Certification	EExd IIC T6 PTB00ATEX 1093X

EEx limit switches
eurolock

- Snap acting EEx contact block
- Roller, plunger or lever actuation
- Conforms to DIN 43694, EN 50041
- Contact block IP66, housing IP65

dimensions & ordering details

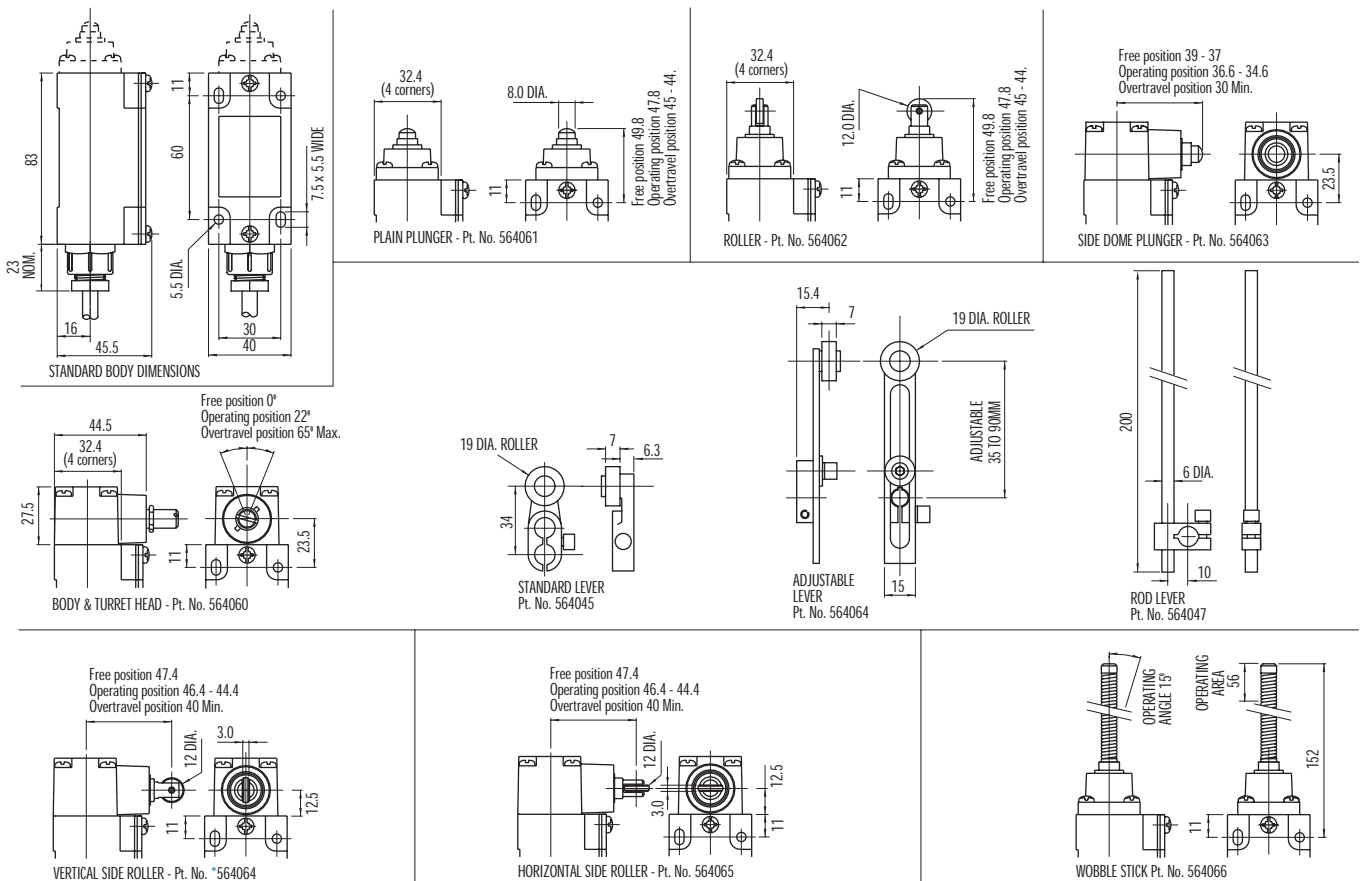



technical specifications

Contact arrangement	See ordering details
Contact material	Silver (other materials available)
Case material	Cast iron
Protection	IP65 (IP66 with Hylomar compound applied to mating faces)
Operating temperature	-20°C to +40°C
Mechanical life	10 x 10 ⁶ typical
Electrical life	Subject to switched load
Weight	6Kg
Conforms to standards	
Groups I & II	EN 50014, EN 50018 BS EN 60204-1
Certification	
Group I	Baseefa 03ATEX 0139X
Group II	Baseefa 03ATEX 0140X

EEx limit switches
Snaplock 615

- BASEEFA certified
- Available in Group I or Group II versions
- High grade cast iron housing
- Extra heavy duty

MINES

Must be used with a suitable certified cable entry device, (with or without the interposition of a suitable certified flameproof thread adaptor) or suitable certified stopping plugs where appropriate.

The flameproof cable entry devices, thread adaptors and stopping plugs must be certified as equipment (not a component) under an EC type examination certified to Directive 94/9/EC.

The cable entry devices and cabling methods used in service must be suitable for their intended duty and special types of cable used in Mining.

Must not be dismantled whilst energised or when an explosive gas is present.

Care must be taken not to damage the flamepaths during installation and maintenance.

GROUP 2 GASES

Must comply with the installation requirements as specified in BS60079-14:1997

Must be used with suitable Baseefa certified cable entry devices, or with or without the interposition of a suitable Baseefa certified flameproof thread adaptor.

Suitable flameproof cable entry devices, thread adaptors and stopping plugs certified as equipment (not a component) under an EC type examination certified to Directive 94/9/EC may also be used in the manner specified above.

Must not be dismantled whilst energised or when an explosive gas is present.

Care must be taken not to damage the flamepaths during installation and maintenance.

dimensions

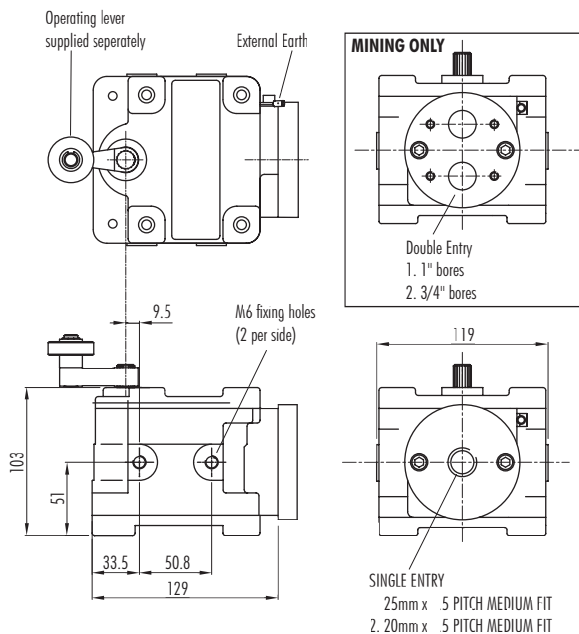

LEVERS

Switches and levers are supplied separately. A small selection of levers is shown here. Please contact us for details of other types.

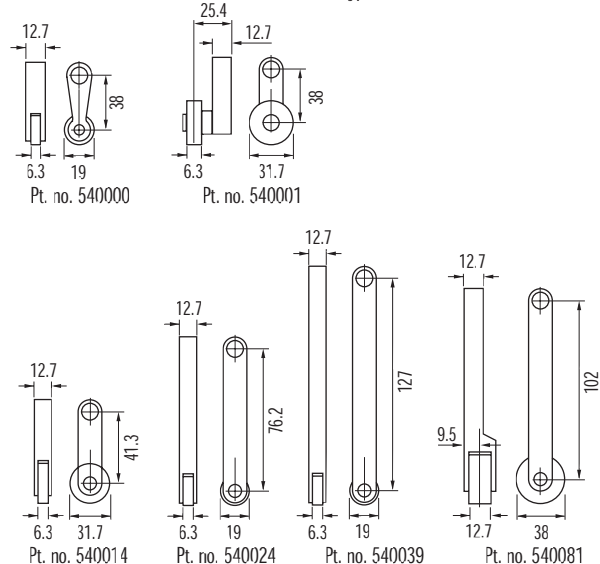

electrical ratings

Table 1 - Types 'SL' & 'SLNP'

CURRENT RATINGS	Ampere Ratings AC Circuit						Ampere Ratings DC Circuit					
	240V		440V		550V		115V		330V		550V	
	Single Circuit	Double Circuit	Single Circuit	Double Circuit	Single Circuit	Double Circuit	Single Circuit	Double Circuit	Single Circuit	Double Circuit	Single Circuit	Double Circuit
INRUSH	20	20	20	20	20	20	-	-	-	-	-	-
CONTINUOUS CAPACITY	10	10	10	10	10	10	10	10	10	10	10	10
RUPTURING CAPACITY (NON INDUCTIVE)	10	10	7.5	7.5	5	5	5	5	2	1	0.5	0.25
RUPTURING CAPACITY (INDUCTIVE)	10	10	7.5	7.5	5	5	5	1	1	0.5	0.25	0.13

Table 2 - Types 'SPS'

CURRENT RATINGS	VOLTS	AMPS
AC (RMS)	240	5 Resist
DC	Not Recommended	

Table 3 - Types 'SPCO', 'DPTS' & 'DP' - Group II Gases

CURRENT RATINGS	120V		240V		480V		VA	
	Make	Break	Make	Break	Make	Break	Make	Break
AC	60A	6A	30A	3A	15	1.5A	7200	720
	Continuous carrying current 10A							
	Make or Break Ratings							
DC	125V		250V		480V		VA < 300V	
	0.55A		0.27A		0.10A		69	
	Continuous carrying current 2.5A							

Table 4 - Types 'SPCO' - Mining

CURRENT RATINGS	120V		240V	
	Make	Break	Make	Break
AC	60A	6A	30A	3A
	Continuous carrying current 10A			
	Make or Break Ratings			
DC	125V		250V	
	0.55A		0.27A	
	Continuous carrying current 2.5A			

Table 5 - Types 'DPCO' & 'DPTS' - Mining

CURRENT RATINGS	120V	
	Make	Break
AC	5A	5A
	Continuous carrying current 10A	
	Make or Break Ratings	
DC	120V	
	0.55A	
	Continuous carrying current 2.5A	

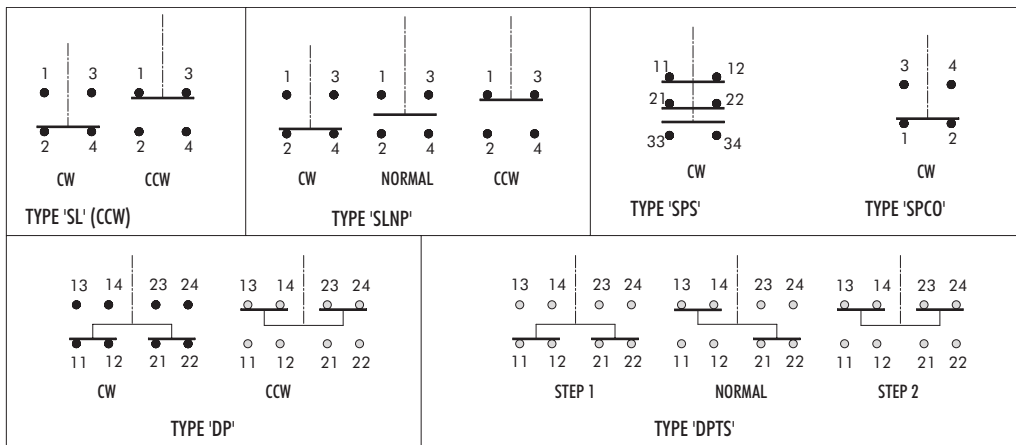

ordering details

Switch type	Contact arrangement	Part No's.					
		GROUP 1				GROUP 2	
		Single entry 20mm	Threaded gland 25mm	Double entry 3/4"	Spigotted gland 1"	Single entry 20mm	Threaded gland 25mm
SL	SP, 1N/C, 1N/O	561061	561150	561076	561151	561500	561520
SLNP	SP, 2N/O	561111	561162	561126	561163	561503	561523
SPS	SP, 1N/C, 1N/O	561174	561176	561175	561177	561506	561526
SPCO	SP, CO	561180	561182	561181	561183	561508	561528
DPCO	DP, CO	561192	561194	561193	561195	561511	561531
DPTS	DP, 2N/O, 2N/C	561186	561188	561187	561189	561515	561530

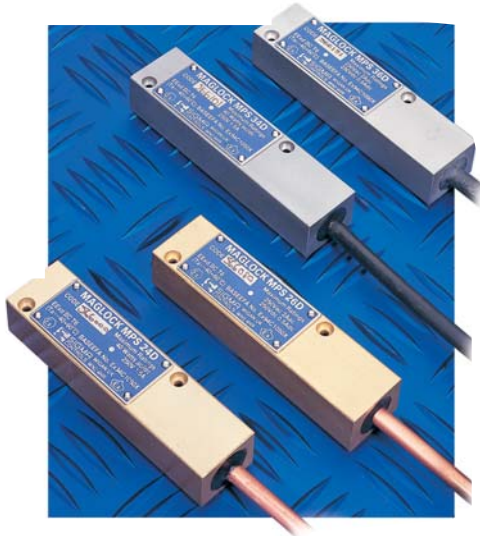

technical specifications

<p>Contact arrangement (MPS 24D, 24DH, 34D, 34DH, 34D-1) (MPS 26D, 26DH, 36D, 36DH, 36D-1)</p> <p>Contact material (MPS 24D, 24DH, 34D, 34DH, 34D-1) (MPS 26D, 26DH, 36D, 36DH, 36D-1)</p> <p>Case material Protection</p> <p>Operating temperature (MPS 24D, 26D, 34D, 36D) (MPS 24DH, 26DH, 34DH, 36DH) (MPS 34D-1 & 36D-1)</p> <p>Fixings</p> <p>Contact operating distance</p> <p>Mechanical life</p> <p>Electrical life</p> <p>Cable (MPS 24D, 24DH) (MPS 26D, 26DH) (MPS 34D, 34DH) (MPS 34D-1) (MPS 36D, 36DH) (MPS 36D-1)</p> <p>Connections (MPS 24D, 24DH) (MPS 34D, 34DH) (MPS 34D-1)</p> <p>Weight (MPS 34 & 36) (MPS 24 & 26)</p> <p>Conforms to standards</p> <p>Certification (MPS 24D, 26D, 34D & 36D) (MPS 24DH, 26DH, 34DH & 36DH) (MPS 34D-1 & 36D-1)</p>	<p>C/O single pole (change over) N/C single pole (power reed)</p> <p>Tungsten or Rhodium Silver alloy</p> <p>Brass or stainless steel IP 68 (water/oil/dust)</p> <p>-40°C to +60°C -40°C to +125°C -20°C to +60°C</p> <p>2 x M3 See page 27</p> <p>500 x 10⁶ typical Subject to switched load</p> <p>3m MICC 3L1.5 (optional PVC sheath) 3m MICC 2L2.5 (optional PVC sheath) 3m Polyolefin 3 core copper braided 3m flexible PVC 3 core 3m Polyolefin 2 core copper braided 3m flexible PVC 2 core</p> <p>Cores unmarked. Use circuit tester. N/O black & white, N/C red & white. N/O black & blue, N/C black & brown</p> <p>0.8Kg 1Kg</p> <p>EN 50014, EN 50018 BS EN 60204-1</p> <p>EExd IIC T6 (Ta= -40+60°C) EExd II T3 (Ta= -40+125°C) EExd II T6 (Ta= +60°C) Certification No. Baseefa 02ATEX 0183X</p>
--	--

**EEx proximity switches
MPS 24D, 26D, 34D, 36D**

- BASEEFA certified
- Magnetically actuated
– See page 27 for actuators (supplied separately)
- Choice of brass or stainless steel housings
- Water, oil and dustproof to IP68
- MPS 24's & 34's for resistive or solid state circuits
MPS 26's & 36's for direct switching of inductive circuits

dimensions

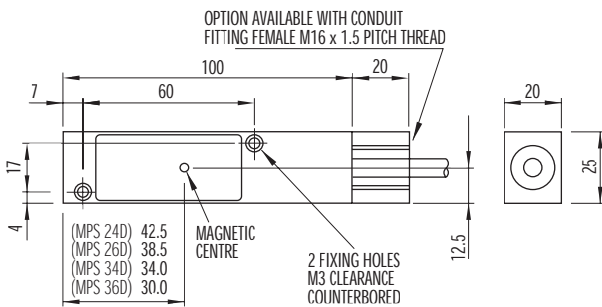

Special conditions for use relevant to certification No. Baseefa 02ATEX 0183X

Must comply with the installation requirements as specified in BS60079-14:1997

The remote end of the integral cable must be terminated in a connection facility suitable for the conditions of use.

MPS34D, 34H, 36D and 36DH. Earthing should be provided by connection of a braid of the cable or by the mounting to adjacent metal work.

MPS24D, 24HD, 36D and 36HD. Earthing should be made to the sheath of the MICC or by the mounting to adjacent metal work.

MPS34D-1 and 36D-1. Earthing should be provided by the mounting to adjacent metal work.

ordering details

Switch	Contact material	Max. volts	Max. current	Power	Part No. Brass	St. steel
MPS 24D	Tungsten	250V ac/dc	1.5A ac/dc	40W/VA (3W/VA min)	566000	566001
	Rhodium	250V ac/dc	0.5A ac/dc	15W/VA	566010	566011
MPS 24DH	Tungsten	250V ac/dc	1.5A ac/dc	40W/VA (3W/VA min)	566002	566003
	Rhodium	250V ac/dc	0.5A ac/dc	15W/VA	566012	566013
MPS 26D	Silver alloy	250V ac/dc	2A ac, 0.5A dc	500VA (ac), 125W (dc)	566050	566051
MPS 26DH	Silver alloy	250V ac/dc	2A ac, 0.5A dc	500VA (ac), 125W (dc)	566052	566053
MPS 34D	Tungsten	250V ac/dc	1.5A ac/dc	40W/VA (3W/VA min)	566100	566101
	Rhodium	250V ac/dc	0.5A ac/dc	15W/VA	566110	566111
MPS 34DH	Tungsten	250V ac/dc	1.5A ac/dc	40W/VA (3W/VA min)	566102	566103
	Rhodium	250V ac/dc	0.5A ac/dc	15W/VA	566112	566113
MPS 34D-1	Tungsten	250V ac/dc	1.5A ac/dc	40W/VA (3W/VA min)	566104	566105
	Rhodium	250V ac/dc	0.5A ac/dc	15W/VA	566114	566115
MPS 36D	Silver alloy	250V ac/dc	2A ac, 0.5A dc	500VA (ac), 125W (dc)	566150	566151
MPS 36DH	Silver alloy	250V ac/dc	2A ac, 0.5A dc	500VA (ac), 125W (dc)	566152	566153
MPS 36D-1	Silver alloy	250V ac/dc	2A ac, 0.5A dc	500VA (ac), 125W (dc)	566154	566155

These switches require a magnetic actuator. Refer to page 27.



EEx end sensors ES24T, 24TH, 34T, 34TH, 34T1

- BASEEFA certified
- End sensing
- Magnetically actuated
 - See page 27 for actuators (supplied separately)
- Choice of brass or stainless steel housings
- Water, oil and dustproof to IP68
- For resistive or solid state circuits

technical specifications

Contact arrangement	C/O single pole (change over)
Contact material	Tungsten or Rhodium
Case material	Brass or stainless steel
Protection	IP 68 (water/oil/dust)
Operating temperature	
(ES 24T, ES 34T)	-40°C to +60°C
(ES 24TH, ES 34TH)	-40°C to +125°C
(ES 34T1)	-20°C to +60°C
Fixings	M16 threaded housing
Contact operating distance	See page 27
Mechanical life	500 x 10 ⁶ typical
Electrical life	Subject to switched load
Cable	
(ES 24T, ES 24TH)	3m MICC 3L1.5 (optional PVC sheath)
(ES 34T, ES 34TH)	3m Polyolefin 3 core copper braided. Braid bonded to housing. (Galv. steel wire versions available)
(ES 34T1)	3m flexible PVC 3 core unbraided
(Connections)	
(ES 24T, ES 24TH)	Cores unmarked. Use circuit tester.
(ES 34T, ES 34TH)	N/O black & white, N/C red & white.
(ES 34T1)	N/O blue & black N/C brown & black
Weight	0.35Kg approx.
Conforms to standards	EN 50014, EN 50018 BS EN 60204-1
Certification	
(ES 24T, ES 34T)	EExd IIC T6 (Ta= -40+60°C)
(ES 24TH, ES 34TH)	EExd II T3 (Ta= -40+125°C)
(ES 34T1)	EExd II T6 (Ta= +60°C)
	Certification No. Baseefa 02ATEX 0183X

Special conditions for use relevant to certification No. Baseefa 02ATEX 0183X

Must comply with the installation requirements as specified in BS60079-14:1997

The remote end of the integral cable must be terminated in a connection facility suitable for the conditions of use.

ES34T and ES34TH. Earthing should be provided by connection of a braid of the cable or by the mounting to adjacent metal work.

ES24T and ES24TH. Earthing should be made to the sheath of the MICC or by the mounting to adjacent metal work.

ES34T-1. Earthing should be provided by the mounting to adjacent metal work.

dimensions

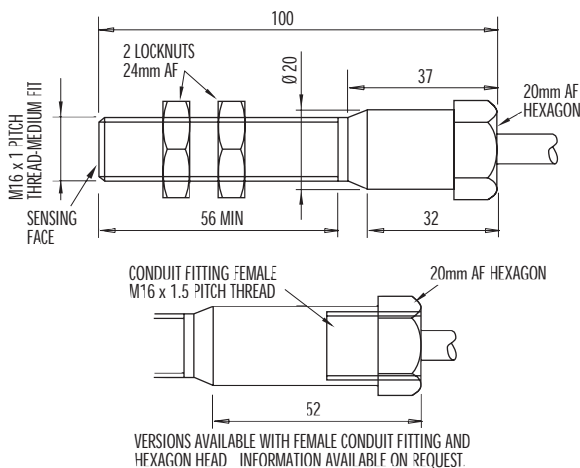

ordering details

Switch	Contact material	Max. volts	Max. current	Power	Part No. Brass	St. steel
ES 24T	Tungsten	250V ac/dc	1.5A ac/dc	40W/VA (3W/VA min)	566200	566201
	Rhodium	250V ac/dc	0.5A ac/dc	15W/VA	566210	566211
ES 24TH	Tungsten	250V ac/dc	1.5A ac/dc	40W/VA (3W/VA min)	566202	566203
	Rhodium	250V ac/dc	0.5A ac/dc	15W/VA	566212	566213
ES 34T	Tungsten	250V ac/dc	1.5A ac/dc	40W/VA (3W/VA min)	566220	566221
	Rhodium	250V ac/dc	0.5A ac/dc	15W/VA	566230	566231
ES 34TH	Tungsten	250V ac/dc	1.5A ac/dc	40W/VA (3W/VA min)	566222	566223
	Rhodium	250V ac/dc	0.5A ac/dc	15W/VA	566232	566233
ES 34T1	Tungsten	250V ac/dc	1.5A ac/dc	40W/VA (3W/VA min)	566224	566225
	Rhodium	250V ac/dc	0.5A ac/dc	15W/VA	566234	566235

These switches require a magnetic actuator. Refer to page 27.



technical specifications

Contact arrangement	C/O single pole (change over)
Contact material	Rhodium
Case material	Brass or stainless steel
Protection	IP 68 (water/oil/dust)
Operating temperature	-20°C to +40°C
Fixings	2 x M3
Contact operating distance	See page 27
Mechanical life	500 x 10 ⁶ typical
Electrical life	Subject to switched load
Cable	3m Polyolefin (braided) or 3m flexible PVC or 3m MICC
Connections	
(Polyolefin cable)	N/O black & white, N/C red & white.
(PVC cable)	N/O black & blue, N/C black & brown
(MICC cable)	Cores unmarked. Use circuit tester.
Weight	0.5Kg approx
Conforms to standards	EN 50014, EN 50020, BS EN 60204-1
Certification	EExia IIC T6 Certification No. Baseefa 02ATEX 0120X

EEx proximity switches
Intrinsically Safe MPS 44

- BASEEFA certified
- Intrinsically Safe
- Magnetically actuated
 - See page 27 for actuators (supplied separately)
- Choice of brass or stainless steel housings
- Water, oil and dustproof to IP68
- External M16 x 1.5 pitch threaded gland to accept conduit protection

The electrical circuit in the hazardous area must be capable of withstanding an a.c. test voltage of 500 volts rms to earth or frame of the apparatus for one minute.

The installation must comply with the installation requirements as specified in BS60079-14:1997.

The power source must be certified by an EEC approved body to EExia or EExib, whichever is applicable with:

- Ui max out 30V
- Ii max out 250mA
- Pi max out 1.3W

The capacitance and inductance, or inductance to resistance (L/R) ratio of the hazardous area cables must not exceed the values of the power source in use.

Safe area apparatus is unspecified except that it must not be supplied from, nor contain under normal or abnormal conditions, a source of potential with respect to earth in excess of 250 volts rms or 250 volts d.c.

Special conditions of use - the cable must be terminated in an enclosure that provides a degree of protection of at least IP 20 for the connections.

dimensions

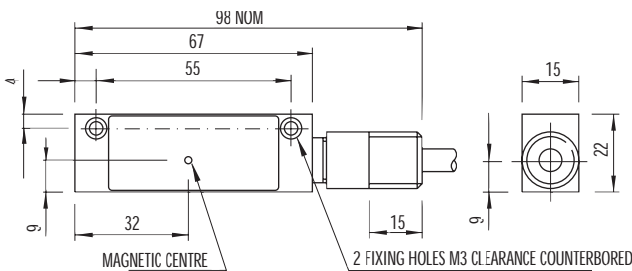

ordering details

Switch	Max. volts	Max. current	Power	Part No.	
				Brass	St. steel
MPS 44 (Polyolefin cable)	250Vdc, 150Vac	0.5A ac/dc	10Wdc, 10VAac	565252	565253
MPS 44 (PVC cable)	250Vdc, 150Vac	0.5A ac/dc	10Wdc, 10VAac	565250	565251
MPS 44 (MICC cable)	250Vdc, 150Vac	0.5A ac/dc	10Wdc, 10VAac	565254	565267

These switches require a magnetic actuator. Refer to page 27.



technical specifications

Contact arrangement	C/O single pole (change over) for resistive circuits only
Contact material	Tungsten (Rhodium available)
Case material	Aluminium or Mazak
Protection	IP 65 (water/oil/dust)
Operating temperature	-10°C to +50°C
Fixings	4 x M6
Contact operating distance	See page 27
Mechanical life	500 x 10 ⁶ typical
Electrical life	Subject to switched load
Cable entry	20mm conduit entry.
Weight	1Kg
Conforms to standards	EN50014, EN50018 EExia IIC T5 EN 60204-1
Certification	Certification No. Baseefa 02ATEX 0120X

Ex proximity switches
Intrinsically Safe MPS 1

- BASEEFA certified
- Intrinsically Safe
- Magnetically actuated
 - See page 27 for actuators (supplied separately)
- Choice of aluminium or Mazak housings
- Water, oil and dustproof to IP65
- Choice of reed positions

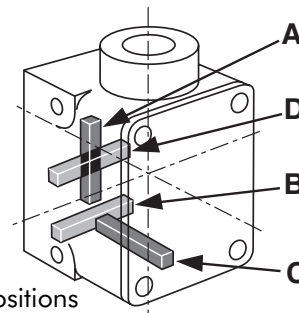

Reed positions

The electrical circuit in the hazardous area must be capable of withstanding an a.c. test voltage of 500 volts rms to earth or frame of the apparatus for one minute.

The installation must comply with the installation requirements as specified in BS5345: part 4:1997.

The power source must be certified by an EEC approved body to EExia or EExib, whichever is applicable with:

- U_i max out 30V
- I_i max out 250mA
- P_i max out 1.3W

The capacitance and inductance, or inductance to resistance (L/R) ratio of the hazardous area cables must not exceed the values of the power source in use.

Safe area apparatus is unspecified except that it must not be supplied from, nor contain under normal or abnormal conditions, a source of potential with respect to earth in excess of 250 volts rms or 250 volts d.c.

Special conditions of use - the cable must be terminated in an enclosure that provides a degree of protection of at least IP 20 for the connections.

dimensions

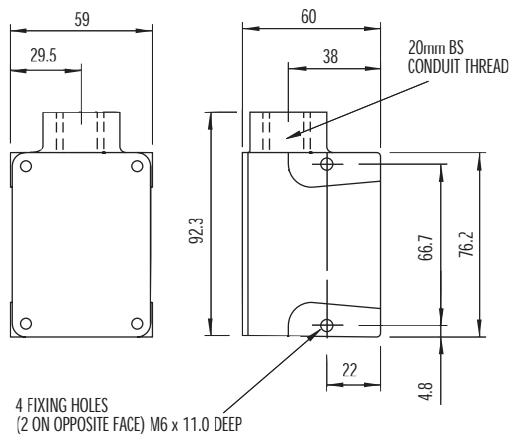

ordering details

Switch	Max. volts	Max. current	Power	Part No.	Aluminium	Mazak
A B C D = reed position MPS 1/A/1	600V peak	1.25A ac/ dc	20VAac 20Wdc	565030	565034	
MPS 1/B/1	600V peak	1.25A ac/ dc	20VAac 20Wdc	565031	565035	
MPS 1/C/1	600V peak	1.25A ac/ dc	20VAac 20Wdc	565032	565036	
MPS 1/D/1	600V peak	1.25A ac/ dc	20VAac 20Wdc	565033	565037	

These switches require a magnetic actuator. Refer to page 27.



technical specifications

Contact arrangement	N/O or C/O (change over)
Contact material	Rhodium
Case material	Stainless Steel (brass available for MPS3i)
Protection	IP 68 (water/oil/dust)
Operating temperature	-10°C to +70°C (MPS3i) -10°C to +60°C (ES2i, ES3i)
Fixings	2 x M3
Contact operating distance	See page 27
Mechanical life	500 x 10 ⁶ typical
Electrical life	Subject to switched load
Cable	2m flexible PVC.
Weight	0.2Kg
Conforms to standards	EN 50014, EN 50018, EN 60204-1

proximity switch & end sensors
MPS3i, ES2i, ES3i

- Magnetically actuated
 - See page 26 for actuators (supplied separately)
- Brass or Stainless Steel housing (MPS3i)
Nickel plated brass housing (ES2i, ES3i)
- Water, oil and dustproof to IP68

The electrical circuit in the hazardous area must be capable of withstanding an a.c. test voltage of 500 volts rms to earth or frame of the apparatus for one minute.

The installation must comply with the installation requirements as specified in EN 60079-14: 1997.

The power source must be certified by an EEC approved body to EExia or EExib, whichever is applicable with:

Ui max out 30V

Ii max out 250mA

Pi max out 1.3W

The capacitance and inductance, or inductance to resistance (L/R) ratio of the hazardous area cables must not exceed the values of the power source in use.

Safe area apparatus is unspecified except that it must not be supplied from, nor contain under normal or abnormal conditions, a source of potential with respect to earth in excess of 250 volts rms or 250 volts d.c.

Special conditions of use - the cable must be terminated in an enclosure that provides a degree of protection of at least IP 20 for the connections.

dimensions

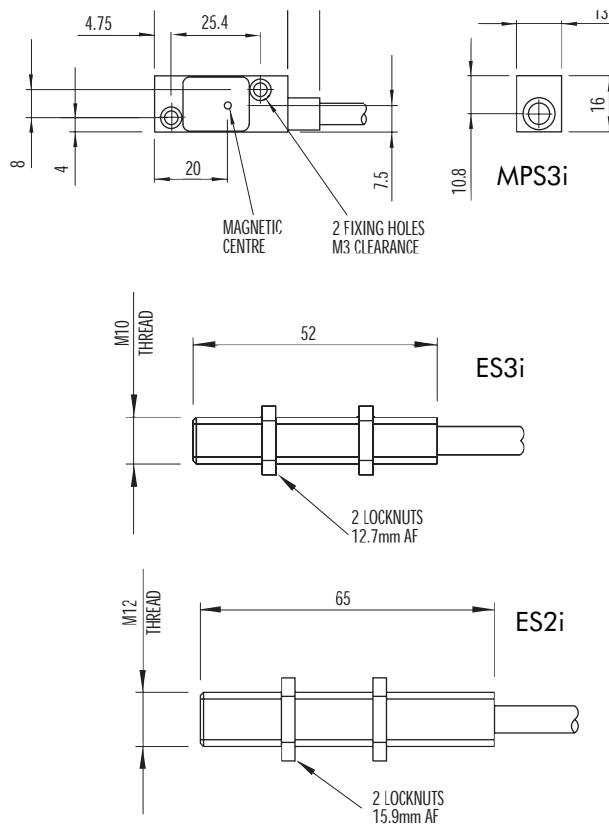

ordering details

Switch	Contacts	Max. volts	Max. current	Power	Part No.
MPS3i	C/O	175V dc	0.25A ac/dc	5VA/W	566365
MPS3i	N/O	250V ac/dc	1A ac/dc	15VA/W	566354
ES3i	N/O	250V ac/dc	1A ac/dc	15VA/W	566351
ES3i	C/O	175V dc	0.25A ac/dc	5VA/W	566356
ES3i	C/O	175V dc	0.25A ac/dc	5VA/W	566352
ES2i	C/O	175V dc	0.25A ac/dc	5VA/W	566350

These switches require a magnetic actuator. Refer to page 27



Industrial Switches & Sensors

Proximity switches

Proximity vane switches

Limit switches

End sensors

Security sensors

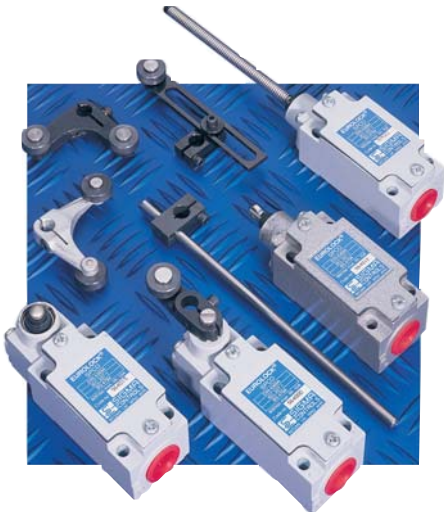

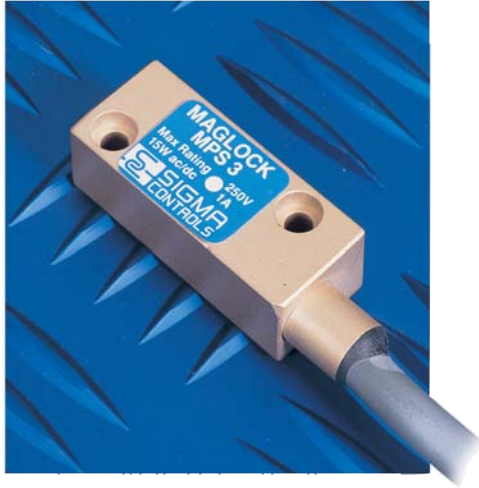

technical specifications

Contact arrangement	N/O single pole For resistive loads as supplied or inductive loads with an external surge suppressor.
Contact material	Rhodium
Case material	Brass (aluminium or stainless steel available to special order)
Protection	IP 68 (water/oil/dust)
Operating temperature	-10°C to +70°C
Fixings	2 x M3
Contact operating distance	See page 27
Mechanical life	500 x 10 ⁶ typical
Electrical life	Subject to switched load
Cable	2m flexible PVC.
Weight	0.2Kg
Conforms to standards	BS EN 60204-1

proximity switch MPS3

- Magnetically actuated
 - See page 27 for actuators (supplied separately)
- Brass or Stainless Steel housing
- Water, oil and dustproof to IP68
- For resistive loads

ordering details

Switch	Housing	Max. volts	Max. current	Power	Part No.
MPS 3	Brass	250V ac/dc	1A ac/dc	15VAac 15Wdc	565053
MPS 3	Stainless Steel	250V ac/dc	1A ac/dc	15VAac 15Wdc	565055

These switches require a magnetic actuator. Refer to page 27

dimensions

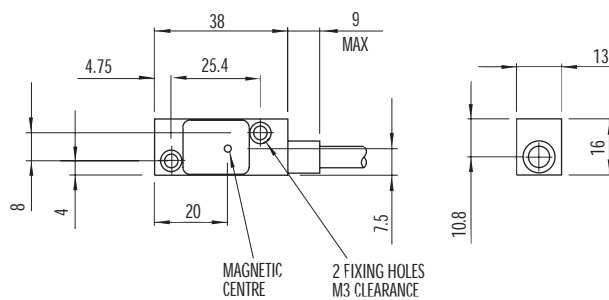



technical specifications

Contact arrangement	N/O single pole
Contact material	Gold Plated Silver
Initial contact resistance	0.015 ohm max.
Case material	Brass (aluminium, stainless steel or plastic available to special order)
Protection	IP 68 (water/oil/dust)
Operating temperature	-10°C to +70°C
Fixings	2 x M3
Contact operating distance	See page 27
Mechanical life	500 x 10 ⁶ typical
Electrical life	Subject to switched load
Cable	2m flexible PVC.
Weight	0.35Kg
Conforms to standards	BS EN 60204-1

**proximity switch
MPS 16**

- Magnetically actuated
 - See page 27 for actuators (supplied separately)
- Brass or Stainless Steel housing
- Water, oil and dustproof to IP68
- For inductive ac circuits

ordering details

Switch	Max electrical ratings	Housing	Part No.
MPS 16	0.75A resistive / 0.2A inductive at 110V dc ,	Brass	565071
	3A resistive / 1A inductive at 28V dc , 3A at 110Vac (max inrush 15A), 2A at 250Vac (max inrush 10A)	Stainless Steel	565073

These switches require a magnetic actuator. Refer to page 27

dimensions

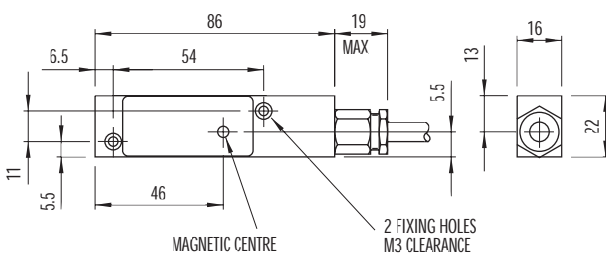



technical specifications

Contact arrangement	C/O single pole (changeover) For resistive loads as supplied or inductive loads with an external surge suppressor.
Contact material	Tungsten (Rhodium available for low current applications)
Case material	Brass (aluminium or stainless steel available to special order)
Protection	IP 68 (water/oil/dust)
Operating temperature	MPS 2, -10°C to +80°C MPS 12, -40°C to +150°C MPS 14, -10°C to +80°C
Fixings	2 x M3
Contact operating distance	See page 27
Mechanical life	500 x 10 ⁶ typical
Electrical life	Subject to switched load
Cable	MPS2 & MPS 14 - 2m flexible PVC. MPS12 - 3m MICC
Connections	MPS2 & MPS 14 - N/O - blue & black, N/C - brown & black. MPS 12 - cores unmarked
Weight	MPS 2 - 0.25Kg MPS 12 - 0.55Kg MPS 14 - 0.3Kg
Conforms to standards	BS EN 60204-1

proximity switch MPS 2, 12, 14

- Magnetically actuated
– See page 27 for actuators (supplied separately)
- Brass or Stainless Steel housing
- Water, oil and dustproof to IP68
- For resistive loads or inductive loads with an external surge suppressor.

dimensions

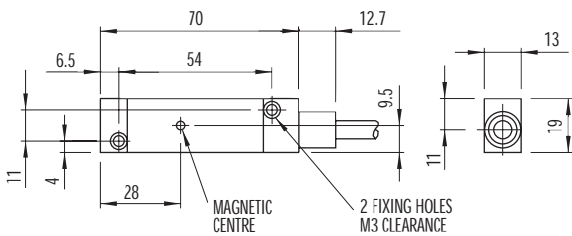

MPS 2

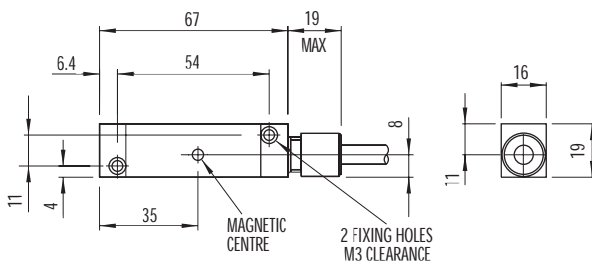

MPS 12, MPS 14

ordering details

Switch	Max. volts	Max. current	Power	Housing	Part No.
MPS 2	250V ac/dc	1.25A ac/dc	20W/VA max, 3W/VA min	Brass	565050
MPS 2	250V ac/dc	1.25A ac/dc	20W/VA max, 3W/VA min	Stainless Steel	565052
MPS 12	250V ac/dc	1.25A ac/dc	20W/VA max, 3W/VA min	Brass	565060
MPS 14	250V ac/dc	1.25A ac/dc	20W/VA max, 3W/VA min	Brass	565063
MPS 14	250V ac/dc	1.25A ac/dc	20W/VA max, 3W/VA min	Stainless Steel	565065

These switches require a magnetic actuator. Refer to page 27



end sensors ES1, ES2

- End sensing
- Magnetically actuated
 - See page 27 for actuators (supplied separately)
- Nickel plated brass or stainless steel housing
- Water, oil and dustproof to IP68

dimensions

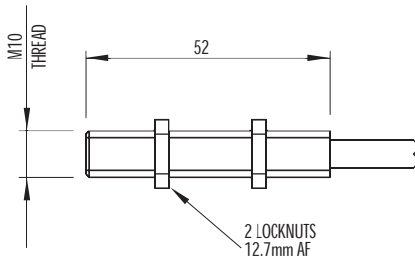

ES 1

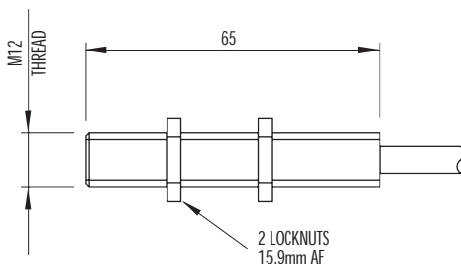

ES 2

technical specifications

Contact arrangement	ES 1 - N/O single pole ES 2 - C/O single pole (changeover)
Contact material	ES 1 - Rhodium ES 2 - Tungsten (Rhodium available to special order)
Case material	Nickel plated brass or stainless steel
Protection	IP 68 (water/oil/dust)
Operating temperature	-18°C to +80°C (versions up to +170°C available to special order)
Fixings	2 locknuts provided
Contact operating distance	See page 27
Mechanical life	500 x 10 ⁶ typical
Electrical life	Subject to switched load
Cable	2m high temperature flexible PVC.
Connections	ES 1 - N/O - blue & black, N/C - brown & black.
Weight	0.2Kg
Conforms to standards	BS EN 60204-1

ordering details

Switch	Max. volts	Max. current	Power	Housing	Part No.
ES 1	250Vdc 300Vac	1A ac/dc	15W/VA	Brass	565088
ES 1	250Vdc 300Vac	1A ac/dc	15W/VA	Stainless Steel	565095
ES 2	250V ac/dc	3A ac/dc	20W/VA	Brass	565089
ES 2	250V ac/dc	3A ac/dc	20W/VA	Stainless Steel	565096

These switches require a magnetic actuator. Refer to page 27



technical specifications

Contact arrangement	C/O single pole (change over)
Contact material	Tungsten (Rhodium available)
Case material	Aluminium or Mazak
Protection	IP 65 (water/oil/dust)
Operating temperature	-10°C to +50°C
Fixings	4 x M6
Contact operating distance	See page 27
Mechanical life	500 x 10 ⁶ typical
Electrical life	Subject to switched load
Cable entry	20mm conduit entry.
Weight	Aluminium 0.6Kg, Mazak1Kg
Conforms to standards	BS EN 60204-1

proximity switches

MPS 1/1, 1/5

- Magnetically actuated
 - See page 27 for actuators (supplied separately)
- Aluminium or Mazak housings
- Water, oil and dustproof to IP65
- MPS 1/1 For resistive loads
- MPS 1/5 For resistive or inductive loads (incorporates a surge suppressor)
- Choice of reed positions

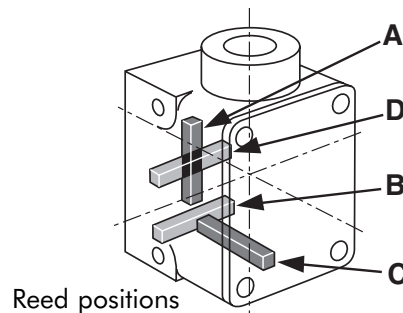

Reed positions

dimensions

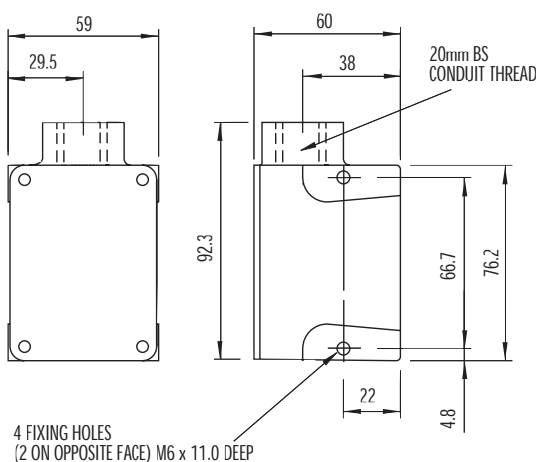

ordering details

Switch type A B C D = reed position	Max volts	Max current	Power	Part No.	
				Aluminium	Mazak
MPS 1/A/1	250Vac(rms)/dc	1.25Aac/dc	20VA ac, 20W dc, 3VA/W min. (1)	565000	565012
MPS 1/B/1	250Vac(rms)/dc	1.25Aac/dc	20VA ac, 20W dc, 3VA/W min. (1)	565001	565013
MPS 1/C/1	250Vac(rms)/dc	1.25Aac/dc	20VA ac, 20W dc, 3VA/W min. (1)	565002	565014
MPS 1/D/1	250Vac(rms)/dc	1.25Aac/dc	20VA ac, 20W dc, 3VA/W min. (1)	565003	565015
MPS 1/A/5	250Vac(rms)/dc	1.25Aac/dc	20VA ac, 20W dc, 3VA/W min. (2)	565008	565020
MPS 1/B/5	250Vac(rms)/dc	1.25Aac/dc	20VA ac, 20W dc, 3VA/W min. (2)	565009	565021
MPS 1/C/5	250Vac(rms)/dc	1.25Aac/dc	20VA ac, 20W dc, 3VA/W min. (2)	565010	565022
MPS 1/D/5	250Vac(rms)/dc	1.25Aac/dc	20VA ac, 20W dc, 3VA/W min. (2)	565011	565023

(1) = Resistive only

(2) = Resistive or inductive

These switches require a magnetic actuator. Refer to page 27

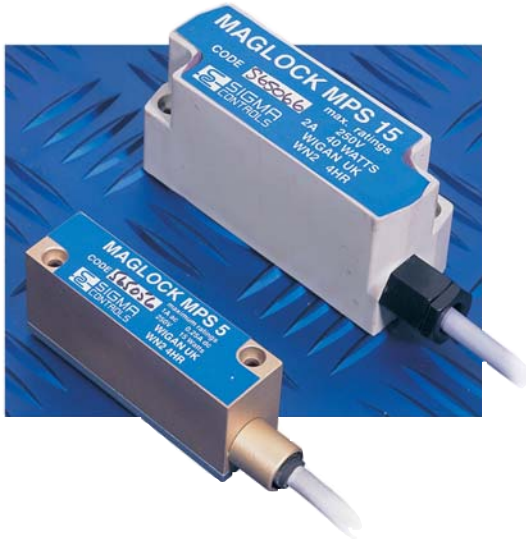

technical specifications

Contact arrangement	N/O single pole
Contact material	MPS 5 - Rhodium MPS 15 - Tungsten
Case material	MPS 5 - Brass MPS 15 - Glass reinforced Nylon
Protection	IP 68 (water/oil/dust)
Operating temperature	-10°C to +50°C
Fixings	MPS 5 - 2 x M3 MPS 15 - 2 x M4
Contact operating distance	See page 27
Mechanical life	500 x 10 ⁶ typical
Electrical life	Subject to switched load
Cable	2m flexible PVC.
Weight	0.5Kg
Conforms to standards	BS EN 60204-1

**proximity switches
MPS 5, 15**

- Ferro-actuated – Senses ferrous material
e.g. mild steel
- MPS 5 Brass housing
- MPS 15 Glass filled Nylon housing
- Water, oil and dustproof to IP68

ordering details

Switch	Max. volts	Max. current	Power	Part No.
MPS 5	250V ac/dc	1A ac/ 0.25A dc	15VA ac, 15W dc	565056
MPS 15	250V ac/dc	2A ac/dc	40VA ac, 40W dc, 3W/VA min	565066

This switch is actuated by ferrous metal such as mild steel.

dimensions

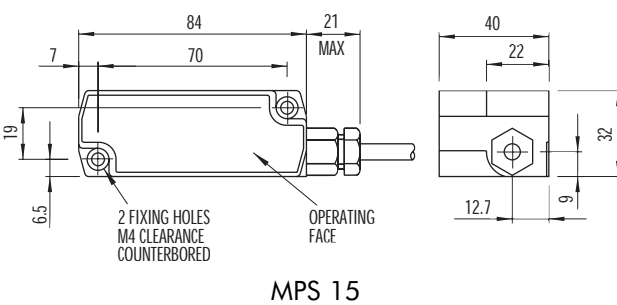
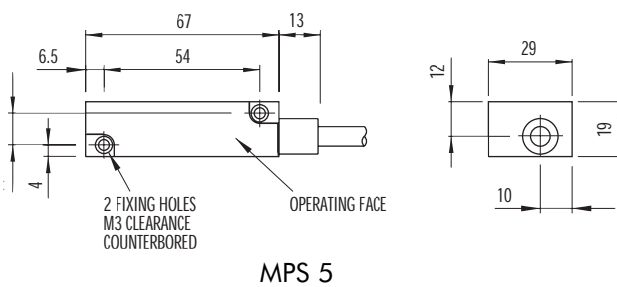



technical specifications

Contact arrangement	MPS V1 - C/O single pole (surge suppression circuit) MPS V3 - N/O or N/C single pole (triac network & surge suppression circuit) MPS V4 - C/O single pole (resistive loads only)
Contact material	Tungsten (Rhodium available)
Case material	Glass filled Nylon
Protection	IP 68 (water/oil/dust)
Operating temperature	-10°C to +50°C
Fixings	2 x M5
Mechanical life	500 x 10 ⁶ typical
Electrical life	Subject to switched load
Cable	2m flexible PVC Cores unmarked
Connections	MPS V1 & 4 - N/O blue & black N/C - brown & black MPS V3:

proximity switches MPS V1, V3, V4

- Ferro-actuated vane switch
- Senses ferrous material e.g. mild steel
- MPS V1 for inductive loads
- MPS V3 for inductive or resistive a.c. loads
- MPS V4 for resistive loads only
- Glass filled Nylon housing
- Water, oil and dustproof to IP68



N/O - link red & black (B)
N/C - link blue & black (A)
Note: Any number of MPS V3s may be connected in parallel but a maximum of three only may be connected in series. For series connection, connect the individual circuits as required but connect the black & white leads in series.

Weight MPS V1 & 4 - 0.75Kg

MPS V3 - 1Kg

Conforms to standards BS EN 60204-1

dimensions

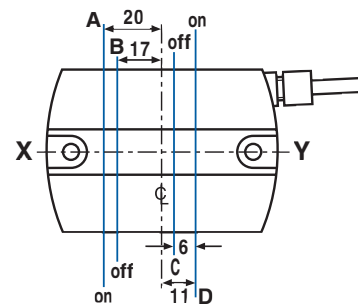
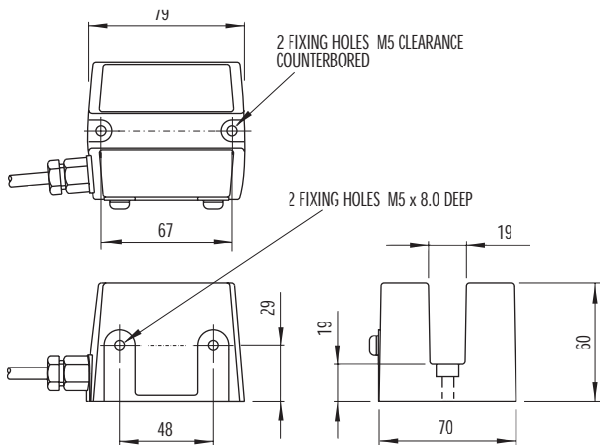

Vane movement	X to Y	Y to X	X to Y & return	Y to X & return
Switch operates when leading edge of vane is at point	D	A	D	A
Switch will reset when trailing edge of vane is at point	C	B		
Switch will reset when leading edge of vane is at point			C	B

NOTE: The maximum variation in the above operating positions due to having the vane ±9.5mm from the nominal position of 9.5mm from the base is 1.5mm.

ordering details

Switch	Max. volts	Max. current	Power	Part No.
MPS V1	250V ac/dc	1.25A ac/dc	20Wdc, 20VAac, 3W/VA min	565090
MPS V3	65V TO 265V ac only	5A cont. - 10A for 5 secs. 30A for 10 msecs.	720VA ac (min load 150mA)	565092
MPS V4	250V ac/dc	1.25A ac/dc	20Wdc, 20VAac, 3W/VA min	565093



technical specifications

Contact arrangement	See ordering details
Contact material	Silver (gold plated silver available)
Case material	Aluminium or Mazak
Protection	IP66
Operating temperature	-20°C to +75°C (high temperature version to +150°C available)
Mechanical life	20 x 10 ⁶ typical
Electrical life	Subject to switched load
Weight	0.8Kg
Conforms to standards	BS EN 60204-1
Electrical ratings	
Surge capacity	20A ac
Continuous capacity	10A ac/dc
Rupturing capacity - inductive	10A ac / 2A dc
Rupturing capacity - non-inductive	10A ac / 1A dc

limit switches

snaplock 600

- The definitive snap acting heavy duty limit switch
- large range of levers (supplied separately) adjustable in 7.5° increments over 165°
- Die cast Aluminium or Mazak housings
- Spring movable for clockwise (as supplied) or counter clockwise operation. Removable for maintained contact either side

ordering details

600 Switch type	Contact arrangement	Part No. Aluminium	Part No. Mazak
Standard switch (supplied with 2 styles of backplate)	1N/O, 1N/C	560010	560510
Neutral position switch (supplied with 2 styles of backplate)	2N/O	560118	560618
Tandem switch	2N/O, 2N/C	560337	560837
Tandem neutral position switch	4N/O	560373	560873

See Dimension drawings below for lever part numbers.

dimensions

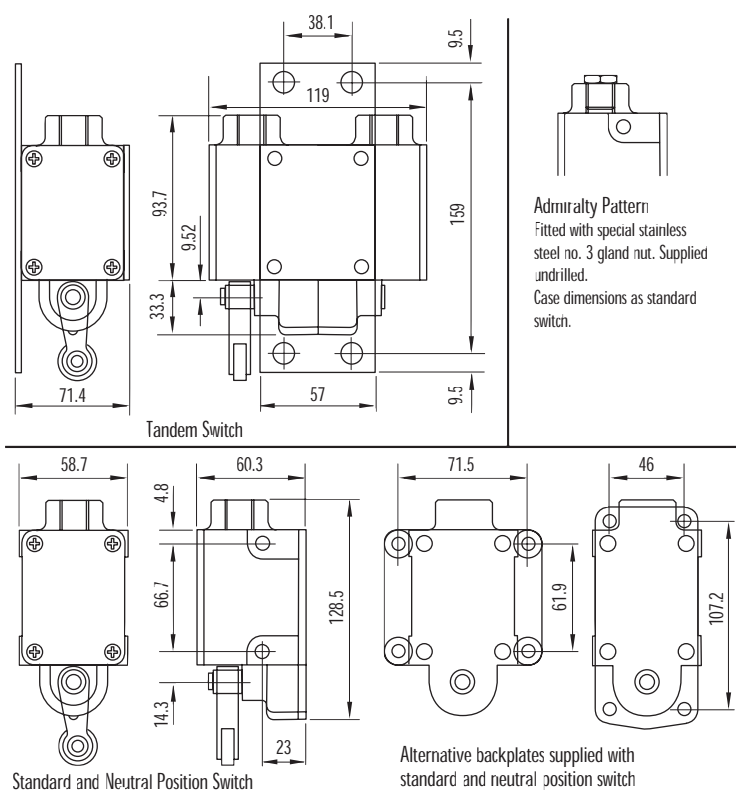

LEVERS

Switches and levers are supplied separately. A small selection of levers is shown here. Please contact us for details of other types.

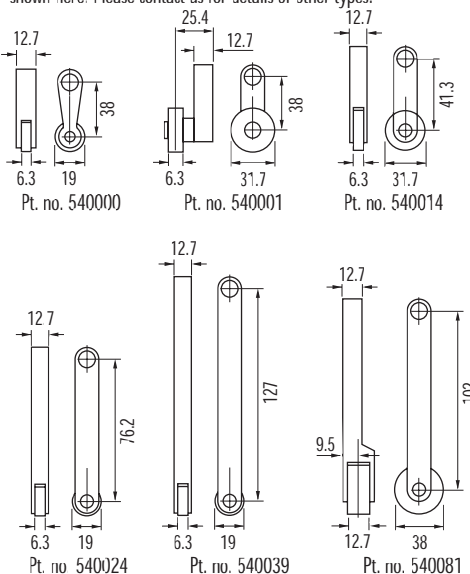

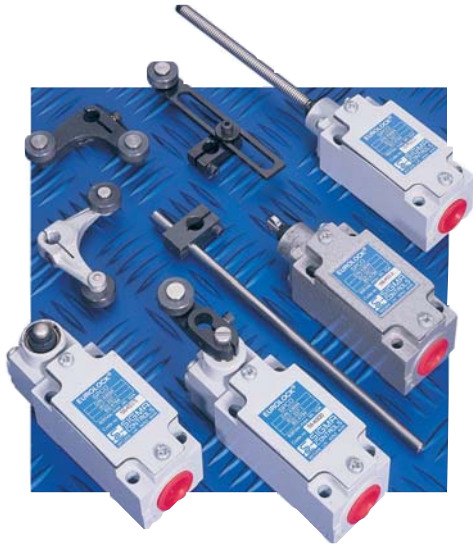

technical specifications

Contact arrangement	C/O single or double pole (change over) snap acting
Contact material	Nickel silver
Rated voltage	600V ac / 240V dc
Rated thermal current	10A
Case material	Mazak
Protection	IP65
Operating temperature	-20°C to +70°C
Mechanical life	20 x 10 ⁶ typical
Electrical life	Subject to switched load
Cable entry	20mm conduit entry
Weight	0.8Kg
Conforms to standards	DIN 43694, EN 50041 BS EN 60204-1

limit switches

eurolock

- Conforms to DIN 43694, EN 50041
- Snap acting contacts
- Roller, plunger or lever actuation
- Diecast Mazak housing

dimensions & ordering details

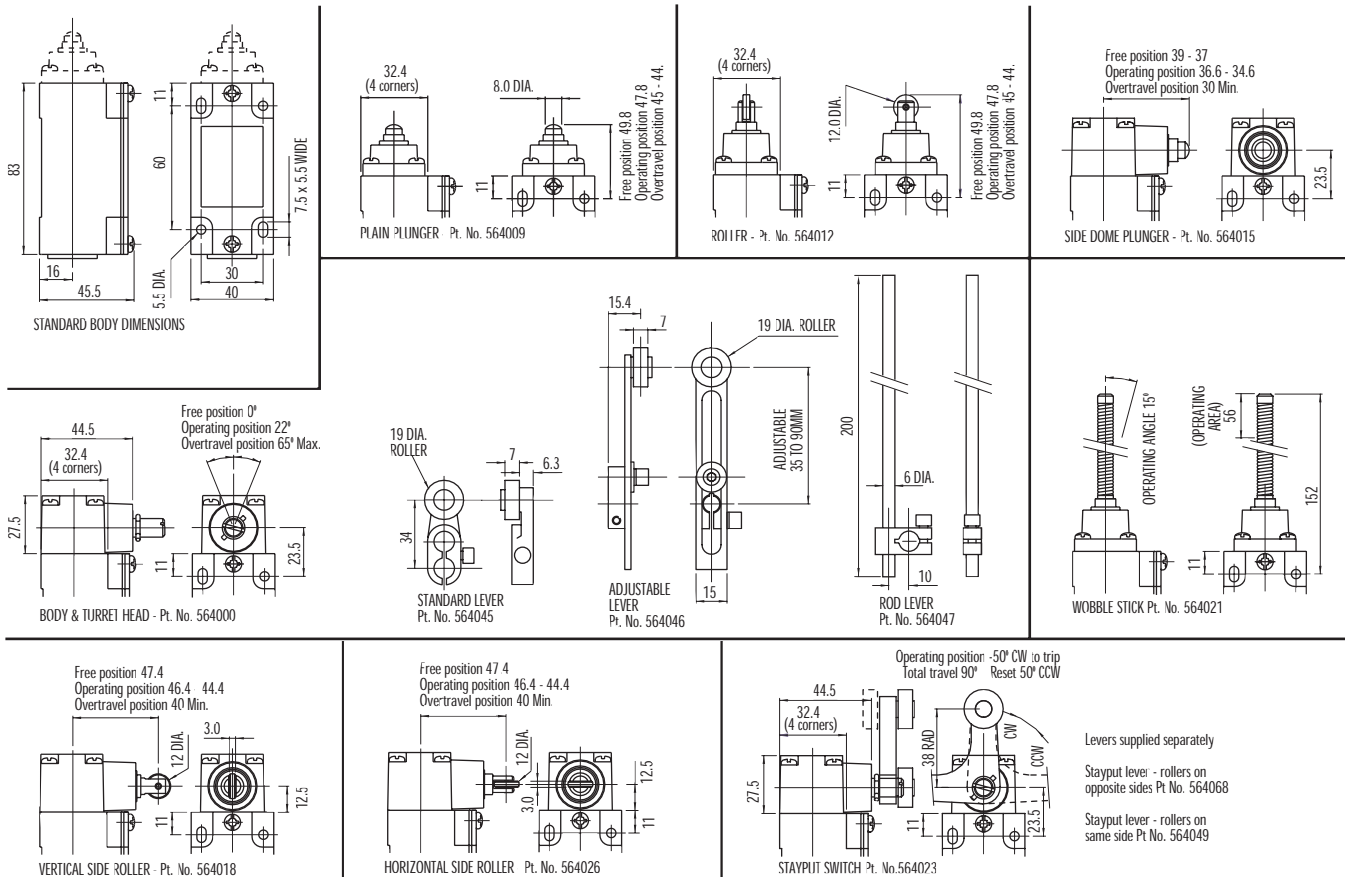

Lever supplied separately
 Stayput lever - rollers on opposite sides Pt No. 564068
 Stayput lever - rollers on same side Pt No. 564049



technical specifications

Contact arrangement	C/O single pole (changeover)
Contact material	Silver (gold plated available)
Max. volts	250V ac / 30V dc
Max. amps	5A at 250V ac (inductive or resistive). 5A at 30V dc (resistive). 3A at 30V dc (inductive)
Case material	Die-cast aluminium
Protection	IP66 - gaitered IP65 - non-gaitered
Operating temperature	-40°C to +70°C
Mechanical life	2 x 10 ⁶ typical
Electrical life	5 x 10 ⁴ at 5A 250V ac resistive
Cable	1m flexible PVC. 4 core
Connections	N/O - black & blue N/C - brown & blue Earth - green/yellow
Weight	0.2Kg
Conforms to standards	BS 775 part 1, BS EN 60204-1

limit switches microlock series 631

- Snap acting contacts
- Sealed for life aluminium bodies
- IP 65 & IP66 versions

dimensions & ordering details

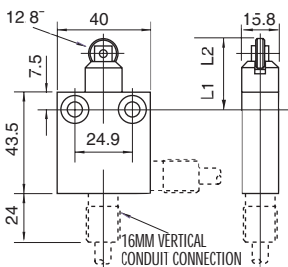

IN-LINE ROLLER PLUNGER	
Cable entry type	Part no.
Vertical plain cable entry	563100
Vertical conduit connection	563101
Side conduit connection	563108

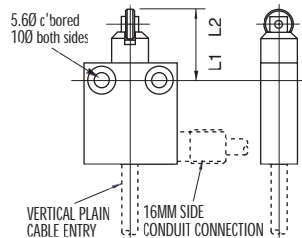

90° ROLLER PLUNGER	
Cable entry type	Part no.
Vertical plain cable entry	563102
Vertical conduit connection	563103
Side conduit connection	563109

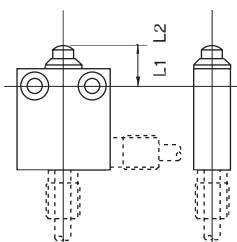

PLAIN END PLUNGER	
Cable entry type	Part no.
Vertical plain cable entry	563104
Vertical conduit connection	563105
Side conduit connection	563110

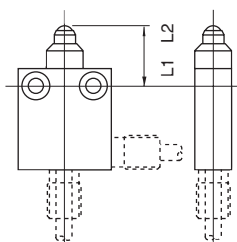

BALL END PLUNGER	
Cable entry type	Part no.
Vertical plain cable entry	563106
Vertical conduit connection	563107
Side conduit connection	563111

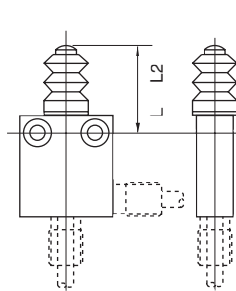

PLAIN END PLUNGER WITH GAITER	
Cable entry type	Part no.
Vertical plain cable entry	563112
Vertical conduit connection	563114
Side conduit connection	563116

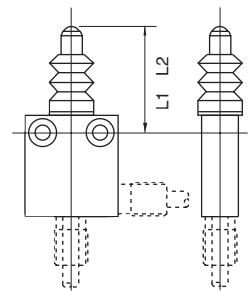

BALL END PLUNGER WITH GAITER	
Cable entry type	Part no.
Vertical plain cable entry	563113
Vertical conduit connection	563115
Side conduit connection	563117

operating details

	Switches					
	563100	563102	563104	563106	563112	563113
	563101	563103	563105	563107	563114	563115
	563108	563109	563110	563111	563116	563117
Operating force (N)	9.5	9.5	9.5	9.5	15.0	15.0
Release force – min (N)	4.5	4.5	4.5	4.5	7.0	7.0
Pre-travel – max (mm)	2.0	2.0	2.0	2.0	2.0	2.0
Overtravel – max (mm)	3.0	3.0	3.0	3.0	3.0	3.0
Differential – max (mm)	0.1	0.1	0.1	0.1	0.1	0.1
Operating point L1 (mm)	28 ± 1.0	28 ± 1.0	16 ± 1.0	24.4 ± 1.0	28.7 ± 1.0	37.1 ± 1.0
Free position L2 – max (mm)	30.25	30.25	17.5	25.9	30.25	38.65



technical specifications

Securilock S2 - Electrical ratings	
Max volts (resistive)	140V ac / 200V dc
Max amps (resistive)	250mA
Max power (resistive)	3W

Surge suppression is required for inductive loads. Details available on request

Internal circuit configuration

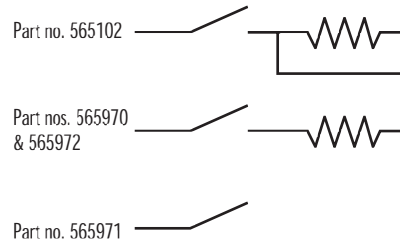

security sensor securilock series 2

- Suitable for high security areas
- Magnetically operated
- Balanced reed switch principle
- Tamper proof - Actuator removal or external magnetic influence causes change of state
- Switch incorporates a resistor which can be wired in or out of circuit

The Securilock S1 version is also available. Details available on request.

ordering details

Description	Part No.
Securilock S2 switch	565102
Securilock S2 switch 470 R	565970
Securilock S2 switch 240 R	565972
Securilock S2 switch 0 R	565971
Securilock A8 magnetic actuator	565103
Securilock A3 magnetic actuator (for surface mounting)	545006

dimensions

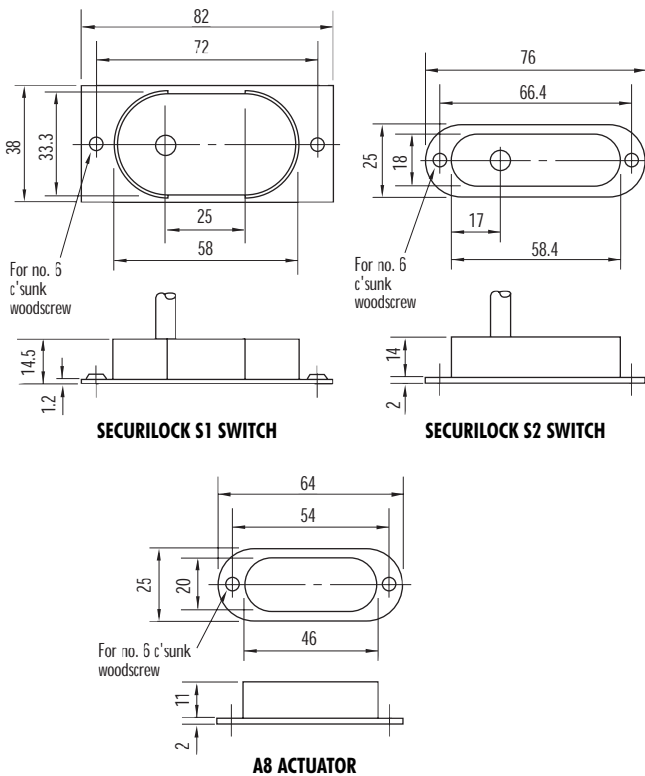

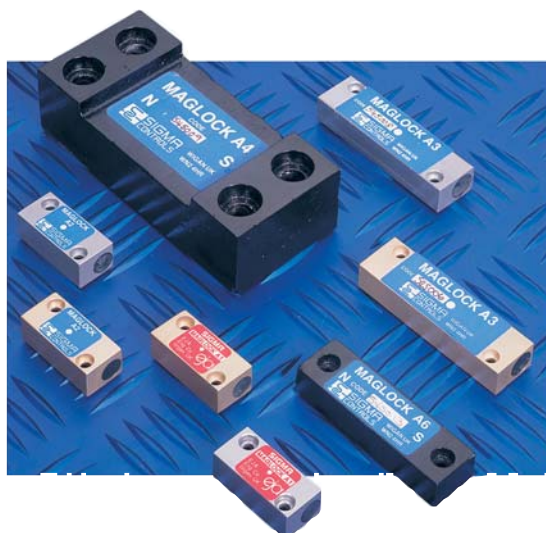

operating distance & differential

The 'operating distance' is the maximum distance at which the switch just operates, with the operating faces parallel and in line, the magnetic centres opposite each other and the actuator moving towards the switch. When the actuator is withdrawn the switch will reset itself at a distance greater than this, the difference between the two distances is termed as the differential.

Operating distances and differentials for all Maglock magnetic proximity switches are quoted below. They only apply however when both the switch and the actuator are mounted away from any ferro-magnetic materials.

Mounting on or close to such materials will reduce these distances, but if there is no alternative then mounting the switch and the actuator on spacers, also described in this section, will help reduce the effect.

magnetic actuators & spacers

spacers

Spacers are available to provide magnetic isolation in cases where the mounting of switches or magnetic actuators directly on ferro-magnetic materials cannot be avoided. They are supplied in kits which suit all actuators and consist of two spacers and the appropriate fasteners.

Spacer material	Thickness mm	Part no
Brass	12	545056
Stainless steel	12	545057

operating distance for end sensing switches

The operating information given applies for end-sensing models only if the switches are mounted away from ferro-magnetic materials by the minimum X and Y distances shown in the diagram. Reducing these clearances will reduce the operating distance and affect the differential.

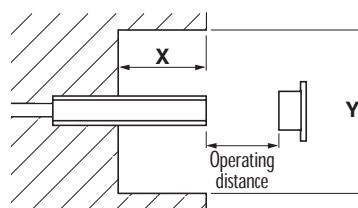

actuators for end sensing switches

	Actuator type	Part number	Suitable for switch type	Clearance (mm) (see diagram)		Operating distance mm	Differential	
				X	Y		Max mm	Typical mm
	E1	545038	ES 1	25	60	10	6	3
	E2	545039	ES 1	25	70	13	5	3
			ES 2	32	80	10	6	3
			ES 24T	33	80	8	6	3
			ES 34T	33	80	8	6	3
	E3	545040	ES 1	25	80	30	4	3
			ES 2	32	110	25	6	4
			ES 24T	33	110	23	6	4
			ES 34T	33	110	23	6	4
	E10	545098	ES 1	25	70	16	6	4
			ES 2	32	80	10	6	3
			ES 24T	33	80	8	4	2
			ES 34T	33	80	8	4	2

actuators for side sensing switches

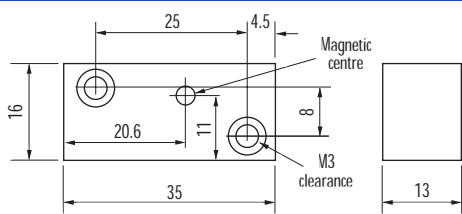
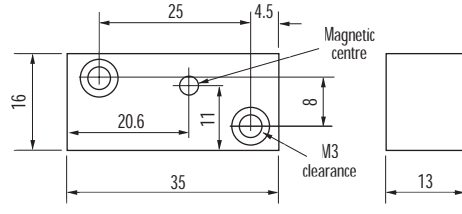
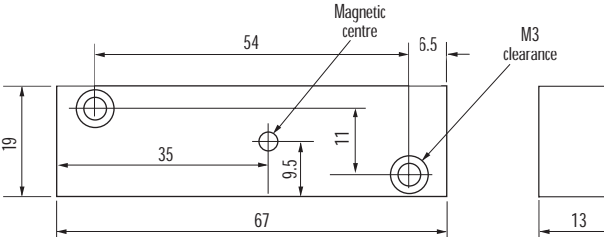
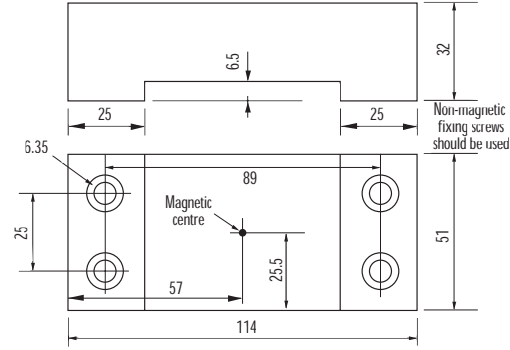
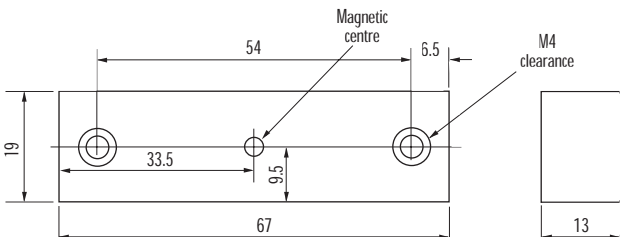
	Actuator type	Part number	Suitable for switch type	Operating distance mm	Differential	
					Max mm	Typical mm
 <p>Non-magnetic fixing screws should be used.</p>	A1	545000 Brass 545002 Stainless steel	MPS3	10	10	7
 <p>Non-magnetic fixing screws should be used.</p>	A2	545003 Brass 545005 Stainless steel	MPS1 MPS2 MPS3 MPS12 MPS14 MPS21 MPS24D MPS34D MPS44	10 10 16 6 6 10 3 3 6	16 16 13 16 16 16 16 16 16	11 11 10 11 11 11 11 11 11
 <p>Non-magnetic fixing screws should be used.</p>	A3	545006 Brass 545008 Stainless steel	MPS1 MPS2 MPS3 MPS12 MPS14 MPS21 MPS24D MPS34D MPS44	22 22 25 19 19 22 16 16 19	25 25 25 25 25 25 25 25 25	17 17 17 17 17 17 17 17 17
 <p>Non-magnetic fixing screws should be used.</p>	A4	545009	MPS1 MPS2 MPS3 MPS12 MPS14 MPS16 MPS21 MPS24D MPS26D MPS34D MPS36D MPS44	95 95 108 86 86 29 96 83 27 83 27 86	63 63 51 63 63 42 63 63 42 63 42 63	50 50 38 50 50 32 50 50 32 50 32 50
 <p>Non-magnetic fixing screws should be used.</p>	A6	545013	MPS1 MPS2 MPS3 MPS12 MPS14 MPS16 MPS21 MPS24D MPS26D MPS34D MPS36D MPS44	48 48 59 47 47 17 48 44 15 44 15 47	42 42 29 42 42 29 42 42 29 42 29 42	25 25 17 25 25 17 25 25 17 25 17 25

EJA Limited
Hindley Green Industrial Estate
Wigan, Lancashire. WN2 4HR. ENGLAND

Tel: +44 1942 255166
Fax: +44 1942 523259
www.ab.com/safety
www.ejaltd.co.uk

AUDIN

Composants & systèmes d'automatisme
8, avenue de la malle - 51370 St Brice Courcelles
Tel. +33(0)326042021 • Fax +33(0)326042820
http://www.audin.fr • e-mail info@audin.fr

www.rockwellautomation.com

Corporate Headquarters

Rockwell Automation, 777 East Wisconsin Avenue, Suite 1400, Milwaukee, WI, 53202-5302 USA. Tel: (1) 414.212.5200, Fax: (1) 414.212.5201

Headquarters for Allen-Bradley Products, Rockwell Software Products and Global Manufacturing Solutions

Americas: Rockwell Automation, 1201 South Second Street, Milwaukee, WI 53204-2496 USA. Tel: (1) 414.382.2000, Fax: (1) 414.382.4444
Europe: Rockwell Automation SA/NV, Vorstlaan/Boulevard du Souverain 36-BP 3A/B, 1170 Brussels, Belgium. Tel: (32) 2 663 0600, Fax: (32) 2 663 0640
Asia Pacific: Rockwell Automation, 27/F Citicorp Centre, 18 Whitfield Road, Causeway Bay, Hong Kong. Tel: (852) 2887 4788, Fax: (852) 2508 1846

Headquarters for Dodge and Reliance Electric Products

Americas: Rockwell Automation, 6040 Ponders Court, Greenville, SC 29615-4617 USA. Tel: (1) 864.297.4800, Fax: (1) 864.281.2433
Europe: Rockwell Automation, Brühlstraße 22, D-74834 Elztal-Dallau, Germany. Tel: (49) 6261 9410, Fax: (49) 6261 1774
Asia Pacific: Rockwell Automation, 55 Newton Road, #11-01/02 Revenue House, Singapore 307987. Tel: (65) 351 6723, Fax: (65) 355 1733