



**Rockwell
Automation**



NX70 Series Programmable Controllers NX70-CPU70p1 and NX70-CPUp2 User Manual

Important User Information

Solid state equipment has operational characteristics differing from those of electromechanical equipment. Because of these differences, and also because of the wide variety of uses for solid state equipment, all persons responsible for applying this equipment must satisfy themselves that each intended application of this equipment is acceptable.

In no event will Rockwell Samsung Automation be responsible or liable for indirect or consequential damages resulting from the use or application of this equipment.

The examples and diagrams in this manual are included solely for illustrative purposes. Because of the many variables and requirements associated with any particular installation, Rockwell Samsung Automation cannot assume responsibility or liability for actual use based on the examples and diagrams.

No patent liability is assumed by Rockwell Samsung Automation. with respect to use of information, circuits, equipment, or software described in this manual.

Reproduction of the contents of this manual, in whole or in part, without written permission of Rockwell Samsung Automation. is prohibited.

Throughout this manual we use notes to make you aware of safety considerations.

WARNING

Identifies information about practices or circumstances which may lead to serious personal injury or death, property damage, or economic loss.

IMPORTANT

Identifies information that is critical for successful application and understanding of the product.

ATTENTION

Identifies information about practices or circumstances that can lead to minor personal injury, property damage, economic loss, or product malfunction. However, depending on circumstances, failure to follow the directions accompanying this symbol may also lead to serious consequences.

Contents

1. System Configuration	7
NX70 Series PLC Features and System Configuration	7
Module Types and Combinations.....	10
Programming Tools	14
2. Hardware Features and Specifications.....	15
Overall Specifications	15
Backplane.....	17
Processor Module	19
Power Supply Module	24
I/O Modules.....	26
3. Addressing Overview	37
Double Word Addressing	39
Absolute Addressing.....	40
I/O Addressing	41
Special Registers	43
Timer/Counter Area.....	50
Processor Operation Mode.....	54
Processor Processing Procedure	55
4. Installations.....	57
Power Supply Module Wiring	59
Input and Output Wiring.....	61
Terminal Block Type Module Wiring	68
Connector Type Module Wiring	69
Safety Measures.....	73
NX70 Processor Module Communications Specifications	74
EEPROM Backup (for NX70-CPU70p1, NX70-CPU70p2)	75
5. Test Run and Troubleshooting	77
Test Run Precautions	77
Test Run Procedure.....	78
Test Run Flow Charts	79
Inspection and Maintenance	85

6. Programming Instructions.....	89
Basic Sequence Instructions	89
Timer, Counter and Shift Register Instructions	90
Comparison Instructions	91
Substitution, Increment and Decrement Instructions	91
Arithmetic Instructions	92
Logical Instructions	93
Rotation Instructions.....	93
Word Conversion Instructions	94
Bit Conversion Instructions	95
Move Instructions.....	96
Program Control Instructions.....	97
System Control Instructions.....	98
Communications Control Instructions.....	99
7. Catalog Numbers and Dimensions	101
NX70 Product Catalog Numbers.....	101
NX70 Product Dimensions	106
Decimal, Bin, Hex, BCD, Gray Code Cross-reference Table.....	109
ASCII Code Table.....	110
Appendix - Communication Protocols for NX70	111
Communication Protocols for NX70 (NX70-CPU70p1 and NX70-CPU70p2)	111
Communication Protocols.....	112
Structure of Communication Frames	117
Communication Program Examples.....	122

Safety Considerations

Please read this manual and the related documentation thoroughly and familiarize yourself with the directions before installing, operating or performing inspection and preventive maintenance. Make sure to follow the directions correctly to ensure normal operation of the product and your safety.

WARNING



- If this product is used in a situation that may cause personal injury and/or significant product damage, implement safety measures such as use of fault-safe equipment.
 - Do not use this product under the conditions exposed to explosive gases. It may cause an explosion.
-

ATTENTION



- Make sure to use an external device when configuring the protective circuit breakers for emergencies or interlock circuits.
 - Fasten the terminal screws tightly to ensure that the cable connection is secure. Incorrect cable connection may cause overheating and product malfunction.
 - Operate and keep the product under the allowed conditions directed in product specifications. Otherwise it may cause overheating and product malfunction.
 - Do not disassemble or remodel the product. Otherwise it may cause an electric shock or malfunction.
 - Do not touch the terminals when the power is on. Otherwise it may cause an electric shock.
-

Installation Environment

ATTENTION

Do not install your PLC system if any of the following conditions are present.:

- Ambient temperature outside the range of 0 to 55 °C (32 to 131 °F).
 - Direct sunlight.
 - Humidity outside the range of 30% to 85% (non-condensing)
 - Chemicals that may affect electronic parts.
 - Excessive or conductive dust, or salinity.
 - High voltage, strong magnetic fields, or strong electromagnetic influences.
 - Direct impact and excessive vibration.
-

ATTENTION

Electrostatic Discharges

Under dry condition, excessive electrostatic discharges may occur. Make sure to remove electrostatic discharges by touching a grounded metal piece before touching your controller system modules.

ATTENTION

Cleaning

Never use chemicals such as thinner because they melt, deform or discolor PCB boards.

ATTENTION

Precautions for use of power

- Run your PLC system only after the I/O devices and motor devices have started. (For example, first power on in the PROG mode, then change the operation mode to RUN.)
 - Make sure to power off I/O devices after ensuring PLC operation is stopped.
 - If you power on/off I/O devices when the PLC system is in operation, the system may malfunction because input signal noises may be recognized as normal inputs.
-

ATTENTION

Before powering on

Make sure to follow these directions before powering on your PLC system.

- When installing the system, ensure that there are no metal chips or conductive fragments that stick to wiring cables.
 - Ensure that power supply and I/O wirings and power supply voltage are all correct.
 - Securely fasten installation and terminal screws.
 - Set the operation mode switch to PROG mode.
-

System Configuration

NX70 Series PLC Features and System Configuration

System configuration

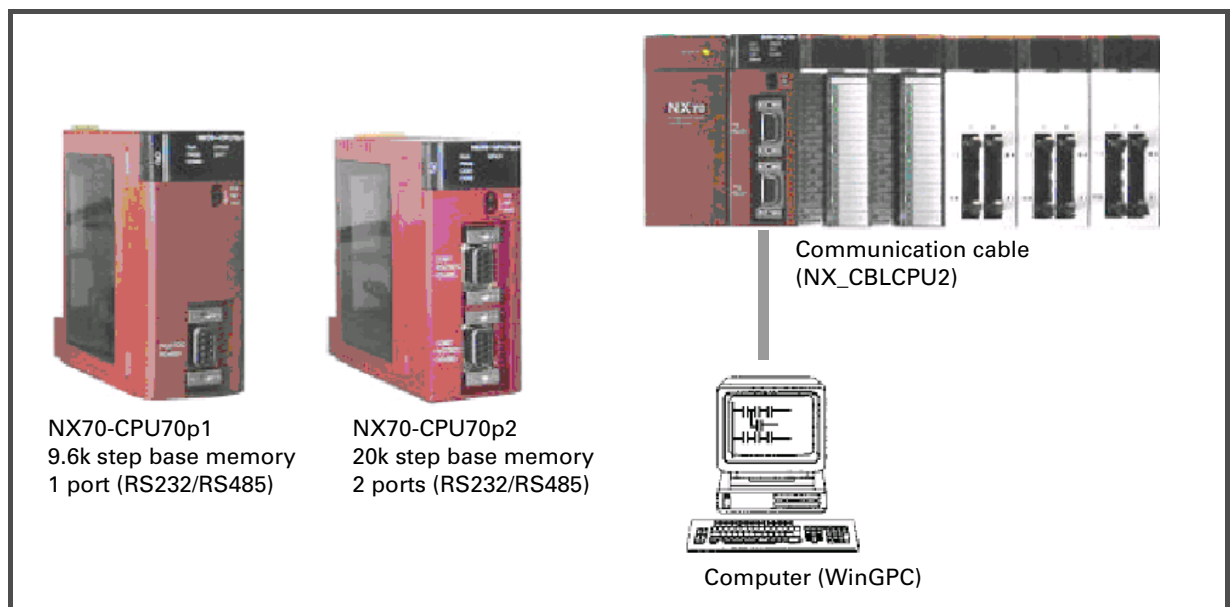

Features

- **High-speed processing**
With the high-speed ASIC, the NX70 processes basic instructions at a speed of 0.2 μ s per step.
- **Runtime Editing**
The NX70 processor module allows you to modify instructions while operating.
- **Built-In Real Time Clock (RTC)**
Built-in real time clock supports programming by time and date. (Supported only for the NX70-CPU70p2 module.)

- **High-capacity programming and memory backup**
The NX70 module allows you to program up to 20K words for NX70_CPU70p2, and 9.6k words for NX70_CPU70p1. Built-in flash EEPROM allows you to save programs separately.
- **Self-diagnostics**
Self-diagnostics allows you to minimize system errors and maximize diagnostic efficiency.
- **Maximum 384 I/O points**
With 12-slot processor module, you can use up to 384 I/O points (with terminal block type, 192 points).
- **Supports various I/O and specialty modules**
The NX70 processor module supports 24V dc input (16/32 points), 110V ac input, 220V ac input, relay output, transistor output (16/32 points), SSR output, A/D (4 channels), D/A (4 channels), RTD (4 channels), TC (4 channels), high-speed counter, and SCU.
- **WinGPC as programming tool**
WinGPC, designed for processor control, lets you create, modify, force I/O, download, and upload the program. It is a powerful, easy-to-use programming tool.
- **Various I/O base options (up to 12 slots)**
NX series PLC allows you to choose a backplane from 2, 3, 5, 6, 8, 10, or 12 slots for maximum system configuration flexibility.
- **Built-in RS232C/RS485, 2 ports (NX70-CPU70p2 module)**
With two built-in communication ports, the CPU70p2 module allows you to connect directly to computers or touch panels and exchange a high volume of data at high speed. The COM2 port supports a simple user-defined communication, and allows you to connect to barcode readers, inverters, or servo motors. (Binary communication is available.)

2-Slot Type



(NX70-BASE02)
32 Points: 16-point I/O
64 Points: 32-point I/O

3-Slot Type



(NX70-BASE02)
48 Points: 16-point I/O
96 Points: 32-point I/O

5-Slot Type



(NX70-BASE02)
80 Points: 16-point I/O
160 Points: 32-point I/O

6-Slot Type



(NX70-BASE02)
96 Points: 16-point I/O
192 Points: 32-point I/O

8-Slot Type



(NX70-BASE02)
128 Points: 16-point I/O
256 Points: 32-point I/O

10-Slot Type



(NX70-BASE02)
160 Points: 16-point I/O
320 Points: 32-point I/O

12-Slot Type



(NX70-BASE12)
192 Points: 16-point I/O
384 Points: 32-point I/O

Basic configurations and I/O

- **Flexible system configuration: 7 types of backplane (2-, 3-, 5-, 6-, 8-, 10- and 12-slot)**

The NX70 PLC has 7 types of backplane (2-, 3-, 5-, 6-, 8-, 10 and 12-slot type), providing you with very flexible I/O configuration.

All backplane, I/O, power supply, and specialty modules are available regardless of processor type.

- **Maximum 384 I/O points**

With 12-slot NX70 PLC, you can use up to 384 I/O points (using 32-point module). With terminal block type, up to 192 points are available (using 16-point module).

The backplane may have to be replaced when expanding the number of modules.

Module Types and Combinations

Combinations of backplane and modules

Backplane

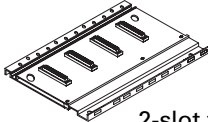

2-slot type (NX70-BASE02)

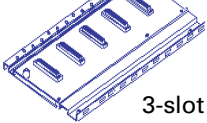

3-slot type (NX70-BASE03)

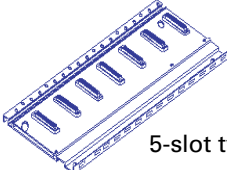

5-slot type (NX70-BASE05)

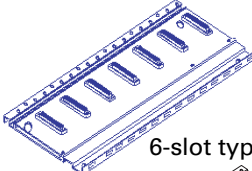

6-slot type (NX70-BASE06)

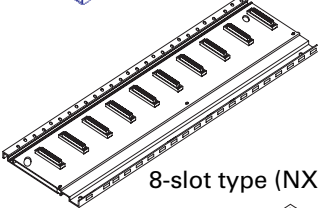

8-slot type (NX70-BASE08)

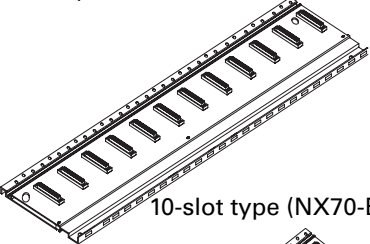

10-slot type (NX70-BASE10)

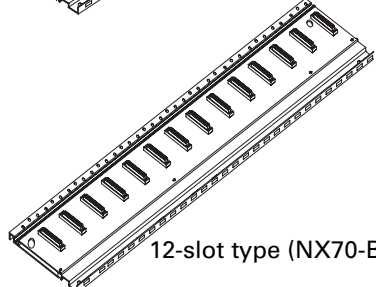

12-slot type (NX70-BASE12)



Processor module



NX70-CPU70p1
9.6k step base memory
1 port (RS232/RS485)



NX70-CPU70p2
20k step base memory
2 ports (RS232/RS485)

Power supply module



NX70-POWER1
110 to 220V ac Input
3.5A at 5V, 0.3A at 24V

NX70-POWER2
110 to 220V ac Input
4.0A at 5V

NX70-PWRDC
24V dc
4.0A at 5V

I/O module

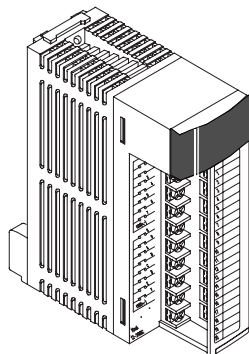

- **16-point input module**

24V dc IN (NX70-X16D)
 (NX70-X16D1)
 110V ac IN (NX70-X16A110)
 220V ac IN (NX70-X16A220)

- **8-point output module**

Relay OUT (NX70-Y8R)

- **16-point output module**

Relay OUT (NX70-Y16R)
 (NX70-Y16RV)
 Transistor OUT (NX70-Y16T)
 SSR OUT (NX70-Y16SSR)

- **16-point input/output module**

DC IN/Relay OUT (NX70-XY16)

- **32-points input/output module**

DC IN/Relay OUT (NX70-XY32)

- **32-point input module**

24V dc IN (NX70-X32D)
 (NX70-X32D1)

- **32-point output module**

Transistor OUT (NX70-Y32T)
 (NX70-Y32P)

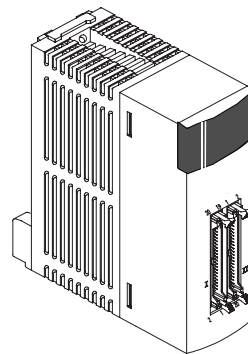

Specialty module

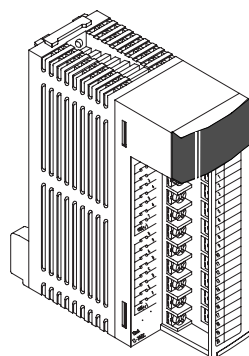

- **Analog input module**

4 channels, current/voltage input (NX70-AI4VC)

- **Analog output module**

4 channels, current output (NX70-AO4C)
 4 channels, voltage output (NX70-AO4V)
 2 channels, current output (NX70-AO2C)
 2 channels, Voltage output (NX70-AO2V)

- **RTD input module**

4 channels (NX70-RTD4)

- **TC input module**

4 channels (NX70-TC4)

- **High-speed counter**

2 channels (NX70-HSC2)
 1 channel (NX70-HSC1)

- **High-performance high-speed counter 4CH**

4 channels (NX70-HSC4)

- **Pulse output * module**

4 channels (NX70-PULSE4)

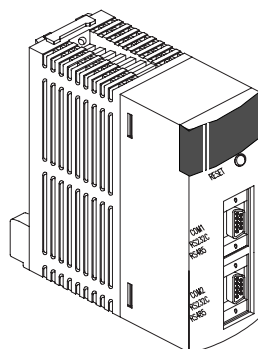
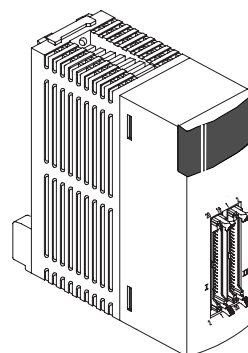

SCU module
 (NX70-SCU)

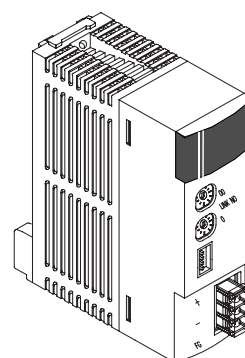

- **MW-link module** (NX70-MWLINK)
 Wire-Link function

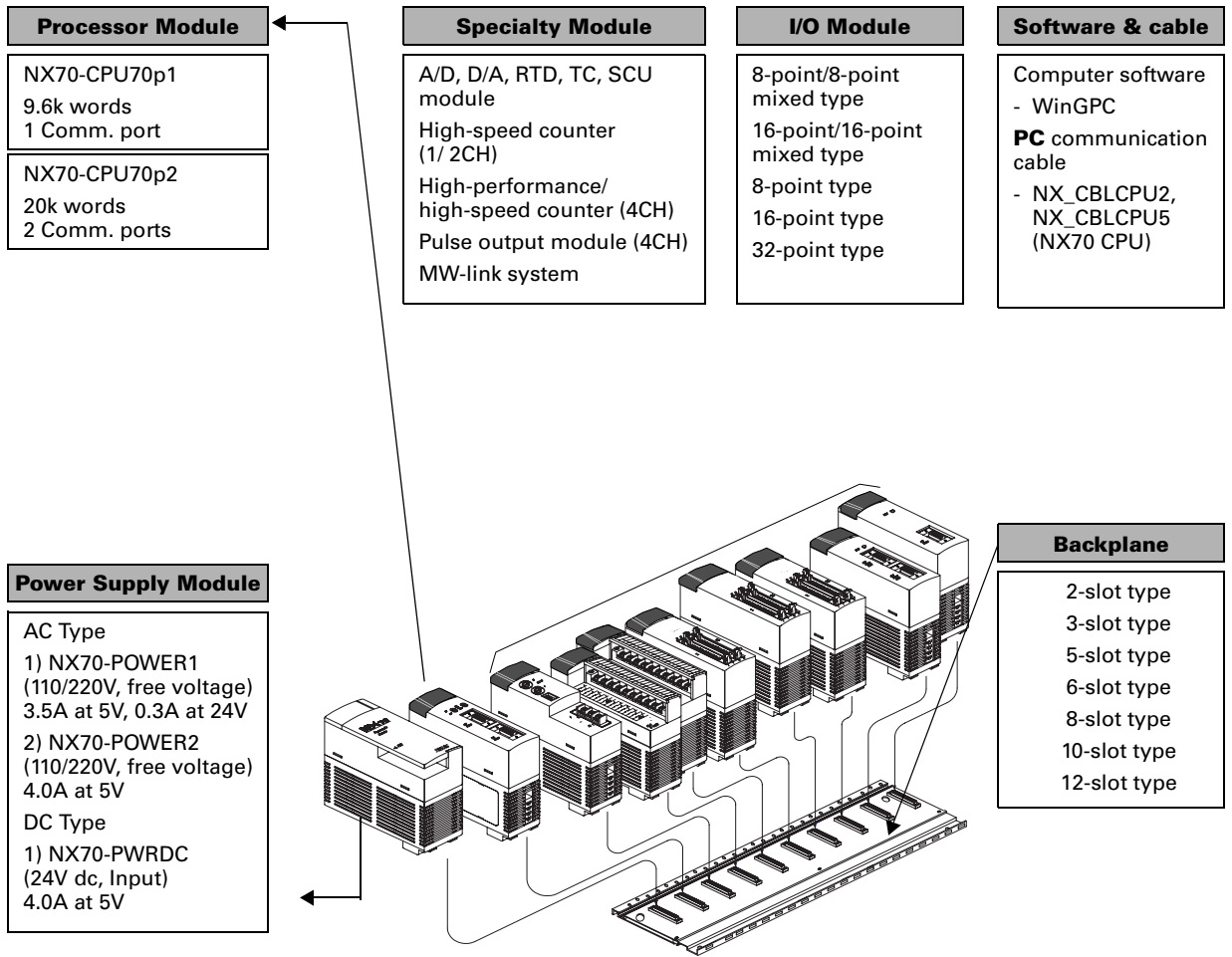

Limitations on current consumption

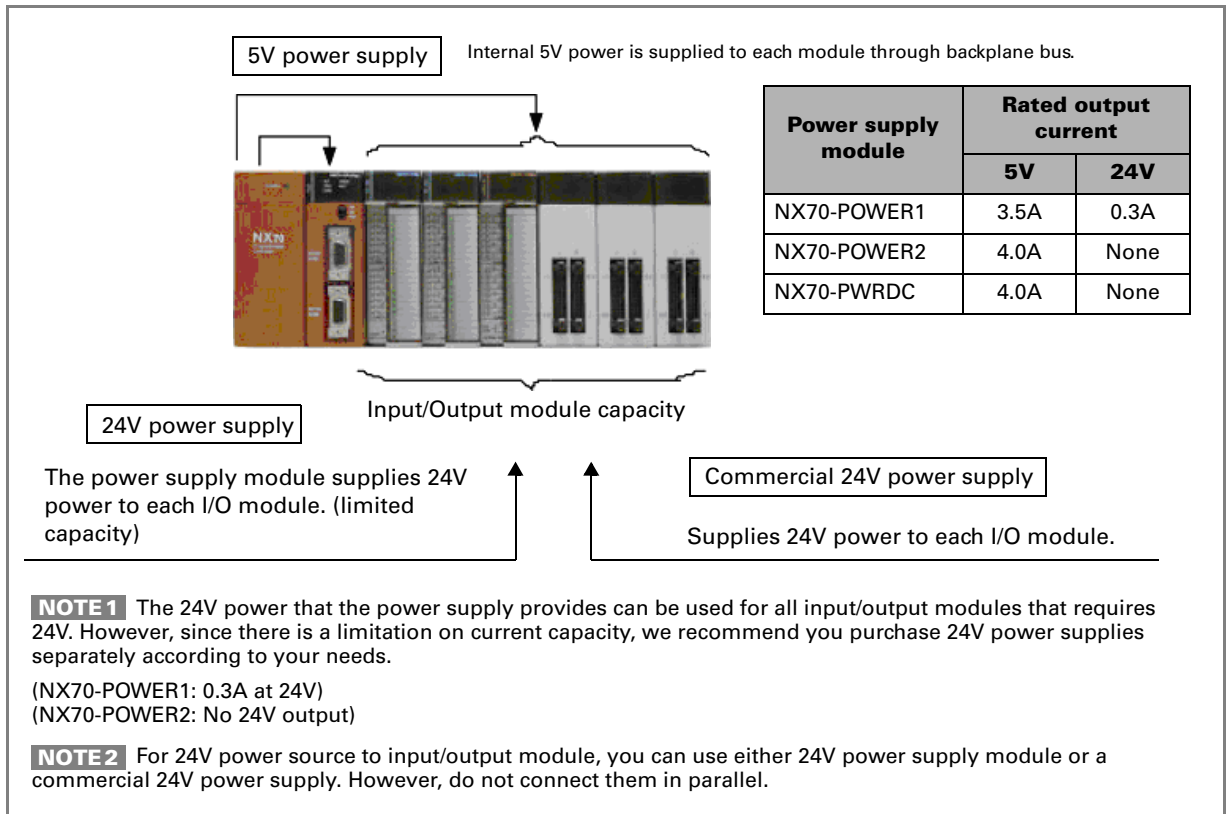

Use of internal and external power

- **5V internal power**

The 5V dc power used for driving the internal circuit of each module is supplied from the power supply module through the internal bus of the backplane. (No separate power supply is required.)

- **24V power**

The NX70-power1 24V dc power can be used for input power to input modules and driving output circuits of output modules.

For additional 24V power, you may also have to use another power supply module or a commercial power supply.

Do not connect together the NX70 power supply and a commercial power supply in parallel.

The NX70-POWER2 or the NX70-PWRDC modules do not provide 24V power. (Only 5V output is provided.)

- **Current consumption by each module**

Give considerations to current consumption by each module so that its power usage does not exceed the rated power usage at 5V or 24V dc.

Programming Tools

Tools required for programming

The following tools are required when programming with WinGPC.

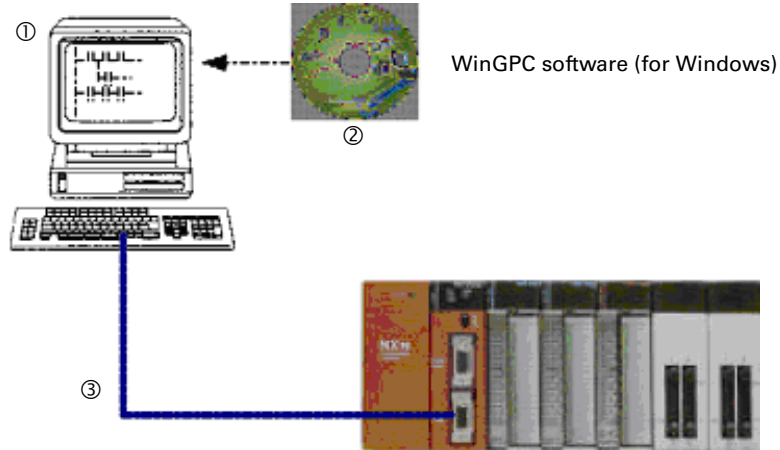

- ① Personal computer
- ② WinGPC (for Windows)
WinGPC is the programming tool for editing and debugging PLC programs for NX series controllers. WinGPC supports Microsoft Windows operating system.
- ③ Cable for programming
For connection to the communication port of the NX70 processor module, you can either purchase and use NX_CBLCPU2 or NX_CBLCPU5 cable or construct the needed cables as follows:

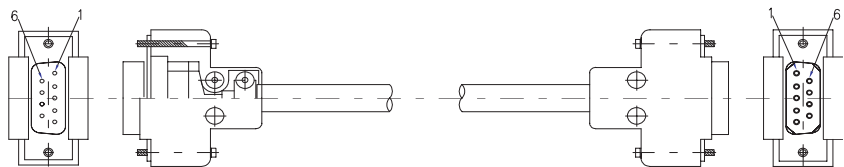

**Processor module
9-pin connector**

**Computer
9-pin connector**

Signal	Pin No.		Pin No.	Signal
TXD	2	—	2	RXD
RXD	3	—	3	TXD
-	4	—	4	DTR
S.G	5	—	5	S.G
485(-)	6	—	6	DSR
485(+)	7	—	7	RTS
-	8	—	8	CTS
VCC	9	—	9	-

Hardware Features and Specifications

Overall Specifications

General specifications

Item		Specifications
Temperature	Operating	0 °C to +55 °C (32 °F to 131 °F)
	Storage	-25 °C to +70 °C (-13 °F to 158 °F)
Humidity	Operating	30 to 85% RH (non-condensing)
	Storage	30 to 85% RH (non-condensing)
Withstand voltage		1500V ac for 1 minute between external terminal (ac) and frame ground (FG) 500V ac for 1 minute between external terminal (dc) and frame ground (FG)
Insulation resistance		100 MΩ or more at 500 mega V dc between external terminal and frame ground (FG)
Vibration immunity		10 to 55 Hz 1 sweep per minute, 0.75 mm peak to peak, 10 minutes per axis (X, Y, Z)
Shock immunity		10G 4 times for each X, Y, Z direction
Noise immunity		1500 Vp-p with 50 ns to 1 μs pulse width (generated by noise simulator)
Environment		IP 20

Dimensions (mm)

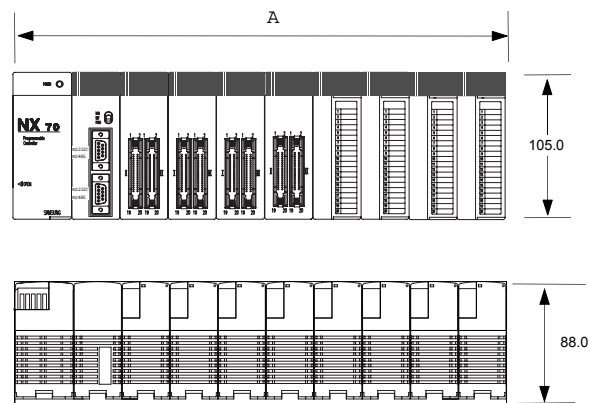

unit: mm

	NX70-BASE02	NX70-BASE03	NX70-BASE05	NX70-BASE06	NX70-BASE08	NX70-BASE10	NX70-BASE12
	2-slot type	3-slot type	5-slot type	6-slot type	8-slot type	10-slot type	12-slot type
A (mm)	149.5	185.0	256.0	291.5	362.5	398.0	433.5

Performance specifications

CPU type		NX70-CPU70p1	NX70-CPU70p2
Control method		Stored program, cyclic operation	
External I/O	Digital	384 points (32-point module/12 slots)	
	Analog	48 channels (4-channel module/12 slots)	
Instructions	Basic	28 types	
	Advanced	147 types	
Process speed	Basic instructions	0.2 μ s per step	
	Advanced instructions	1.0 to several tens of μ s per step	
Program capacity		9.6k words	20k words
Memory size	I/O (R)	R0.0 to R127.15 (2,048 points)	
	Link contact (L)	L0.0 to L63.15 (1,024 points)	
	Internal contact (M)	M0.0 to M127.15 (2,048 points) (Note: Available as link contact for NX70-CPU70p2, 64 words)	
	Keep contact (K)	K0.0 to M127.15 (2,048 points)	
	Special contact (F)	F0.0 to F15.15 (256 points)	
	Timer/Counter (TC or TIM)	256 channels (Timer + Counter), Set value range: 0 to 65535 Timer: 0.01 second: CH000 to CH063 (64 channels), 0.1 second: CH064 to CH255 (192 channels) Counter: CH000 to CH255 (256 channels)	
	Data register (W)	W0000 to W2047 (2,048 words)	W0000 to W2047, W3072 to W5119 (4,096 words)
	Special register (W, SR)	W256 (=SR000) to W3071 (=SR511) (512 words)	
Real time clock		Not Applicable	Year, Month, Date, Hour, Minute, Second, Day
Communication	Port 1	Supports both RS232 and RS485, 4800/9600/19200/38400 bps	
	Port 2	Not Applicable	Supports both RS232 and RS485, 4800 to 38400 bps Supports a user-defined protocol
Backup using flash ROM		Supports all (built-in CPU module)	

- Keep contact (K), data register (W), counter's preset value register retain their last values before power was removed.
- The super capacitor in the processor module backups all user programs and specific registers for up to 48 hours, even in the event of a power failure.

Backplane

The following backplanes are available: NX70-BASE02, NX70-BASE03, NX70-BASE05, NX70-BASE06, NX70-BASE08, NX70-BASE10, and X70-BASE12.

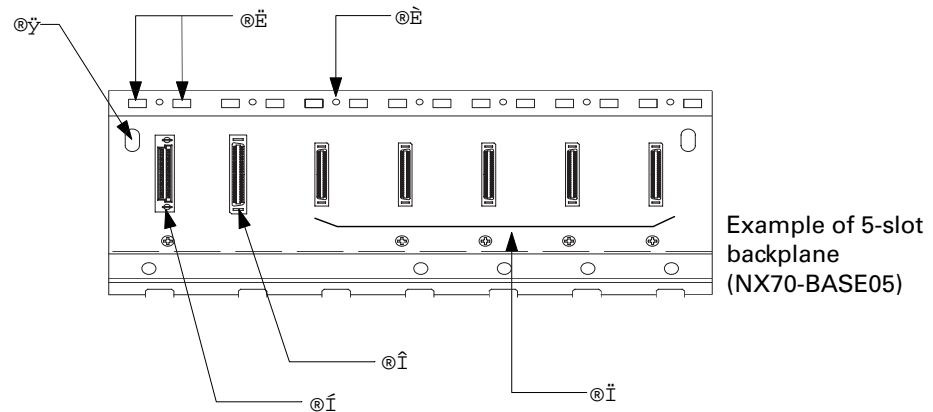

Hardware features

- ① Backplane mounting holes
Use these holes to mount the backplane to a control panel (control box). Use the M5 screw for mounting.
- ② Module guides
Align the tab on the module with one of these guides when installing the module to the backplane. Install modules onto the backplane starting from the leftmost guide in the order of power supply module, processor module, and I/O and/or specialty modules.
- ③ Module installation holes
Use these holes to secure the modules to the backplane. Use the screw supplied with the module for installation.
- ④ Connector for installing power supply module
- ⑤ Connector for installing processor module
This connector is used to install a processor module. Processor module must be installed next to the power supply module.
- ⑥ Connectors for installing I/O module (or specialty module)
These connectors are used to install I/O (specialty) modules.

Types of backplane

Slot number	Catalog number	Remarks
2	NX70-BASE02	
3	NX70-BASE03	
5	NX70-BASE05	
6	NX70-BASE06	
8	NX70-BASE08	
10	NX70-BASE10	
12	NX70-BASE12	

Processor Module

NX70-CPU70p1 processor module

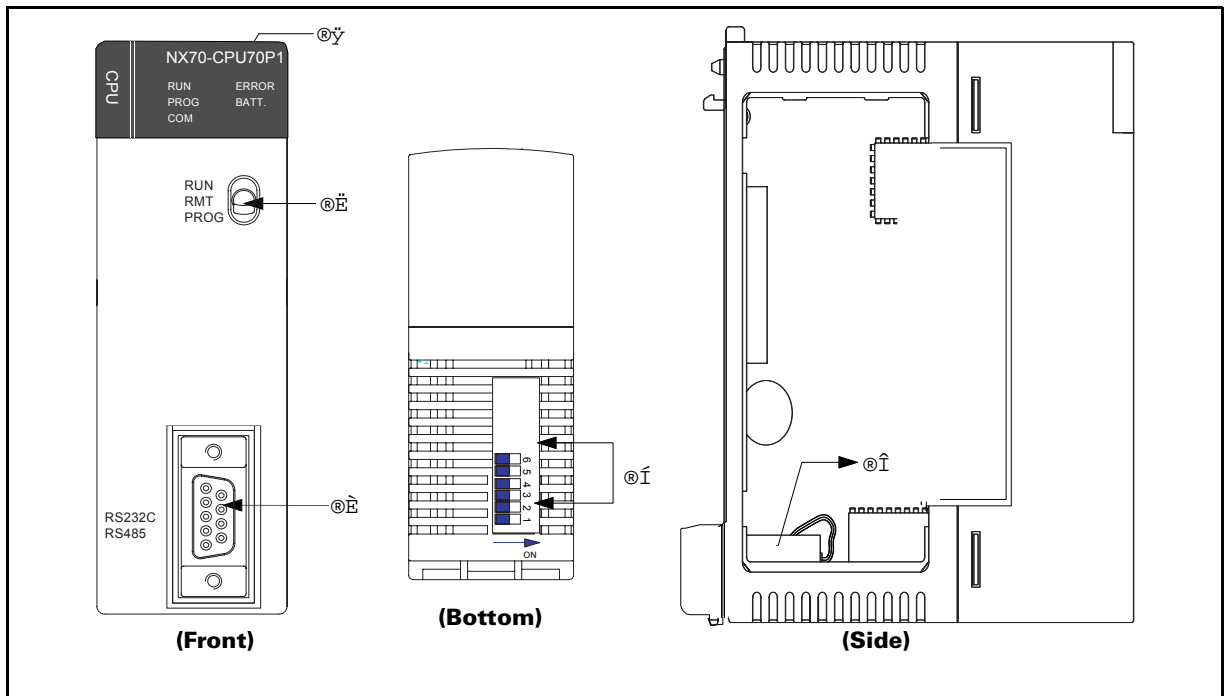

Hardware features

- ① Status LEDs
Display the operational status of the PLC such as the run, stop, error and alarm status.
- ② Operation mode selector switch
Used to change the operation mode of the controller.
- ③ RS232/RS485 communication port (9-pin COM port)
Used to connect to the programming tool (WinGPC) and/or touch panel.
- ④ Operating conditions setting switch
DIP switches for 6 poles, termination resistance setting, and communication and program booting method selection.
- ⑤ Backup battery for memory
Supplies a backup power to the built-in memory (RAM). The connector is not connected at shipping.

Status LEDs

Status LEDs		
LED	Color	Description
RUN	Green	On when the processor is running.
PROG	Green	On when the program can be edited.
COMM	Green	Flashing when the processor is communicating.
ERROR	Red	On when a processor error occurs.
BATT	Red	On when the battery is not mounted or is low.

Operation mode selector switch

Status	Description
RUN	Sets the processor operation mode to RUN mode.
RMT	Sets the processor operation mode to RUN or PROG mode.
PROG	Sets the processor operation mode to STOP mode, i.e., PROG mode.

Operating conditions setting switch

Pin No.	Pin setting	Description	DIP Switch	Remarks	
6	5	OFF OFF	Sets the communication speed to 9600 bps		Switches for setting communication and program booting methods
		ON OFF	Sets the communication speed to 19200 bps		
		OFF ON	Sets the communication speed to 38400 bps		
		ON ON	Sets the communication speed to 4800 bps		
4		OFF	Sets the communication method to RS-232C communications.		
		ON	Sets the communication method to RS-485 communications.		
3		OFF	When operating with the program stored in the built-in RAM.		
		ON	When operating with the program stored in flash ROM.		
2, 1	ON ON	For RS-485 communication, set both pins 1 and 2 to On if the system is an end-station.			
	OFF OFF	For RS-485 communication, set both pins 1 and 2 to Off if the system is not an end-station.	Switches for termination resistance setting		

NX70-CPU70p2 processor module

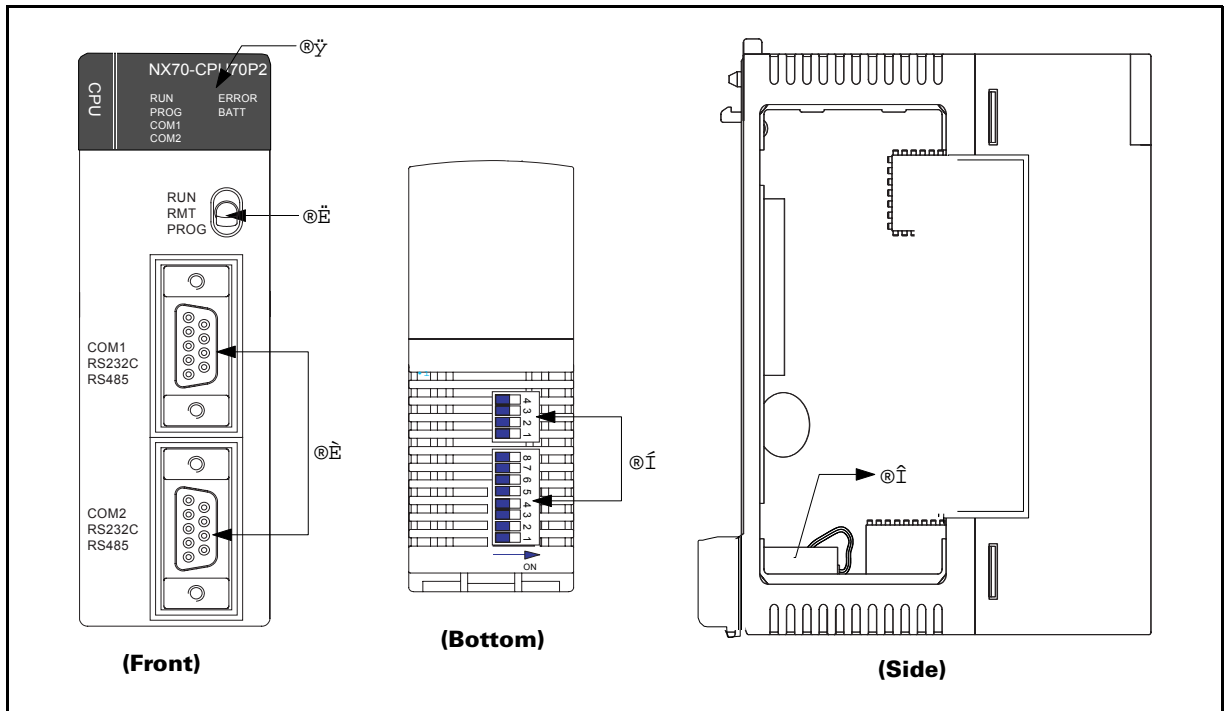

Hardware features

- ① Status LEDs
Displays the operational status of the PLC such as the run, stop, error and alarm status.
- ② Operation mode selector switch
Used to change the operation mode of the controller.
- ③ RS232/RS485 communication ports (9-pin COM1 and COM2 ports)
Used to connect to the programming tool (WinGPC), touch panel, or MMI. Allows user-defined communication. (COM2 port).
- ④ Operating conditions setting switch
DIP switch 1 (4 poles, termination resistance setting)
DIP switch 2 (8 poles, communication and program booting method setting)
- ⑤ Backup battery for memory
Supplies a backup power to the built-in memory (RAM). The connector is not connected at shipping.

Status LEDs

LED	Color	Description
RUN	Green	On when the processor is running.
PROG	Green	On when the program can be edited.
COM1	Green	Flashing when the processor is communicating via COM1.
COM2	Green	Flashing when the processor is communicating via COM2.
ERROR	Red	On when a processor error occurs.
BATT	Red	On when the battery is not mounted or is low.

Operation mode selector switch

Status	Description
RUN	Sets the processor operation mode to RUN mode.
RMT	Sets the processor operation mode to RUN or PROG mode.
PROG	Sets the processor operation mode to STOP mode, i.e., PROG mode.

Operating conditions setting switch

Switch for termination resistance setting (DIP switch 1)

Pin No.	Pin setting		Description	DIP Switch 1
3, 4	ON	ON	For RS-485 communication, set both pins 3 and 4 to On if the system is an end-station. (Enables termination for COM1 terminal)	
	OFF	OFF	For RS-485 communication, set both pins 3 and 4 to Off if the system is not an end-station. (Disables termination for COM1 terminal)	
1, 2	ON	ON	For RS-485 communication, set both pins 1 and 2 to On if the system is an end-station. (Enables termination for COM2 terminal)	
	OFF	OFF	For RS-485 communication, set both pins 1 and 2 to Off if the system is not an end-station. (Disables termination for COM2 terminal)	

Switch for communication and program booting method setting
(DIP switch 2)

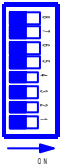
Pin No.	Pin setting		Description	DIP Switch 2
8, 7	OFF	OFF	Sets the communication speed on COM2 terminal to 9600 bps	
	ON	OFF	Sets the communication speed on COM2 terminal to 19200 bps	
	OFF	ON	Sets the communication speed on COM2 terminal to 38400 bps	
	ON	ON	Sets the communication speed on COM2 terminal to 4800 bps	
6, 5	OFF	OFF	Sets the communication speed on COM1 terminal to 9600 bps	
	ON	OFF	Sets the communication speed on COM1 terminal to 19200 bps	
	OFF	ON	Sets the communication speed of COM1 terminal to 38400 bps	
	ON	ON	Sets the communication speed on COM1 terminal to 4800 bps	
4	ON		Selects RS-485 communications for COM1	
	OFF		Selects RS-232C communications for COM1	
3	ON		Selects RS-485 communications for COM2	
	OFF		Selects RS-232C communications for COM2	
2	OFF		Always set to Off. (Used for system setting)	
1	ON		Loads the program from EEPROM (flash ROM) at power-on.	
	OFF		Operates the system with the program in RAM at power-on.	

Power Supply Module

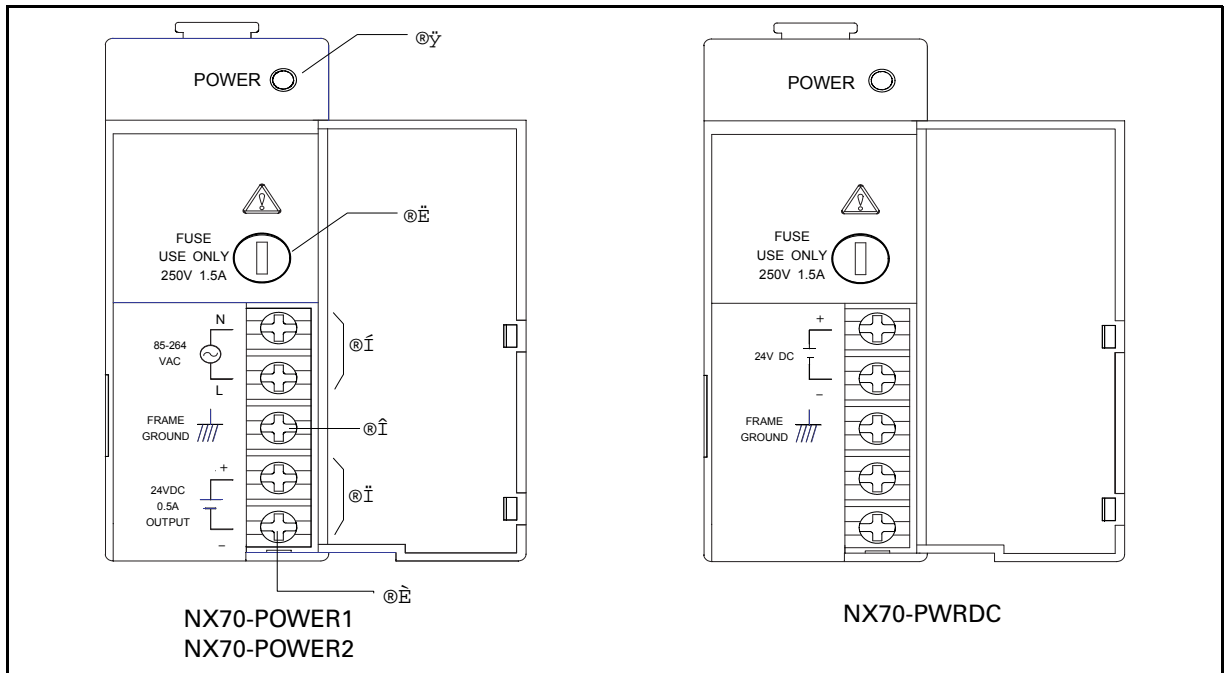

Hardware features

- ① Power status LED
Turns on when the power is supplied.
- ② Power fuse holder
- ③ Terminal block
Terminal block for power wiring. You can use M3.5 compressed screws for wiring.
- ④ Power input terminal
Input terminal for 110V to 240V ac, free voltage.
(However, NX70-PWRDC supplies 24V dc input power only.)
- ⑤ Frame ground (FG) terminal
As a grounding terminal, it is connected to the metal parts of the backplane. Use class 3 grounding to avoid electrical shock.
- ⑥ Power output terminal (24V dc)
Use this terminal when you need to supply 24V dc power to an I/O module.

ATTENTION

Do not connect this power output terminal with other commercial power supplies in parallel. It may cause error or product malfunction.



Specifications

Catalog number	NX70-POWER1	NX70-POWER2
Rated input voltage	110 to 220V ac, free voltage	
Allowable voltage range	85 to 264V ac	
Input power frequency	47 to 63 Hz	47 to 63 Hz
Inrush current	20A or less	20A or less
Rated output current	4.0A at 5V	4.5A at 5V
Rated output current	0.3A at 24V	Not applicable

Catalog number	NX70-PWRDC
Rated input voltage	24V dc
Allowable voltage range	21.6 to 26.4V dc
Rated output current	4.5A at 5V

NOTE The power supply module supplies 5V power to all modules mounted onto the backplane. Therefore, make sure that the current consumption of each module, which can use 5V power and/or 24V service power, does not exceed the rated range.

ATTENTION



NX70-POWER1 and NX70-POWER2 modules do not guarantee protection against momentary power failure at 110V ac.

ATTENTION



Make sure that total current consumption of all modules mounted on the backplane does not exceed the rated current capacity of the power supply module.

- 5V power is supplied from the power supply module mounted on the same backplane.
 - The 24V control power is used for supplying a dc power to I/O module.
 - Do not connect this 24V control power with other commercial power supplies in parallel. It may cause error or product malfunction.
 - A 250V 1A fuse is used for AC power. (The fuse is built into the power supply module.)
 - Be careful that the 24V side on the external terminal does not exceed the current capacity. (It may cause system errors.)
 - NX70-POWER1 and NX70-POWER2 modules do not guarantee protection against momentary power failure at 110V ac.
-

I/O Modules

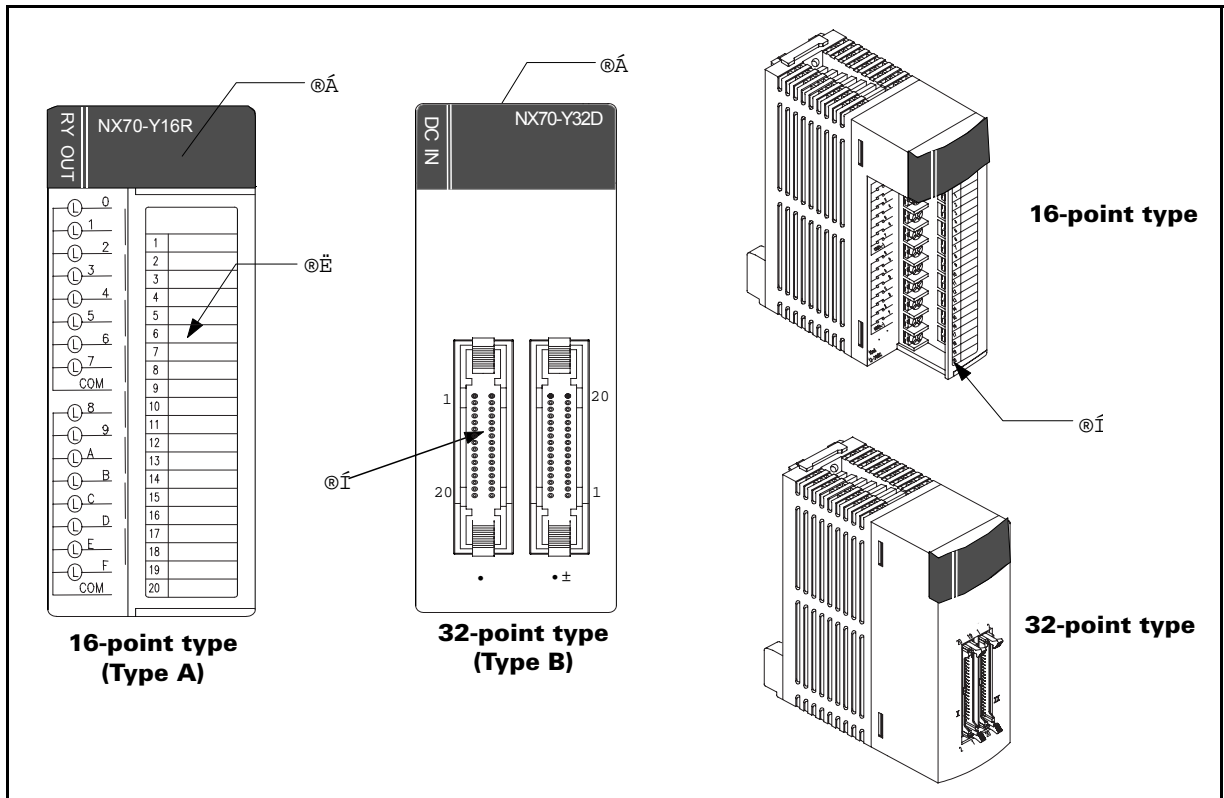

Hardware features

- ① I/O status LEDs
Displays the on/off state of I/O points.
- ② Terminal block (20 points)
Used for inputs, outputs and power supply wirings.
You can use M3.5 compressed screws for wiring.
For more information, refer to [Terminal Block Type Module Wiring on Chapter 4](#).
- ③ Two 20-pin connectors (32 points)
Used as connectors for input/output contacts and power supply wirings.
Use a flat cable or pin type harness.
For more information, refer to [Connector Type Module Wiring on Chapter 4](#).
- ④ Terminal block cover

Input module specifications

Product name		DC input module	
Catalog number		NX70-X16D	NX70-X16D1
Number of Input points		16 points	
Insulation method		Photocoupler	
Rated input voltage		12 to 24V dc	24V dc
Voltage range		10.2 to 26.4V dc	21.6V to 26.4V dc
Max. input current		10 mA or less	
On voltage		9.6V or more	20V or more
Off voltage		2.5V or less	7V or less
Input impedance		Approx. 3 K Ω	
Response time	Off \rightarrow On	2 ms or less	
	On \rightarrow Off	2 ms or less	
Internal current consumption		50 mA or less at 5V	
Common method		8 points per COM	
Status display		LED	
External connection method		Terminal block (terminal screw: M3.0)	
Suitable wire size		0.5 to 1.25 mm ²	
Weight		Approx. 160 g	
Shape		Type A	

Internal circuit and external wiring diagram

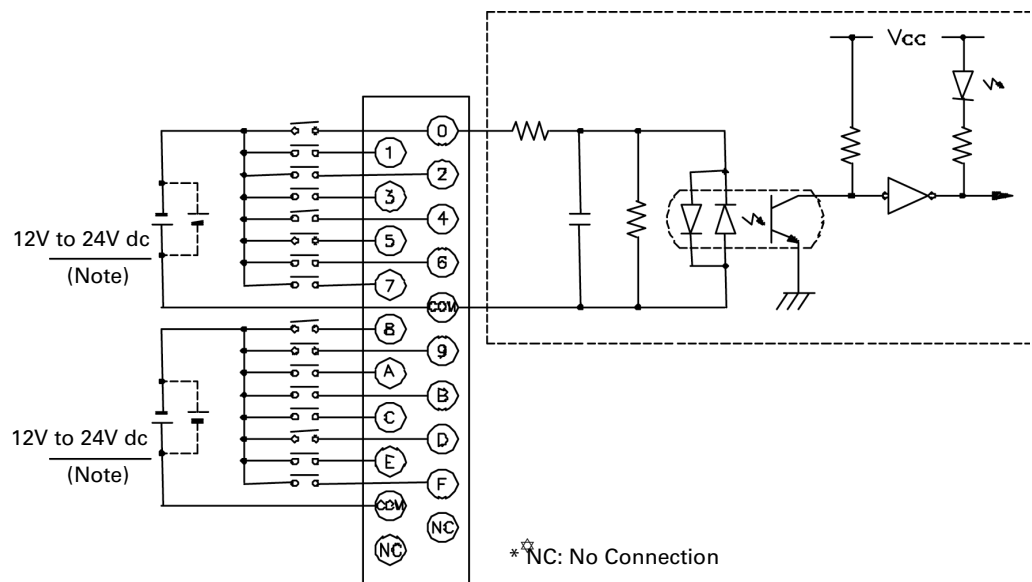

NOTE The input voltage of NX70-X16D1 module is 24V dc.

Product name		DC input module	
Catalog number		NX70-X32D	NX70-X32D1
Number of input points		32 points	
Insulation method		Photocoupler	
Rated input voltage		12 to 24V dc	24V dc
Voltage ranges		10.2 to 26.4V dc	21.6V to 26.4V dc
Max. input current		10 mA or less	
On voltage/current		9.6V or more	20V or more
Off voltage/current		2.5V or less	7V or less
Input impedance		Approx. 3 K Ω	
Response time	Off \rightarrow On	2 ms or less	
	On \rightarrow Off	2 ms or less	
Internal current consumption		90 mA or less at 5V	
Common method		8 points per COM	
Status display		LED	
External connection method		Two 20-pin connectors	
Suitable wire size		0.2 mm ²	
Weight		Approx. 130 g	
Shape		Type B	

Internal circuit and external wiring diagram

NOTE The numbers in the picture below (1 to 20) indicate the numbers that are printed on the front of each product.

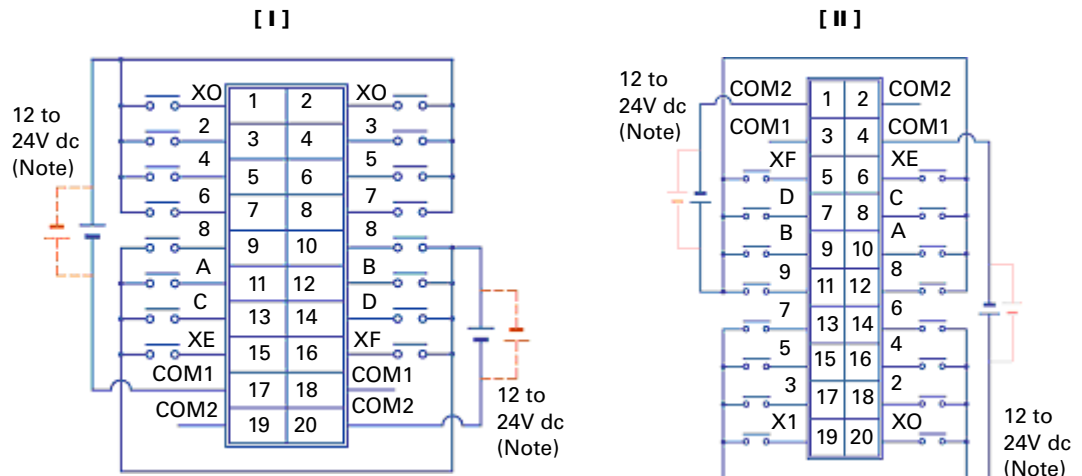

NOTE The input voltage of the NX70-X32D1 module is 24V dc.

- The internal circuit is the same as that of the NX70-X16D module on the previous page.
- The (I) and (II) connectors are positioned in opposite directions. Please use caution prior to connecting.
- For external connection of the connector, please purchase a cable harness NX70_CBLDC and a Pin Type Ass'y NX_PIN20. (For more information regarding the wiring methods, refer to [Connector Type Module Wiring on Chapter 4](#).)

Product name		AC input module	
Catalog number		NX70-X16A110	NX70-X16A220
Number of input points		16 points	
Insulation method		Photocoupler	
Rated input voltage		100 to 120V ac	200 to 240V ac
Voltage range		85 to 132V ac	170 to 264V ac
Max. input current		20 mA or less	
On voltage/current		80V or less / 6 mA or less	160V or less / 6 mA or less
Off voltage/current		30V or more / 3 mA or more	50V or more / 3 mA or more
Input impedance		Approx. 15 K Ω	Approx. 20 K Ω
Response time	Off \rightarrow On	15 ms or less	
	On \rightarrow Off	15 ms or less	
Internal current consumption		80 mA or less at 5V	
Common method		8 points per COM	
Status display		LED	
External connection method		Terminal block (terminal screw: M3.0)	
Suitable wire size		0.5 to 1.25 mm ²	
Weight		Approx. 160 g	
Shape		Type A	

Internal circuit and external wiring diagram

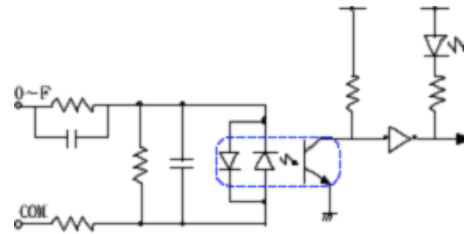
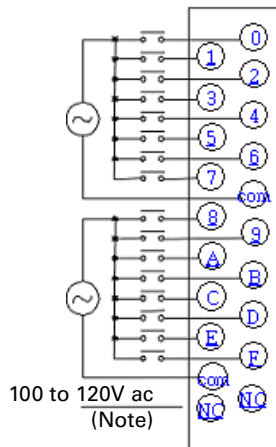

*NC: No Connection

NOTE The input voltage of NX70-X16D1 module is 24V dc.

Output module specifications

Product name		Relay output module		
Catalog number		NX70-Y8R	NX70-Y16R	NX70-Y16RV
Number of input points		8 points	16 points	
Insulation method		Photocoupler		
Rated load voltage		250V ac, 30V dc		
Load voltage range		85V to 264V ac		
Max. load current		3A per point	1A per point	
Response time	Off → On	10 ms or less		
	On → Off	10 ms or less		
External supply power		24V 150 mA or less	24V 150 mA or less	
Surge protection circuit		Varistor	Not applicable	Varistor
Internal current consumption		60 mA or less at 5V	100 mA or less at 5V	
Common method		4 points per COM, 1 points per COM x 4	8 points per COM	
Status display		LED		
External connection method		Terminal block (terminal screw: M3.0)		
Suitable wire size		0.5 to 1.25 mm ²		
Weight		Approx. 200 g	Approx. 300 g	
Shape		Type A		

Internal circuit and external wiring diagram

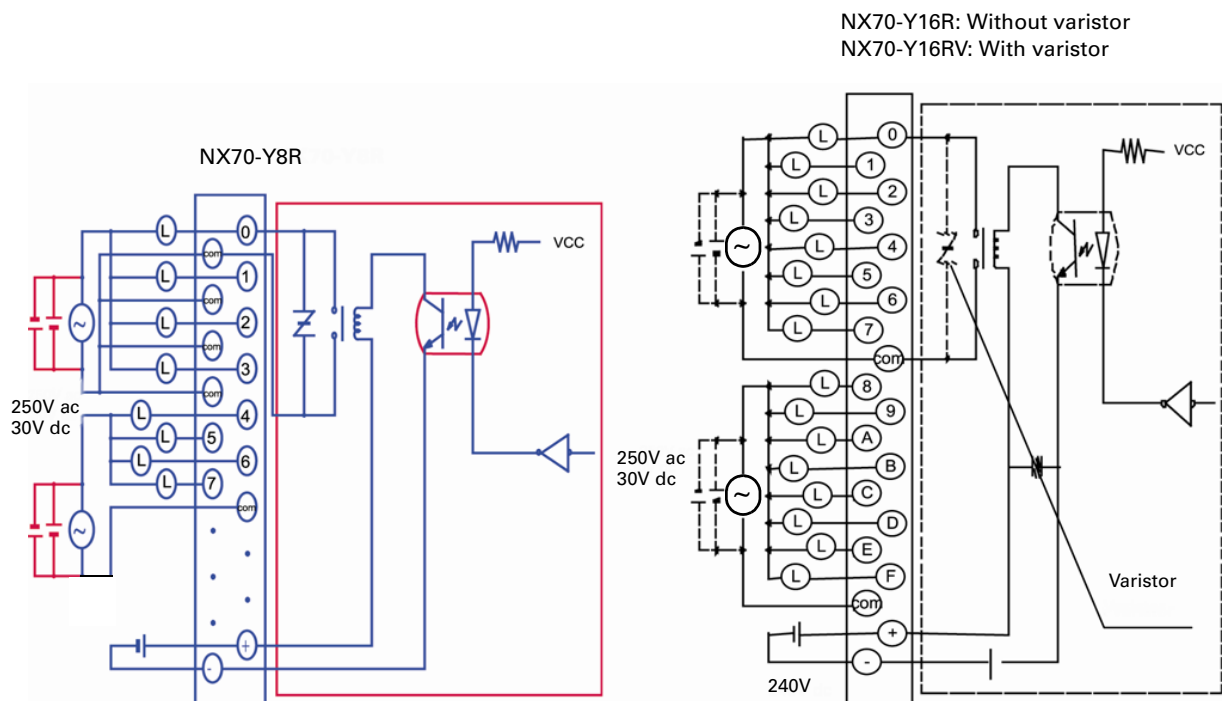

Product name		Transistor output module (NPN)
Catalog number		NX70-Y16T (NPN)
Number of input points		16 points
Insulation method		Photocoupler
Rated load voltage		12 to 24V DC
Load voltage range		10 to 30V AC
Max. load current		0.6A/point
Off state leak current		100 μ A or less
Response time	Off \rightarrow On	1 ms or less
	On \rightarrow Off	1 ms or less
Internal current consumption		80 mA or less at 5V
Surge absorber		Zener Diode
Common method		8 points per COM (-)
Status display		LED
External connection method		Terminal block (terminal screw: M3.0)
Suitable wire size		0.5 to 1.25 mm ²
Weight		Approx. 160 g
Shape		Type A

Internal circuit and external wiring diagram

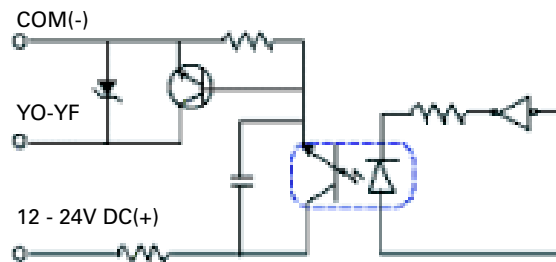
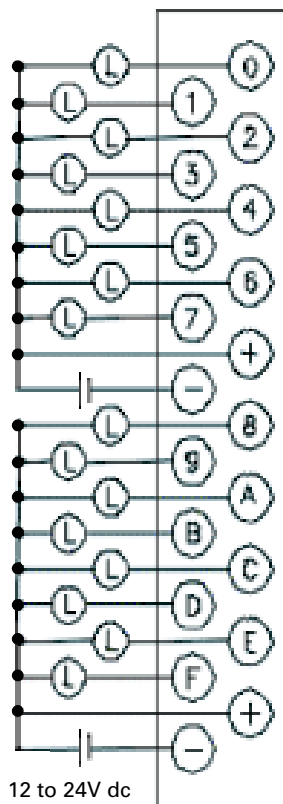

Product name		Transistor output module	
Catalog number		NX70-Y32T (NPN)	NX70-Y32P (PNP)
Number of input points		32 points	
Insulation method		Photocoupler	
Rated load voltage		12 to 24V dc	
Load voltage range		10 to 30V ac	
Max. load current		0.4A/point	
Off state leak current		100 μ A or less	
Response time	Off \rightarrow On	1 ms or less	
	On \rightarrow Off	1 ms or less	
Internal current consumption		140 mA or less at 5V	
Surge absorber		Zener Diode	
Common method		16 points per COM (-)	16 points per COM (+)
Status display		LED	
External connection method		Two 20-pin connectors	
Suitable wire size		0.2 mm ²	
Weight		Approx. 120 g	
Shape		Type B	

Internal circuit and external wiring diagram

NOTE The numbers in the picture below (1 to 20) indicate the numbers printed on the front of a product.

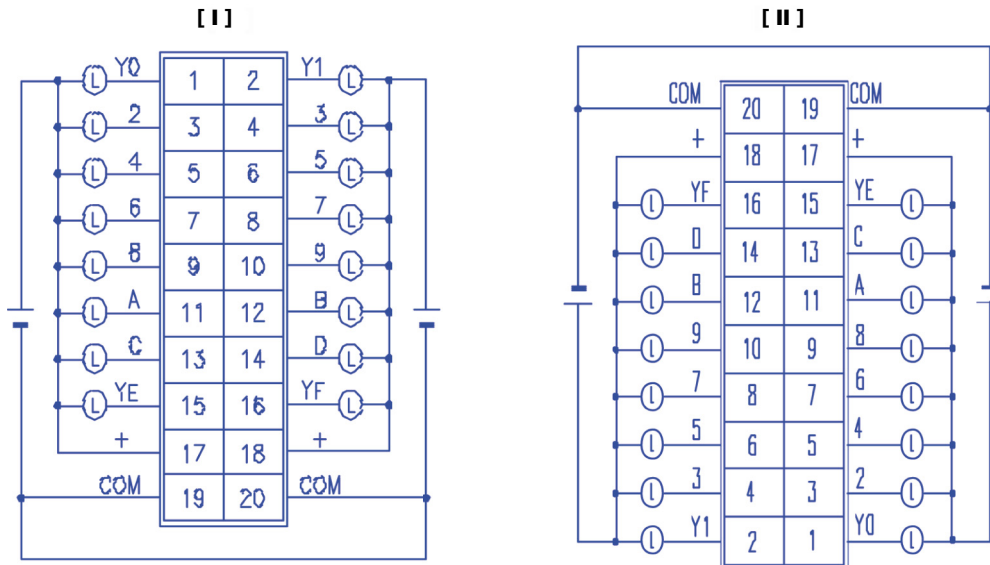

- The (I) and (II) connectors are positioned in opposite directions. Please use caution prior to connecting.
- For external connections of the connector, please purchase cable harness NX70_CBLDC and Pin Type Ass'y NX-PIN20. (For more information regarding the wiring methods, refer to [Connector Type Module Wiring on Chapter 4](#)).
- When wiring NX70-Y32P, please be cautious that the pins in the diagram picture and below are different.
 - Pin #17, #18: - (VDC-)
 - Pin #19, #20: COM (VDC+)

Product name		SSR output module
Catalog number		NX70-Y16SSR
Number of Input points		16 points
Insulation method		SSR
Rated load voltage		100 to 240V ac
Load voltage range		85 to 264V ac
Max. load current		0.5A/point
Off state leak current		100 μ A or less
Response time	Off \rightarrow On	1 ms or less
	On \rightarrow Off	0.5 cycle + 1 ms or less
Internal current consumption		250 mA or less at 5V
Rated fuse		3A
Common method		8 points per COM
Status display		LED
External connection method		Terminal block (terminal screw: M3.0)
Suitable wire size		0.5 to 1.25 mm ²
Weight		Approx. 300 g
Shape		Type A

Internal circuit and external wiring diagram

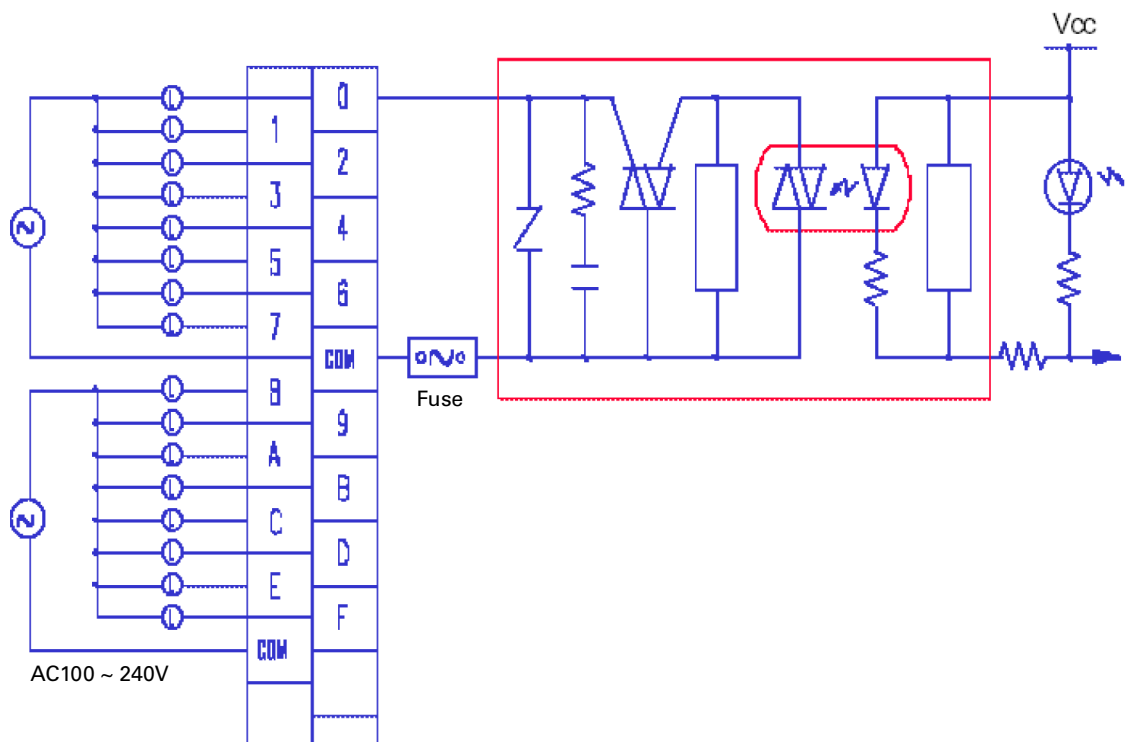

Product name		Mixed module of DC input/Relay output	
Catalog number		NX70-XY16	
Number of I/O points (16 points)		8 inputs (DC input)	8 outputs (Relay output)
Insulation method		Photocoupler	
Rated input voltage		12 to 24V dc	
Voltage range		10.2 to 26.4V dc	
Max. input current		10 mA or less	
Rated load voltage/current		250V ac, 30V dc, 1A/point	
On voltage/current		9.6V or less/4mA or less	
Off voltage/current		2.5V or less/1.5mA or less	
Input impedance		Approx. 3 K Ω	
External supply power		Not applicable	
Response time		10 ms or less	
Off \rightarrow On		10 ms or less	
On \rightarrow Off		10 ms or less	
Internal current consumption		80 mA or less at 5V	
Common method		8 points per COM (both + and - polarity are available)	8 points per COM
Status display		LED	
External connection method		Terminal block (terminal screw: M3.0)	
Suitable wire size		0.5 to 1.25 mm ²	
Weight		Approx. 220 g	
Shape		Type A	

Internal circuit and external wiring diagram

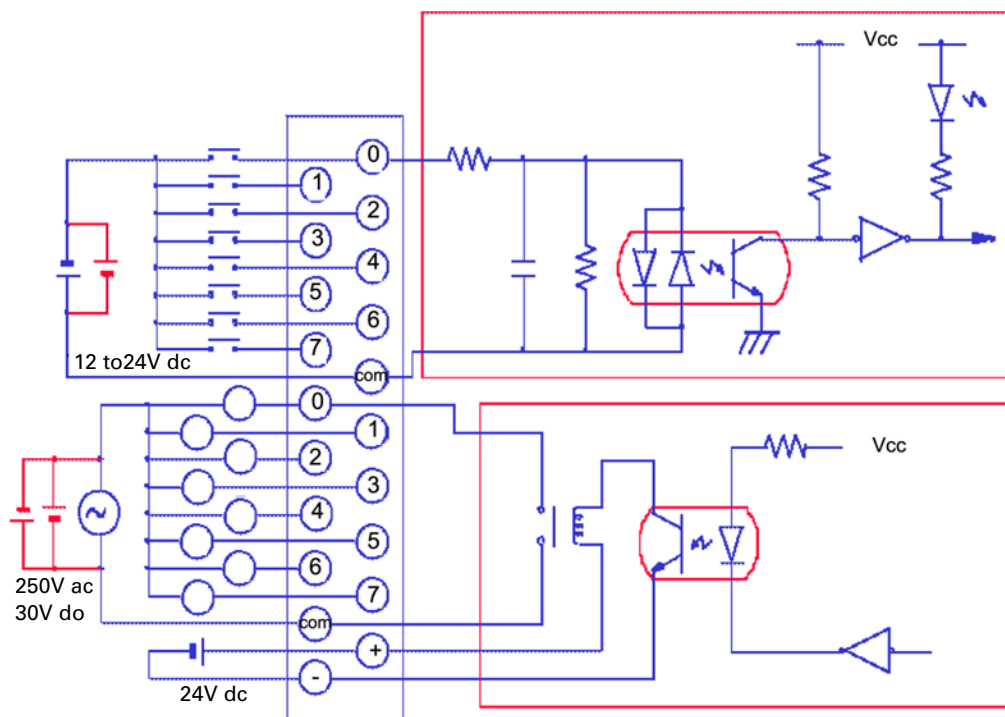

Product name		Mixed dc input/transistor output module	
Catalog number		NX70-XY32	
Number of I/O points (32 points)		16 inputs (DC input)	16 outputs (TR output, NPN)
Insulation method		Photocoupler	
Rated input voltage		12 to 24V dc	
Voltage range		10.2 to 26.4V dc	
Max. input current		10 mA or less	
Rated load voltage/current			10 to 30V ac, 0.4A/point
On voltage/current		9.6V or less / 4 mA or less	
Off voltage/current		2.5V or less / 1.5 mA or less	
Input impedance		Approx. 3 K Ω	
Surge absorber			Zener Diode
External supply power		Not applicable	24V 150 mA or less
Response time	Off \rightarrow On	10 ms or less	1 ms or less
	On \rightarrow Off	10 ms or less	1 ms or less
Internal current consumption		120 mA or less at 5V	
Common method		16 points per COM (both + and - polarities are available)	16 points per COM (-)
Status display		LED	
External connection method		Two 20-pin connectors	
Suitable wire size		0.2 mm ²	
Weight		Approx. 120 g	
Shape		Type B	

Internal circuit and external wiring diagram

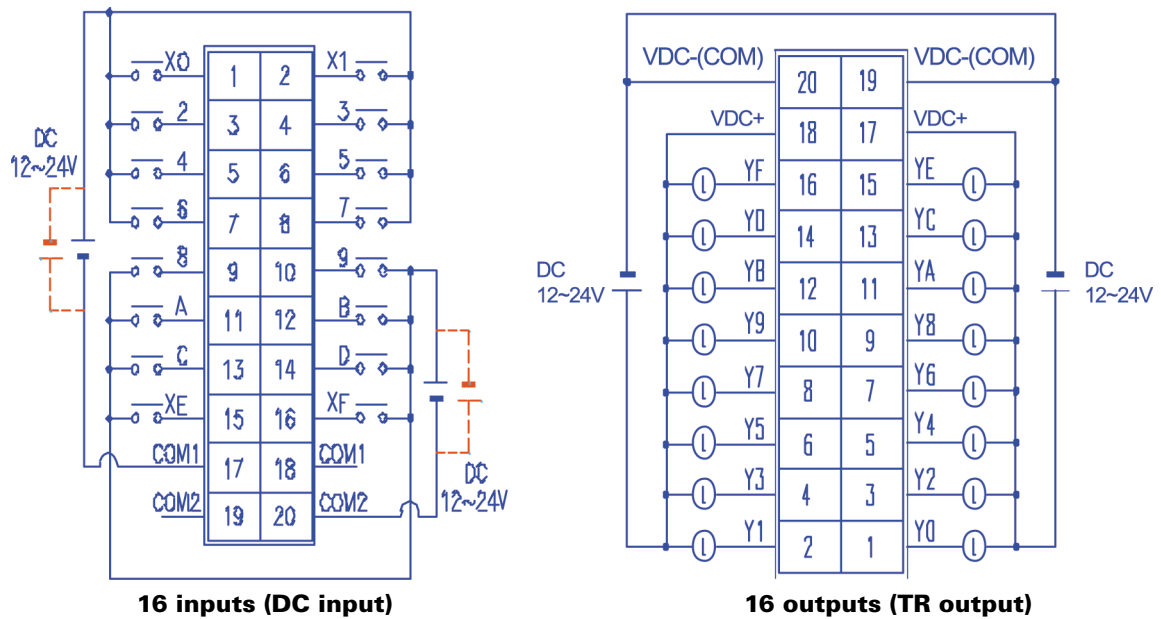

For external connections of the connector, please purchase cable harness NX70_CBLDC and Pin Type Ass'y NX-PIN20.
(For more information regarding the wiring methods, refer to [Connector Type Module Wiring on Chapter 4](#)).

Addressing Overview

Addressing Overview

All the memory used for external I/O processing and internal data processing has always both address and data (the content).

Addressing space is classified as R, L, M, K, F, TC, and W. These letters are used to designate a specific area in memory as shown in the following table.

Memory areas	Addresses	Description
External I/O area (R)	R0.0 to R127.15	<ul style="list-style-type: none"> Local I/O memory area that can be set when configuring I/O module. 2048 points, 128 words
	R0.0 to R127.15	<ul style="list-style-type: none"> Remote I/O memory area 2048 points, 128 words
Link contact (L)	L0.0 to L63.15	<ul style="list-style-type: none"> Link contact sharing memory area, 1024 points, Loop 0 Internal contact can be used when you do not use the link.
	M0.0 to M63.15	<ul style="list-style-type: none"> Link contact sharing memory area, 1024 points, Loop 1
Internal contact (M)	M0.0 to M127.15	<ul style="list-style-type: none"> Internal auxiliary contact memory area 2048 points, 128 words
Keep contact (K)	K0.0 to K127.15	<ul style="list-style-type: none"> Retentive internal auxiliary contact memory area 2048 points, 128 words Cleared when downloading a program.
Special contact (F)	F0.0 to F15.15	<ul style="list-style-type: none"> Special internal contact memory area 256 points, 16 words
Timer/Counter (TC)	TC000 to TC255 SV000 to SV255 PV000 to PV255	<ul style="list-style-type: none"> 256 channels common use (timer, counter) TC is contact signal. SV is Set Value, PV is Present Value. SV can hold values from 0 to 65535.
Data register (W)	W0 to W2047	<ul style="list-style-type: none"> Area that retains the data in case of power failure Bits are not addressable Cleared when downloading program
Special register (SR)	W3072 to W5119 SR000 to SR511	<ul style="list-style-type: none"> Special internal data area for CPU status and RTC

The R, L, M, K, F, and TC areas can be used for both bit and word addressing. The W area can be used to process word data only. The L area can be used as internal contacts. Keep contact (K), data register (W), and counter's preset value register retain their last values before power was removed. Cleared when a new program is downloaded.

A bit address is composed of a character (R, L, M, K, F) that identifies its type, a five digit word address (0.0 to 127.15, increases by 0 to 15). The timer/counter contact is represented by the TC label followed by three digits. The three digits indicate the channel number of the timer/counter (TC000 to TC255). TIM000 indicates a contact instead of TC000 for PGM10 and PGM-500.

A word address is composed of a character (R, L, M, K, W) and a four digit number (0000 to 2047). Special registers have alternative address representation. Special registers SR000 to SR511 can be also represented as W2560 to W3071.

Both of bit and word addresses can be used to address the memory areas of R, L, M, K. However, be cautious that instructions use a specific type of address, either bit or word address, and the used addresses are resolved automatically depending on the type of instruction.

A bit can have the content of either On (1) or Off (0) state. A word is composed of 16 bits and holds a data value from 0 to 65,535. A double word is composed of 32 bits and holds a data value from 0 to 4,294,967,295.

Expression example

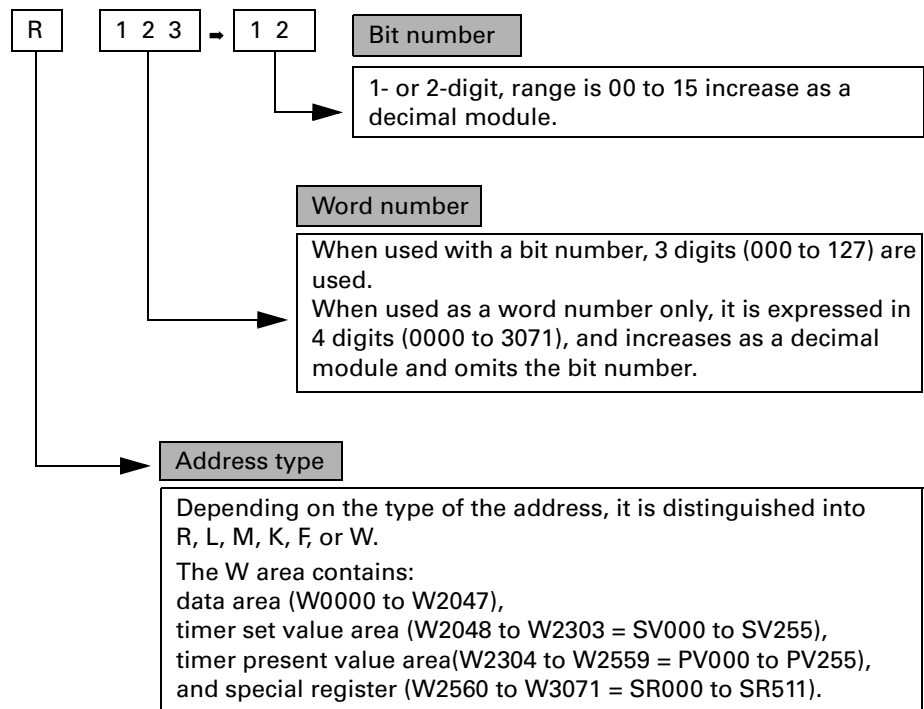

Double Word Addressing

Double word addressing is same with word addressing, except that 32-bit data is referenced by the specified address and its next address.

The type of instruction used determines which addressing, word or double word addressing, is applied. For comparison instructions, the programmer must be in "Double Mode" to enter a double-word comparison. For other instructions, those instructions that start with a D in front of the related word instruction are double word instructions, and the data is processed as double words

Example 1:

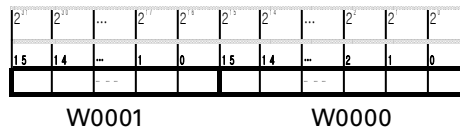
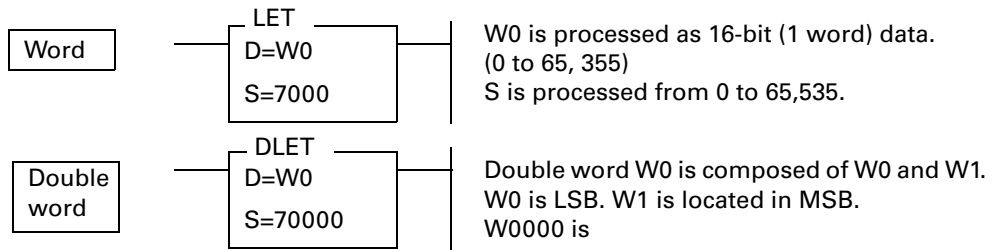

The value of D or S of the instruction can process data from 0 to 4,294,967,295.

Example 2:

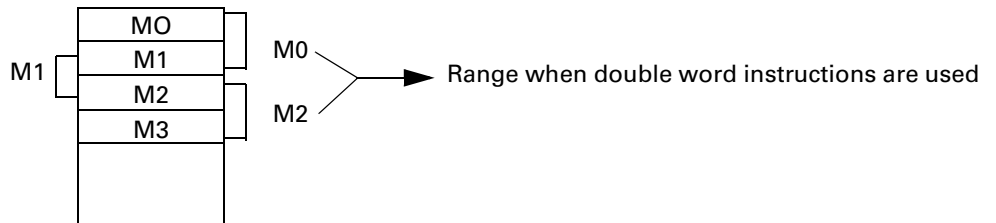

Absolute Addressing

In LDR, DLDR, STO, and DSTO instructions, an absolute address is used to indirectly reference a register or to utilize the built-in communication port.

Classification	Register address	Absolute address	
		Dec.	Hex.
External I/O	R0	0	0000
	R1	1	0001
	R2	2	0002

	R126	126	007E
	R127	127	007F
Link area	L0	128	0080
	L1	129	0081
	L2	130	0082

	L62	190	00BE
	L63	191	00BF
Internal contact	M0	192	00C0
	M1	192	00C1
	M2	194	00C2
	M3	195	00C3

	M126	318	013E
	M127	319	013F
Internal Keep contact	K0	320	0140
	K1	321	0141
	K2	322	0142
	K3	323	0143

	K126	446	01BE
	K127	447	01BF

Classification	Register address	Absolute address	
		Dec.	Hex.
Special Internal contact	F0	448	01C0
	F1	449	01C1
	F2	450	01C2

	F126	462	01CE
	F127	462	01CF
Data area	W0	512	0200
	W1	513	0201
	W2	514	0202

	W2046	2558	09FE
	W2047	2559	09FF
T/C set value	SV000	2560	0A00
	SV001	2561	0A01

	SV255	2815	0AFF
T/C present value	PV000	2816	0B00
	PV001	2817	0B01

Status	PV255	3071	0BFF
	SR000	3072	0C00
	SR001	3073	0C01

SR511	3583	0DFF	

An absolute bit address, which is often used in communication, consists of an absolute word address and a bit number (0 to 15, represented as \$0 to \$F) as shown below.

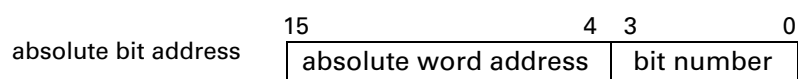

For example, the absolute bit address for internal contact K127.12 is \$1BFC (hex).

(\$1BFC = absolute word address \$01BF + bit number \$C)

I/O Addressing

Addressing is based on the location of the module.

Example 1: 8-slot system

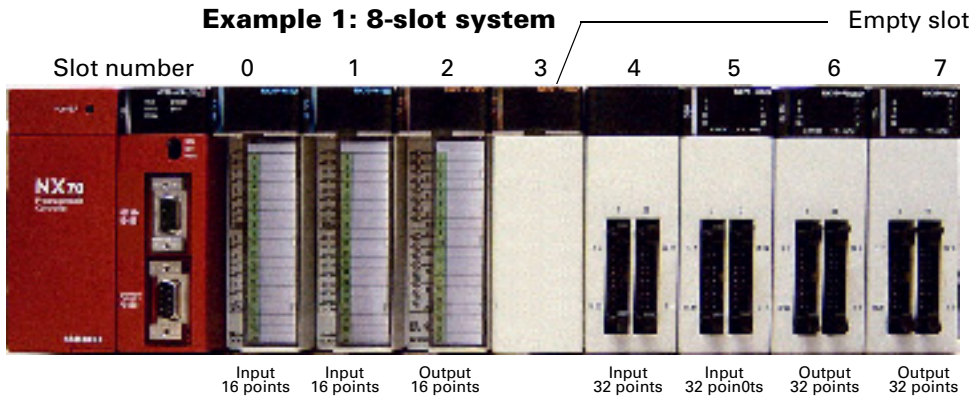

Example of addressing for the system shown above

Slot number		00	01	02	03	04	05	06	07
Word address		R0	R1	R2		R3 to R4	R5 to R6	R7 to R8	R9 to R10
Bit address	Processor module	R0.0 R0.1 ~ R0.15	R1.0 R1.1 ~ R1.15	R2.0 R2.1 ~ R2.15	Empty slot	R3.0 R3.1 ~ R4.15	R5.0 R5.1 ~ R6.15	R7.0 R7.1 ~ R8.15	R9.0 R9.1 ~ R10.15

Example 2: 10-slot system

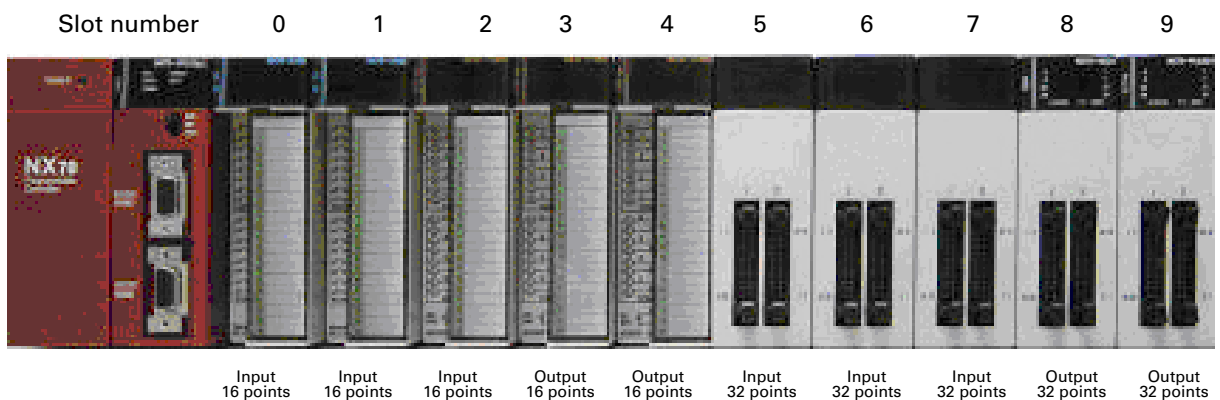

Example of addressing for the system shown above

Slot number		00	01	02	03	04	05	06	07	08	09
Word address		R0	R1	R2	R3	R4	R5 to R6	R7 to R8	R9 to R10	R11 to R12	R13 to R14
Bit address	CPU module	R0.0 R0.1 ~ R0.15	R1.0 R1.1 ~ R1.15	R2.0 R2.1 ~ R2.15	R3.0 R3.1 ~ R3.15	R4.0 R4.1 ~ R4.15	R5.0 R5.1 ~ R6.15	R7.0 R7.1 ~ R8.15	R9.0 R9.1 ~ R10.15	R11.0 R11.1 ~ R12.15	R13.0 R13.1 ~ R14.15

I/O addressing guidelines

The processor automatically distinguishes input address from output address for each module mounted.

A word address is allocated to a 16-point input or output module. For a 32-point mixed I/O module, 2 word addresses are allocated, a word address for inputs and another for outputs. For the 16-point mixed I/O module, 2 word addresses are allocated but only the lower 8 bits (0 to 7) of each word address can be used.

The modules mounted into the slots that are closer to the processor module have lower addresses.

An empty slot means no module is mounted and a blank module (NX-DUMMY) may be installed.

Occupied I/O points for each module

Module	Catalog number	Occupied I/O points
Input module	NX70-X16D	16 points
	NX70-X16D1	16 points
	NX70-X32D	32 points
	NX70-X32D1	32 points
	NX70-X16A110	16 points
	NX70-X16A220	16 points
Output module	NX70-Y8R	8 points
	NX70-Y16R	16 points
	NX70-Y16RV	16 points
	NX70-Y16T	16 points
	NX70-Y32T	32 points
	NX70-Y32P	32 points
	NX70-Y16SSR	16 points
Mixed I/O module	NX70-XY16	32 points
	NX70-XY32	32 points
MW-link module	NX70-MWLINK	0 points
SCU module	NX70-SCU	32 points
A/D module (4 channels)	NX70-AI4V	64 points or 16 points
	NX70-AI4C	
D/A module (2 channels)	NX70-AO2V	32 points or 16 points
	NX70-AO2C	32 points or 16 points
D/A module (4 channels)	NX70-AO4V	64 points or 16 points
	NX70-AO4C	64 points or 16 points
RTD module (4 channels)	NX70-RTD4	64 points or 16 points
TC module (4 channels)	NX70-TC4	64 points or 16 points
High-speed counter	NX70-HSC1	32 points
	NX70-HSC2	
High-performance high-speed counter	NX70-HSC4	64 points
Pulse output module	NX70-PULSE4	64 points

Special Registers

Word registers F000 to F15

Address	Function	Description	Remarks
F0 register	System check/control	System self-check/program checking, operation control	
F1 register	System check/clock	0.01/0.02/0.1 ms timer output, calculation results, carry flag	
F2 register	Link control	Link installation and operation mode setting	Loop #0
F3 register	Link control	Link installation and operation mode setting	Loop #1
F4 register	Link status flag	Link participating station information	Loop #0
F5 register	Link status flag	Link participating station information	Loop #1
F6 register	Link status flag	Link data receiving information flag	Loop #0
F7 register	Link status flag	Link data receiving information flag	Loop #1
F8 register	Remote control flag	Remote operation control flag	Loop #0
F9 register	Remote control flag	Remote operation control flag	Loop #1
F10 register	Remote control flag	Remote operation control flag	Loop #2
F11 register	Remote control flag	Remote operation control flag	
F12 register	User-defined communication flag	For port COM2 User-defined communication control flag	
F13 register	System reservation		
F14 register	PID control	PID operation mode and operation/stop control flag	Channel 0, 1, 2, and 3
F15 register	PID control	PID operation mode and operation/stop control flag	Channel 4, 5, 6, and 7

Word register F000 (F0.0 to F0.15)

Only a bit process is available.

Address	Function	Description	Normal status
F0.0	System check	When the power is applied, the system self-checks the ROM. Should any fault exist, the error lamp is turned on. Output and operation are halted.	OFF
F0.1	CPU ROM check	When the power is applied, the system self-checks the ROM. Should any fault exist, the error lamp is turned on. Output and operation are halted.	OFF
F0.2	CPU RAM check	When the power is applied, the system self-checks the RAM. Should any fault exist, the error lamp is turned on. Output and operation are halted.	OFF
F0.3	User program memory error	If the user program memory is damaged or the program is faulty, the error lamp is turned on. Output and operation are halted.	OFF
F0.4	Program syntax error	The CPU initially runs and checks the user program's syntax. In the case of an error, the error lamp is turned on. Output and operation are halted.	OFF
F0.5	Module range error	Indicates an invalid R word (>64) used.	OFF
F0.6	Module change error	On when an I/O module is removed/added/fails while the system is running. The error lamp is on and the CPU keeps running. Turned off when the error is corrected.	OFF
F0.7	Module type error	On when the I/O module information that is stored in the CPU and module that is installed are different types, the error lamp is turned on. Operation stops.	OFF
F0.8	Input data control	Off when the running CPU input module's data is not updated. (Input update is turned Off.)	ON
F0.9	Output data control	Off to suspend updating of the output modules while the CPU is in the Run state. (Output update is turned Off). The outputs are maintained in their last valid state prior to update being disabled.	ON
F0.10	All output off	Turns all outputs off while CPU is in the Run state. (Outputs are disabled)	ON
F0.11	Constant cycle interrupt	On when the constant cycle interrupt instructions are used. (Refer to the INT instructions.) (The cycle time is defined by the user.)	OFF
F0.12	Watchdog error	On when a scan time exceeds the watchdog set time.	OFF
F0.13	Disable module type checking	On when the CPU starts the initial Run and the program is checked without performing I/O module type verification.	
F0.14	Program changes during running	On when a user corrects the program while in Run mode. If there are any syntax errors, the CPU is stopped.	
F0.15	Run state control	On when the CPU is in the Run state. Off when stopped or paused.	ON

Word register F1 (F1.0 to F1.15)

Only a bit process is available.

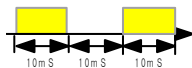
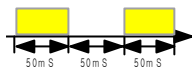
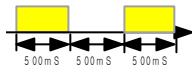
Address	Function	Description	Remarks
F1.0	First single scan	Maintain On state for first single-scan period, when the CPU changes its status stop to Run.	
F1.1	Scan clock	Cycle On/Off state for each scan during the program. (1Scan On, 1Scan Off)	
F1.2	0.02-second clock	10 ms: On, 10 ms: Off 	
F1.3	0.1-second clock	50 ms: On, 50 ms: Off 	
F1.4	1-second clock	500 ms: On, 500 ms: Off 	
F1.5	Instantaneous interrupt	On when power is off for 20 ms or more.	Maintained
F1.6	CPU running status	On when the CPU is in the run state.	
F1.7	Keep area error display	On when the K retentive data is destroyed and/or changed.	
F1.8	Carry flag	On in the event of carry when performing math instruction.	
F1.9	Division by zero error	On when the denominator of division commands is zero.	
F1.10	Range designation error	On when the absolute address exceeds the specified range.	
F1.11	Reserved	System use area	Do not use
F1.12	W area error indication	System use area	
F1.13	Reserved	System use area	Do not use
F1.14	Reserved	System use area	Do not use
F1.15	Reserved	System use area	Do not use

NOTE The 16 bits in the F1 address provide the CPU's special function and self-diagnosis result. They are used for status contacts only, and are not used to modify or control the PLC. Only the F1.5 instantaneous interrupt display contact should be used as an output contact by the user, to be turned off after power loss indication.

Word register F12 (F12.0 to F12.15)

Only a bit process is available.

Address	Function	Description	Remarks
F12.0	RTC check	On when the RTC is enabled.	-
F12.2	Flash	On when the 9.6 KW of flash memory is installed.	-
F12.3	Flash	On when the 16 KW of flash memory is installed.	-
F12.5	Battery error	On when the battery is not connected or the voltage is lower than the backup voltage.	-
F12.7	Periodical scan error	On when any error exists in the periodical program.	
F12.10	RTC set error	On when there is an error setting the RTC.	Output
F12.11	Saving Flash and checking boot	Off when the program is normally saved into Flash by setting F12.15 On.	Output
F12.12	EEPROM backup check	On when the program in EEPROM is the same with that in RAM.	
F12.13	RTC Set 1	On when you change the year, month, day, or date. Off when the data set is normal.	I/O
F12.14	RTC Set 2	On when you change the hour, minute, or second. Off when the data set is normal.	I/O
F12.15	Saving Flash	On when you save the current program into the flash. Off when the data set is normal.	I/O

Special registers SR0 to SR016 (W2560 to W2576)

May be modified - each is composed of 1 word.

Address	Function	Description
SR000	CPU ID number	Indicates the CPU ID number in the lower 8 bits. 0 to 223 are the valid user-defined values, 255 is the default value.
SR001	CPU state	Indicates current CPU information state. (run/stop/remote control/error) <div style="text-align: center; margin-top: 10px;"> </div>
SR2	Watchdog time	Indicates the user program watchdog time (unit: msec)
SR3	Scan time	Indicates the scan time when executing a program. Updated at every scan (unit: msec)
SR4	Max. scan time	Indicates maximum value of scan time when executing a program.
SR5 to SR7	Link module number	Link module number as set by the link # 1, 2, 3
SR8	PID table	PID register block start address
SR9 to SR10	Reserved	System use area
SR11 to SR16	Remote I/O information	Remote setup area

Special registers SR017 to SR511 (W2577 to W3071)

May be changed - each is composed of 1 word.

Address	Function	Description																				
SR017	System error information	<p>Gives result of self-diagnosis by CPU. Indicates error content .</p> <div style="text-align: center;"> <table border="1" style="margin: auto;"> <tr> <td style="text-align: center;">MSB ←</td> <td style="width: 15px; height: 15px;"></td> <td style="width: 15px; height: 15px;"></td> <td style="width: 15px; height: 15px;"></td> <td style="width: 15px; height: 15px;"></td> <td style="width: 15px; height: 15px;"></td> <td style="width: 15px; height: 15px;"></td> <td style="width: 15px; height: 15px;"></td> <td style="width: 15px; height: 15px;"></td> <td style="width: 15px; height: 15px;"></td> </tr> <tr> <td></td> <td style="text-align: center;">7</td> <td style="text-align: center;">6</td> <td style="text-align: center;">5</td> <td style="text-align: center;">4</td> <td style="text-align: center;">3</td> <td style="text-align: center;">2</td> <td style="text-align: center;">1</td> <td style="text-align: center;">0</td> <td></td> </tr> </table> </div> <p> Watchdog time error = ON ← Undefined instruction = ON ← Peripheral device fault = ON ← Misc. logic faults = ON ← Logic circuit fault = ON ← Microcomputer fault = ON ← </p>	MSB ←											7	6	5	4	3	2	1	0	
MSB ←																						
	7	6	5	4	3	2	1	0														
SR018	Location of undefined instruction	Indicates the location of the instruction (the step number) that caused an undefined instruction error during program execution.																				
SR019	Reserved	System use area																				
SR020	Multiplication	Stores high order bit values upon executing 16 bit multiplication instructions.																				
SR021	Lower remainder	Stores the low order bit values of remainder after a division instruction has been executed.																				
SR022	Higher remainder	Stores the high order bit values of the remainder after a division instruction has been executed.																				
SR023 to SR027	Reserved	System use area																				
SR028 to SR029	Defective slot information	Location of defective slots mounted onto the basic slot																				
SR030 to SR048	Reserved	System use area (syntax information and system information)																				
SR49 to SR79	Slot information	Stores slot information for installed I/O modules.																				
SR261 to SR279 *	Remote control domain	Contains remote I/O configuration data.																				
SR289 to SR297	RTC	Contains real time clock information (year, month, day, hour, minute, second, date).																				
SR298 to SR373 *	User-defined communication area	For port COM2 User-defined communication area																				
SR374 to SR379 *	Link error information	Link error information data.																				
SR380 to SR511	Reserved	System use area																				

* Applied when using communication modules

Program syntax error status register SR30 (W2590)

Indicates the result of the automatic check on the user program syntax when the programmer or GPC executes a syntax check, and when the operation mode is switched from the Stop state to the Run state. If the value of W2590 is not zero, F004 bit turns On. The error lamp also turns On.

Error correction method:

Find the error in the CPU online mode and then correct the program.

Word	Bit	Description
SR30	0	On if the I/O number range of bit process instruction is beyond the specified range or designates an external contact/output module which is not installed.
	1	On if the channel number of the timer or the counter exceeds 255 or is duplicated.
	2	On if the bit or word number in the advanced instruction is beyond the specified range or if it designates a module which is not installed.
	3	On if a word number in the refresh instruction (INPR, OUTR) is beyond the specified range, or if it designates a module which is not installed.
	4	On if an undefined instruction exists.
	5	On in event of a user program memory writing error.
	6	On in event of miscellaneous errors.
	7	On if the user program memory is abnormal.
	8	On if an error on external I/O address and bit/word/double word numbers used occurs. For example, the first slot is set with an input module and OUT R00001 is designated.
	9	On if the label numbers of the JMP or CALL instructions exceed 63, the corresponding instruction LBL or SBR does not exist, and/or the corresponding LBL/SBR instructions exist prior to JMP/CALL instructions.
	10	On if the label number of the LBL instruction exceeds 63 and/or is duplicated.
	11	On if the JMPS/JMP instructions are mistakenly combined and/or used.
	12	On if the FOR/NEXT instructions are mistakenly combined and/or used more than four times. (Loop)
	13	On if SBR/RET instructions are not combined and/or used and/or the SBR instructions overlap or exceed 63.
	14	On if NT/RETI instructions are not combined and/or used and/or more than two sets of INT instructions are used.
15	On if no END instruction inserted automatically.	

Real-time clock registers SR289 to SR297 (W2849 to W2857)

Sets the time of the built-in clock (RTC) and stores and displays the present time. Data is stored in BCD format.

(○ : bit = 0; x: bit change)

Classification	Address	Bit address Adjustment/ indication	Details															
			15	14	13	12	11	10	9	8	7	6	5	4	3	2	1	0
Current time	SR289	Year (4-digit BCD)																
	SR290	Date: day	○	○	x	x	x	x	x	x	○	○	○	○	○	x	x	x
	SR291	Year: month	○	x	x	x	x	x	x	x	○	○	○	x	x	x	x	x
	SR292	Second: 00	○	○	x	x	x	x	x	x	○	○	○	○	○	○	○	○
	SR293	Hour: minute	○	○	x	x	x	x	x	x	○	○	○	○	○	○	○	○
Time setting	SR294	Date: day	○	○	x	x	x	x	x	x	○	○	○	○	○	x	x	x
	SR295	Year: month	○	x	x	x	x	x	x	x	○	○	○	x	x	x	x	x
	SR296	Second: 00	○	○	x	x	x	x	x	x	○	○	○	○	○	○	○	○
	SR297	Hour: minute	○	○	x	x	x	x	x	x	○	○	○	○	○	○	○	○

* Usable for NX70-CPU70p2 module only

In SR289, the year can be read in a 4-digit BCD.

Ex) \$1998=1998, \$2000=2000

SR289 to SR297 for clock functions are shown in BCD, so it is convenient to confirm in HEX.

NOTE Set the range as follows:

Year: 00 to 99, Month: 01 to 12, Day: 01 to 31, Day of Week: 01 to 07 (Sun. to Sat.)

Hour: 00 to 23, Minute: 00 to 59, Second: 00 to 59

1. Ladder setting method:

For example, current date and time are: Tuesday, March 21, 1996, 18:35:07

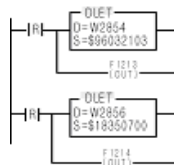
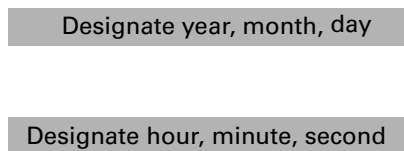

Date indicators are Sun (01), Mon (02), Tue (03), Wed (04), Thu (05), Fri (06), and Sat (07)

2. When changing the year, month, date, or day, new data is input in SR295, SR294, then the F12.14 bit is turned On. The F12.10 bit is kept Off.
3. When changing the hour, minute, and second, new data is input in SR297, SR296, then the F12.14 bit is turned on. If the new data is not set correctly, the F12.10 bit turns on.
4. The display date and set value are expressed in BCD so it is convenient to input as hex (\$).
5. The year, month, and day are automatically changed.

Timer/Counter Area

Timer/counter set value and present value addresses

Channel	Set value (SV)	Present value (PV)	Channel	Set value (SV)	Present value (PV)	Channel	Set value (SV)	Present value (PV)
0	W2048	W2304	40	W2088	W2344	80	W2128	W2384
1	W2049	W2305	41	W2089	W2345	81	W2129	W2385
2	W2050	W2306	42	W2090	W2346	82	W2130	W2386
3	W2051	W2307	43	W2091	W2347	83	W2131	W2387
4	W2052	W2308	44	W2092	W2348	84	W2132	W2388
5	W2053	W2309	45	W2093	W2349	85	W2133	W2389
6	W2054	W2310	46	W2094	W2350	86	W2134	W2390
7	W2055	W2311	47	W2095	W2351	87	W2135	W2391
8	W2056	W2312	48	W2096	W2352	88	W2136	W2392
9	W2057	W2313	49	W2097	W2353	89	W2137	W2393
10	W2058	W2314	50	W2098	W2354	90	W2138	W2394
11	W2059	W2315	51	W2099	W2355	91	W2139	W2395
12	W2060	W2316	52	W2100	W2356	92	W2140	W2396
13	W2061	W2317	53	W2101	W2357	93	W2141	W2397
14	W2062	W2318	54	W2102	W2358	94	W2142	W2398
15	W2063	W2319	55	W2103	W2359	95	W2143	W2399
16	W2064	W2320	56	W2104	W2360	96	W2144	W2400
17	W2065	W2321	57	W2105	W2361	97	W2145	W2401
18	W2066	W2322	58	W2106	W2362	98	W2146	W2402
19	W2067	W2323	59	W2107	W2363	99	W2147	W2403
20	W2068	W2324	60	W2108	W2364	100	W2148	W2404
21	W2069	W2325	61	W2109	W2365	101	W2149	W2405
22	W2070	W2326	62	W2110	W2366	102	W2150	W2406
23	W2071	W2327	63	W2111	W2367	103	W2151	W2407
24	W2072	W2328	64	W2112	W2368	104	W2152	W2408
25	W2073	W2329	65	W2113	W2369	105	W2153	W2409
26	W2074	W2330	66	W2114	W2370	106	W2154	W2410
27	W2075	W2331	67	W2115	W2371	107	W2155	W2411
28	W2076	W2332	68	W2116	W2372	108	W2156	W2412
29	W2077	W2333	69	W2117	W2373	109	W2157	W2413
30	W2078	W2334	70	W2118	W2374	110	W2158	W2414
31	W2079	W2335	71	W2119	W2375	111	W2159	W2415
32	W2080	W2336	72	W2120	W2376	112	W2160	W2416
33	W2081	W2337	73	W2121	W2377	113	W2161	W2417
34	W2082	W2338	74	W2122	W2378	114	W2162	W2418
35	W2083	W2339	75	W2123	W2379	115	W2163	W2419
36	W2084	W2340	76	W2124	W2380	116	W2164	W2420
37	W2085	W2341	77	W2125	W2381	117	W2165	W2421
38	W2086	W2342	78	W2126	W2382	118	W2166	W2422
39	W2087	W2343	79	W2127	W2383	119	W2167	W2423

NOTE If you change the above registers while the program is running or program them incorrectly, errors or damage may occur. Be sure you understand the programming procedures of the timer/counter thoroughly.

Channel	Set value (SV)	Present value (PV)	Channel	Set value (SV)	Present value (PV)	Channel	Set value (SV)	Present value (PV)
120	W2168	W2424	166	W2214	W2470	212	W2260	W2516
121	W2169	W2425	167	W2215	W2471	213	W2261	W2517
122	W2170	W2426	168	W2216	W2472	214	W2262	W2518
123	W2171	W2427	169	W2217	W2473	215	W2263	W2519
124	W2172	W2428	170	W2218	W2474	216	W2264	W2520
125	W2173	W2429	171	W2219	W2475	217	W2265	W2521
126	W2174	W2430	172	W2220	W2476	218	W2266	W2522
127	W2175	W2431	173	W2221	W2477	219	W2267	W2523
128	W2176	W2432	174	W2222	W2478	220	W2268	W2524
129	W2177	W2433	175	W2223	W2479	221	W2269	W2525
130	W2178	W2434	176	W2224	W2480	222	W2270	W2526
131	W2179	W2435	177	W2225	W2481	223	W2271	W2527
132	W2180	W2436	178	W2226	W2482	224	W2272	W2528
133	W2181	W2437	179	W2227	W2483	225	W2273	W2529
134	W2182	W2438	180	W2228	W2484	226	W2274	W2530
135	W2183	W2439	181	W2229	W2485	227	W2275	W2531
136	W2184	W2440	182	W2230	W2486	228	W2276	W2532
137	W2185	W2441	183	W2231	W2487	229	W2277	W2533
138	W2186	W2442	184	W2232	W2488	230	W2278	W2534
139	W2187	W2443	185	W2233	W2489	231	W2279	W2535
140	W2188	W2444	186	W2234	W2490	232	W2280	W2536
141	W2189	W2445	187	W2235	W2491	233	W2281	W2537
142	W2190	W2446	188	W2236	W2492	234	W2282	W2538
143	W2191	W2447	189	W2237	W2493	235	W2283	W2539
144	W2192	W2448	190	W2238	W2494	236	W2284	W2540
145	W2193	W2449	191	W2239	W2495	237	W2285	W2541
146	W2194	W2450	192	W2240	W2496	238	W2286	W2542
147	W2195	W2451	193	W2241	W2497	239	W2287	W2543
148	W2196	W2452	194	W2242	W2498	240	W2288	W2544
149	W2197	W2453	195	W2243	W2499	241	W2289	W2545
150	W2198	W2454	196	W2244	W2500	242	W2290	W2546
151	W2199	W2455	197	W2245	W2501	243	W2291	W2747
152	W2200	W2456	198	W2246	W2502	244	W2292	W2548
153	W2201	W2457	199	W2247	W2503	245	W2293	W2549
154	W2202	W2458	200	W2248	W2504	246	W2294	W2550
155	W2203	W2459	201	W2249	W2505	247	W2295	W2551
156	W2204	W2460	202	W2250	W2506	248	W2296	W2552
157	W2205	W2461	203	W2251	W2507	249	W2297	W2553
158	W2206	W2462	204	W2252	W2508	250	W2298	W2554
159	W2207	W2463	205	W2253	W2509	251	W2299	W2555
160	W2208	W2464	206	W2254	W2510	252	W2300	W2556
161	W2209	W2465	207	W2255	W2511	253	W2301	W2557
162	W2210	W2466	208	W2256	W2512	254	W2302	W2558
163	W2211	W2467	209	W2257	W2513	255	W2303	W2559
164	W2212	W2468	210	W2258	W2514			
165	W2213	W2469	211	W2259	W2515			

- NOTE**
- Channel: The inherent number of the timer and the counter (numbers that are equivalent to 000 of TC000).
 - Set Value (SV): The designated value for the timer (to turn On) and the counter (number of times On) to start operation.
 - Present Value (PV): Current processing value of the timer (elapsed time) and the counter (number of counts).

Address (register)

Address refers to the location of memory being used. It can refer to the external I/O module and internal memory.

An address is categorized into 1 bit, 16 bits (word), or 32 bits (double word).

Bit

A bit is the minimum module required for calculation. It can be either On (1) or Off (0).

Byte

A byte is made up of 8 bits. It can hold data values from 0 to 255. In base 16, or hexadecimal, a byte can be expressed as 0 to FF. You cannot have a value greater than 255 when using one byte.

Word

A word is made of 16 bits. It can hold data values from 0 to 65,535. In base 16 a word can be expressed as 0 to FFFF.

NX PLCs set R, M, K, F, and W areas into word areas and can be processed without any separate measures.

Double Word

A double word is made of 32 bits. It can hold data values from 0 to 4,294,967,295. In base 16, a double word can be expressed as 0 to FFFFFFFF. In the D32LT, a double word is made up of two consecutive word addresses as follows:

Double word address = Start word address + Next word address.

Example: When using W003,
W003 (double word address) = W003 (start word address) + W004 (next word address)

Scan Time

The CPU follows a procedure in which it 1) reads the inputs, 2) processes the ladder program, and 3) updates the outputs. It continually repeats this process. This 3-step process is called a "scan," and the time it takes to complete this process is the "scan time." In a typical PLC application, most of the scan time is used to process the program. When programming, keep in mind that the scan time will increase as you increase the number of inputs and outputs and/or the size of the program.

Edge

An edge is defined as the point when an input changes state. For example, a rising edge occurs during the very first scan after the input has changed from Off to On. A falling edge occurs after the input has changed from On to Off.

BCD (Binary Coded Decimal)

BCD is used to express a decimal digit (0 to 9) using 4 bits. Conversion of BCD values can be done in hexadecimal calculations.

Example: 59 (BCD) = 59 (HEX), 32 (BCD) = 32 (HEX)

Flash ROM

It refers to a ROM (EEPROM) that stores programs. Since its contents can be deleted periodically, it is frequently used for equipments that deals with programs such as a PLC.

How to use a register

- **R (Relay) register (Can be bit, word or double word)**
Indicates the external I/O register that directly connects to the general I/O module
- **M (Memory) register (Can be bit, word or double word)**
An internal bit memory address which supports the relay of logical operations. It is used as a word or double-word variable for general calculations and programs.

When the power of the PLC is turned off or the CPU has stopped, the register value is reset to 0.
- **W (Word) register (Can be bit, word or double word)**
Same usage as M registers. The value is preserved after the power is turned off, but can be cleared by program downloads or special command words.

NOTE Not used as a bit (register only for word use)

- **K (Keep) register (Can be bit, word or double word)**
Used for general calculation programs. The value is preserved after the power is turned off.
- **F (Flag) register (Only process bit)**
These bit registers provide special application specific functions to the programmer of the PLC. They are also used as system control bits, providing Run/Stop control of the PLC.
- **When a calculation or input value exceeds 65,535 (FFFF)**
Use a double word instruction that can store and calculate values over 65,535 in the K, M, R, and W registers. When a double word instruction is used, it can represent values up to 4,294,967,295 (2^{32}).
- **When you want to reload the contents or values that you worked today**
Use the K and W area. These are preserved unless specifically erased. The W area is erased by special instructions or program downloads.
- **When you need numerical expressions such as $A+B=C$, $34 \times 45=D$, $A1 > C1$.**
Use the R, M, W, and K area. If you use the R area, you can refer to and output calculated values in I/O modules.

- **For bit operations, such as setting, resetting, shifting, or rotating**
Use the M, K, and R area. You cannot perform bit operations in the W area.
- **When you want to refer to or modify the set value of the timer or counter.**
Refer to or modify W2048 to W2303 or SV0 to SV255.
- **When you want to refer to or modify the present value of the timer or counter.**
Refer to or modify the address area from W2304 to W2559 or from PV0 to PV255. The value holds true in STOP (PROG.) state in this area.
The present value (PV) of the counter is maintained even after the power is off.

Processor Operation Mode

What is the Processor operation mode?

The processor has an external RUN/REMOTE/PROG switch. The PLC performs a system check that determines the position of the switch. The switch position determines which operating mode the PLC is in. It can set to RUN, STOP, REMOTE, or ERROR mode.

RUN Mode (operating)

The PLC reads the external contact signals in Run mode and executes the user program stored in RAM. The external outputs are updated every scan according to program results.

STOP Mode

The user program is stopped and the external outputs are turned Off. In the Stop mode, you may correct, delete or transfer the program.(This is the only mode in which you can save a program in flash memory.)

PAUSE Mode

A user program is operated at every scan and the I/O and result value is maintained. This mode is used when checking and debugging a program at every scan. This mode is similar to the Stop mode, but it does not initialize data.

ERROR Mode

It occurs when the CPU module finds internal defects after running the self-diagnoses. Functions are not executed normally in this mode. When an error occurs, the CPU stops all programs and turns all output off. When an Error mode occurs, the user should check the error code and take appropriate measures. Then turn the power on or put the mode conversion switch in Prog and press the Initialize Key to clear the error.

Allowed Functions in Operation Modes

☼=On, ●=Flashing, ●=Off

Operation mode selector switch	Operation mode	LED status RUN LED PROG LED	Program change	Data change	Initialize switch is enabled	Mode at power off-on
RUN	RUN	☼ ●	Disallowed	Allowed	○	Run
	STOP	● ☼	Allowed	Allowed	○	Run
REMOTE	RUN	☼ ☼	Allowed	Allowed	○	Run
	PAUSE	● ☼	Allowed	Allowed	○	Pause
PROG	STOP	● ☼	Allowed	Allowed	○	Stop

When the PROG.LED is on, you can change the user program.

The INITIALIZE switch clears errors when the mode switch is set to PROG.

When the mode switch is set to REMOTE and power is switched from Off to On, the previous mode of operation is restored.

When debugging the user program, the mode switch should be set to REMOTE.

Processor Processing Procedure

Program processing procedure

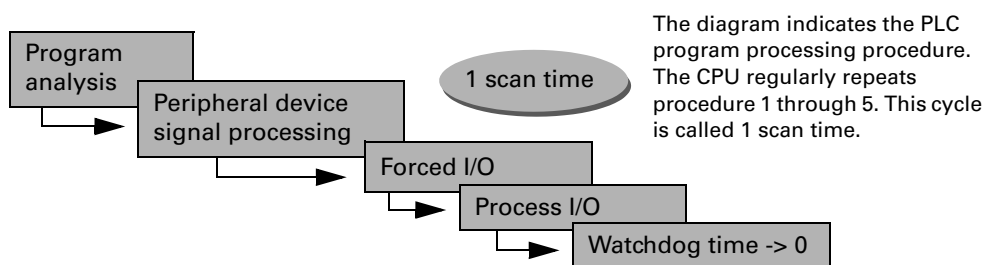

- Program analysis**
 Executes the program from its first step to its final step and stores the internal/external output in the working RAM.
- Peripheral device signal processing**
 Stores data from the communication module or peripheral device to the internal memory.
- Forced I/O processing**
 Turns on/off forced I/O bits, if any.
- I/O processing**
 Preserves the On/Off state of the external I/O and uses it as an input in the next scan. (For accurate processing, input should continue for more than 1 scan time.)
 The processed program outputs are sent from internal memory to the external memory.

- **Watchdog time initialization**

The watchdog elapsed time value is set to 0. (This value is the watchdog calculation point until the next scan.)

The following illustration shows the difference between the relay board and PLC sequence processing. The relay carries out all sequences simultaneously while the PLC processes sequentially throughout the program.

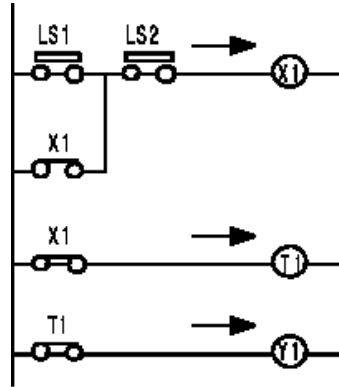

Processing of relay sequence
(Parallel process)

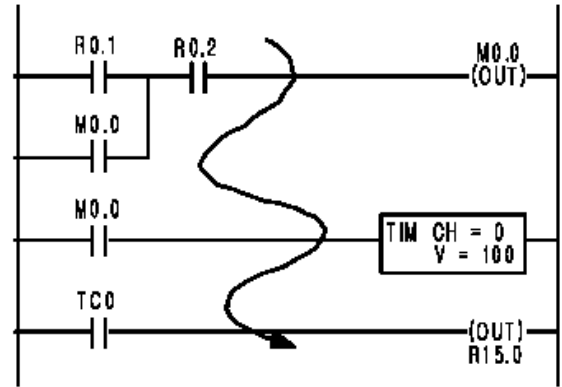

Processing of PLC program
(Serial process)

Installation and Wiring

Installation

Installation space and environment

External dimensions (mm)

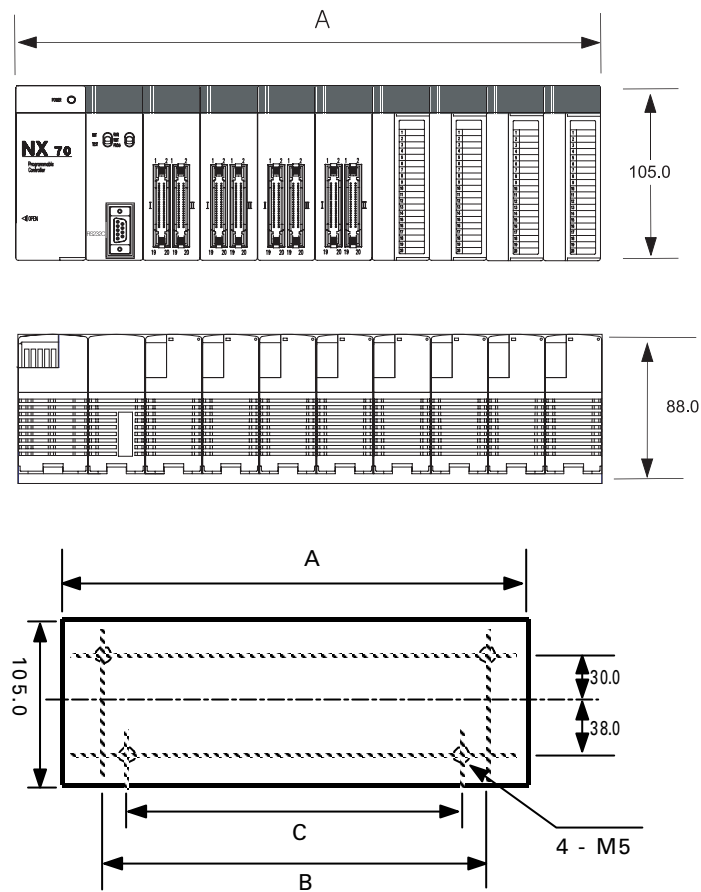

Unit: mm

Type of backplane	Catalog number	Size A	Size B	Size C
2-slot type	NX70-BASE02	149.5	129.5	115.5
3-slot type	NX70-BASE03	185.0	165.0	151.0
5-slot type	NX70-BASE05	256.0	236.0	222.0
6-slot type	NX70-BASE06	291.5	271.5	257.5
8-slot type	NX70-BASE08	362.5	342.5	328.5
10-slot type	NX70-BASE10	398.0	378.0	364.0
12-slot type	NX70-BASE12	433.5	413.5	399.5

Installation location

Be sure to maintain a sufficient distance from wiring ducts, and other machines below and above the module for proper ventilation.

Do not install the modules stacked up or horizontally. Doing so will prevent proper cooling of the module and cause overheating inside the PLC (programmable controller).

Do not install the module above devices which generate heat such as heaters, transistors or large scale resistors.

In order to eliminate any effects from noise emission, power wires and electromagnetic devices should be kept at least 100 mm away from the surfaces of the module. When installing the module behind the doors of the operation panel, be especially careful to maintain these distances.

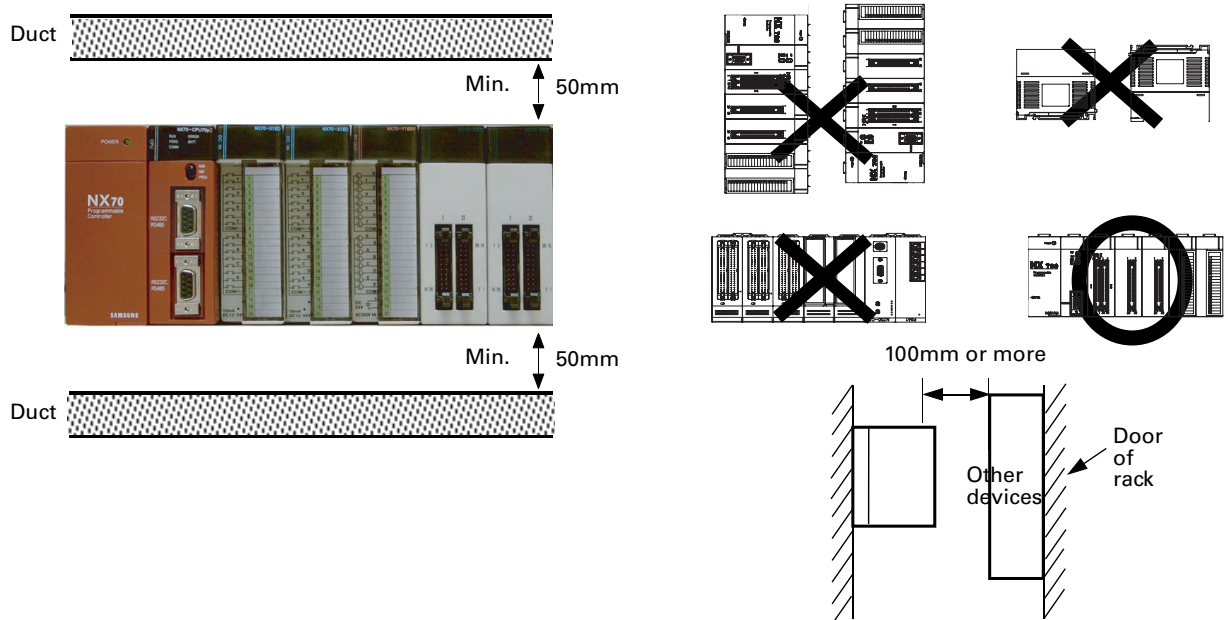

Space for programming tool connection

Leave a space of at least 180 mm from the mounting surface for programming tool connections and wiring.

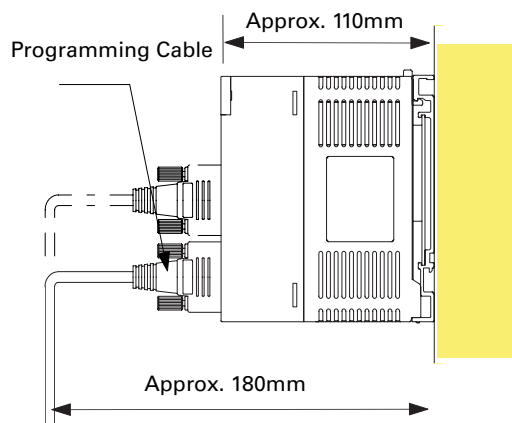

Avoid installing the module in the following conditions

- Ambient temperature outside the range of 0 to 55 ° C
- Ambient humidity outside the range of 30 to 85% RH
- Sudden temperature changes causing condensation
- Inflammable or corrosive gases
- Excessive airborne dust, metal particles, salinity
- Benzene, thinner, alcohol, other organic solvents or strong alkaline solutions such as ammonia or caustic soda
- Excessive vibration or shock
- Direct sunlight
- Location near high-tension wires, high-voltage devices, power cables, power devices, or other devices with generate large power surges or electronic fields when starting and stopping (esp. if within 100 mm)

Power Supply Module Wiring

Power supply module wiring

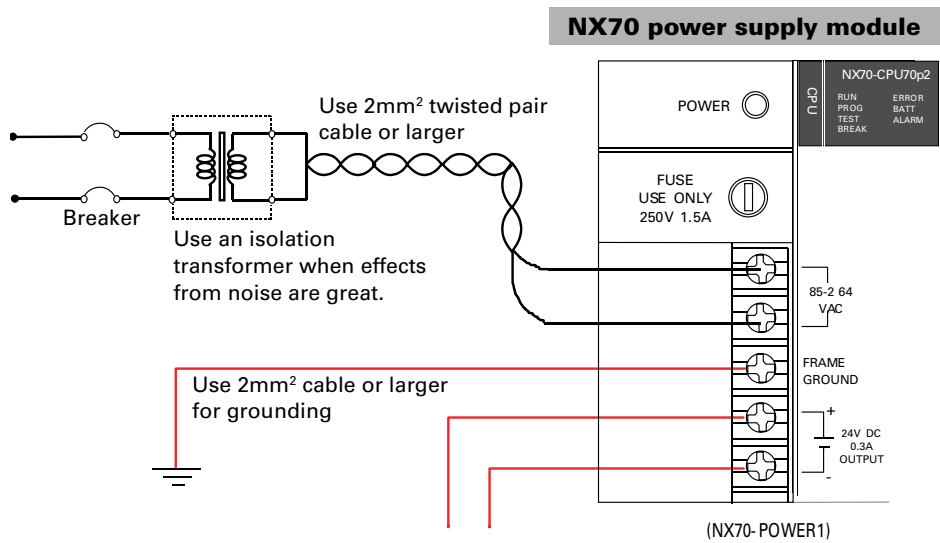

The power supply voltage connected to the power supply module must be within allowable limits.

Catalog number	Rated input voltage	Allowable voltage Range
NX70-POWER1 NX70-POWER2	110 to 220V ac	85 to 264V ac

Terminal for the power supply module

- The terminal screw M3.5 is recommended.
- The compressed connection terminal is recommended for the wiring.

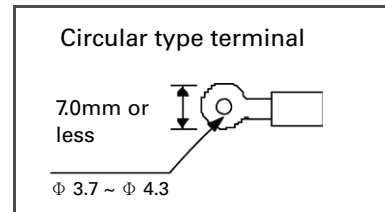
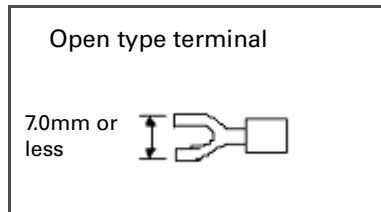

Use 2mm² twisted pair cable or larger

- Use power supply wire that is thicker than 2mm² to minimize voltage drops.
- Use twisted pair cable to minimize noise effects.

Proper compressed connection terminal

- Circular type terminal (O type Lug)
- Circular type terminal with insulation resistance
- Open type terminal (Y type Lug)

Power supply system

Use separate wiring systems for the PLC module, I/O module, and power supply module as shown in the following diagram.

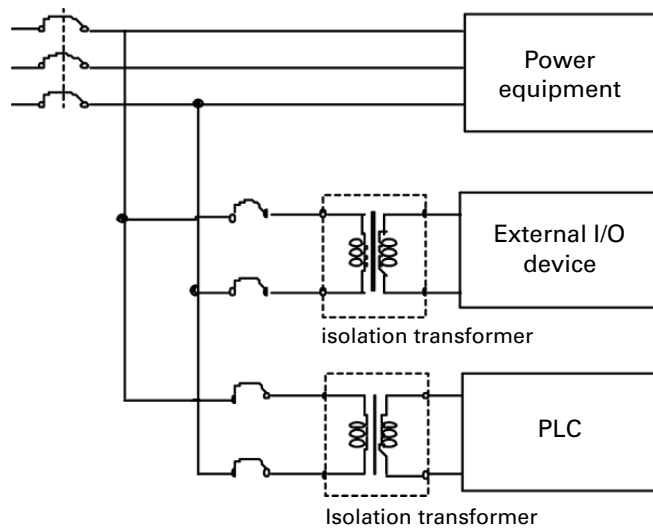

Use isolation transformer for noisy environments

- Use a low noise power supply.
- Use an isolation transformer to reduce the noise as illustrated above.

Grounding

Ground the PLC for noisy environments

- Connected to the metal part of backplane, the frame ground terminal is connected to a solid earth ground.
- Use ground wires with a minimum of 2mm² and the triple grounding connection which has a resistance of less than 100 Ω
- The point of grounding should be as close to the PLC as possible and the ground wire should be as short as possible.
- If two devices share a single ground point, it may produce an adverse effect. Always use an exclusive ground for each device.

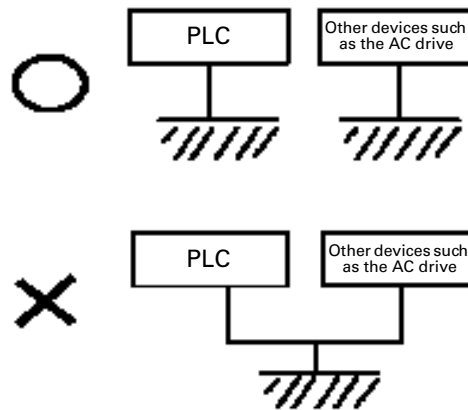

Input and Output Wiring

Input wiring

Check points

- Simultaneous ON points can be limited depending on the particular module type. Check the specifications of each input module, and be cautious when the ambient temperature is high.
- The input device connection methods are shown in the following graphics for the various types of input devices.

Connection methods for photoelectric sensor and proximity sensor

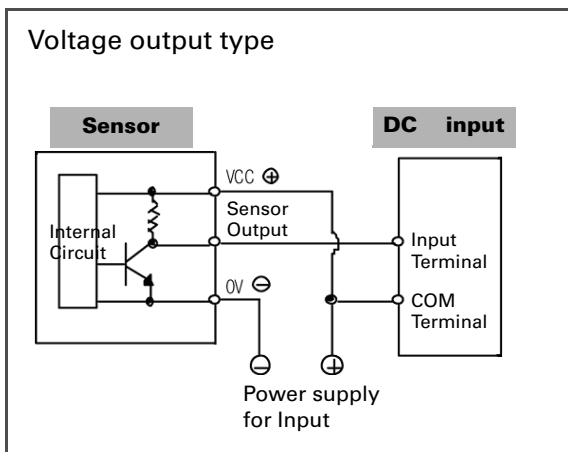
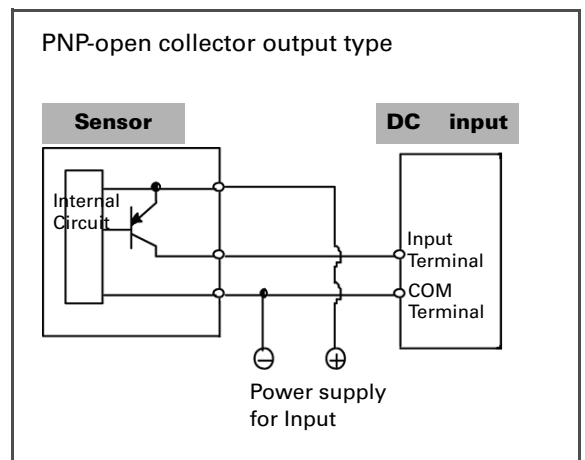
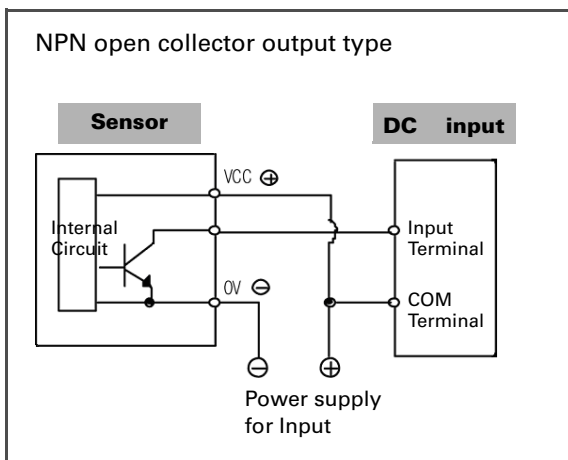
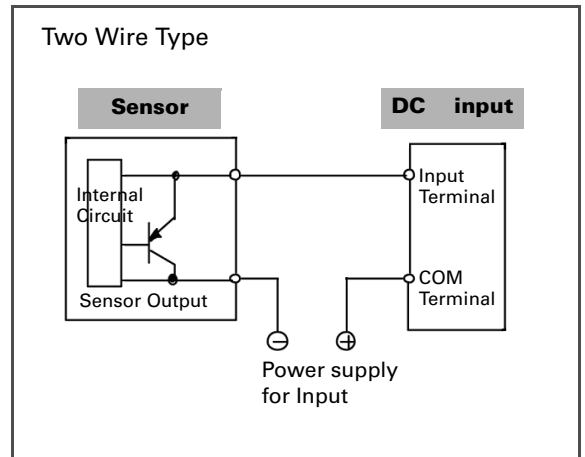
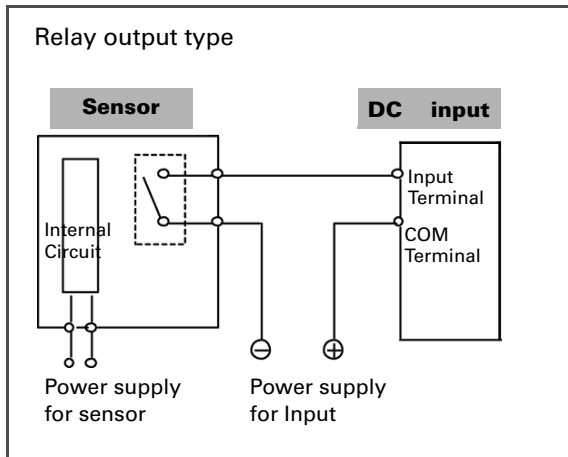

Connection to AC input module

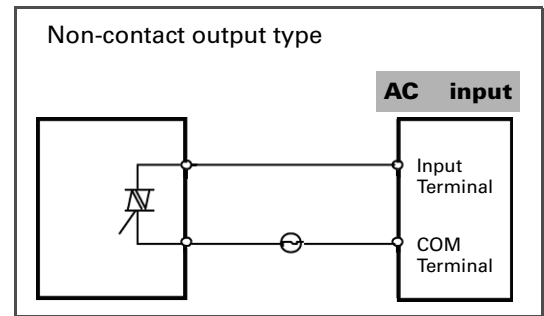
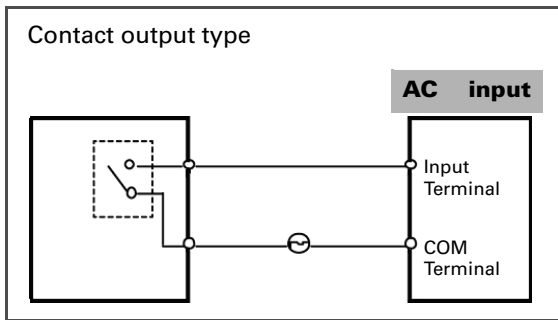

Precaution when using a LED reed switch

With a LED is connected to an input contact such as LED-equipped reed switch, make sure that the voltage value applied to the input terminal of PLC is greater than on voltage value. In particular, take care when connecting several switches in a series.

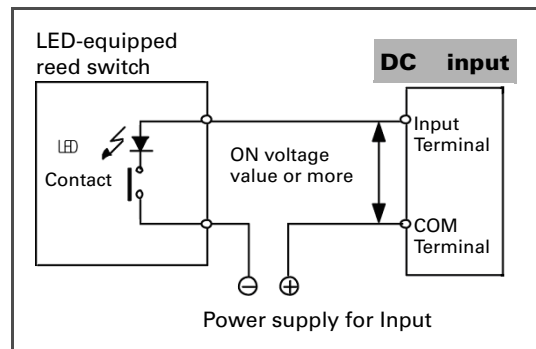

Precautions when using a 2-wire sensor

If the input of the PLC is not turned off because of current leakage from the two-wire type sensor, the connection of a bleeder resistor is recommended, as shown below.

12 to 24V dc type input module
(Off voltage 2.5V, input impedance 3 k Ω)

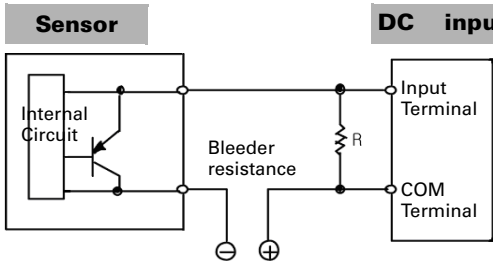

I: Leakage current of the sensor (mA)
R: Bleeder resistance (k Ω)

The off voltage of the input is 2.5V, select an R value so that the voltage between the COM terminal and the input terminal will be less than 2.5V.
The input impedance is 3 k Ω

$$1 \times \frac{3R}{3 + R} \leq 2.5, \quad R \leq \frac{7.5}{31 - 2.5} \text{ (k}\Omega\text{)}$$

The wattage W of the resistor is:

$$W = \frac{R}{(\text{Power voltage})}$$

In the actual selection, use a value that is 3 to 5 times the value of W.

Precautions when using a LED LIMIT switch

With the LED-equipped LIMIT switch, if the input of the PLC is not turned off or if the LED of the LIMIT switch is kept on because of the leakage current, the connection of a bleeder resistor is recommended, as shown below.

For 12 to 24V dc input module
(Off voltage 2.5V, input impedance 3 kΩ)

LED-equipped limit switch

DC input

Internal Circuit

Bleeder resistor

Input Terminal

COM Terminal

r: Internal resistor of limit switch (kΩ)
R: Bleeder resistor (kΩ)

The off voltage of the input is 2.5V, therefore when the power supply voltage is 24V, select R so that the current will be greater than

$$I = \frac{24 - 2.5}{r}$$

The resistance R of the bleeder resistor, and the wattage of W of the resistor are as shown below.
In the actual selection, use a value that is 3 to 5 times the value of W.

$$R \leq \frac{7.5}{31 - 2.5} \text{ (k}\Omega\text{)} \quad W \leq \frac{(\text{Power voltage})^2}{R}$$

Output wiring

Check points

- Simultaneous ON points or load current can be limited depending on the particular module type. Check the specifications of each output module, and be cautious when the ambient temperature is high.
- Use a protection circuit when connecting inductive loads and capacity loads.
- Use the output module only within the specified ranges of operation because of the current limitations per common.

Protective circuits for inductive loads

- When connecting an inductive load, a protective circuit should be connected in parallel with the load.
- When connecting the DC type inductive loads and relay type output module, be sure to connect a diode for protective circuit across the ends of the load. This will affect the life of the relay.

When using an AC type inductive load (Relay output type)

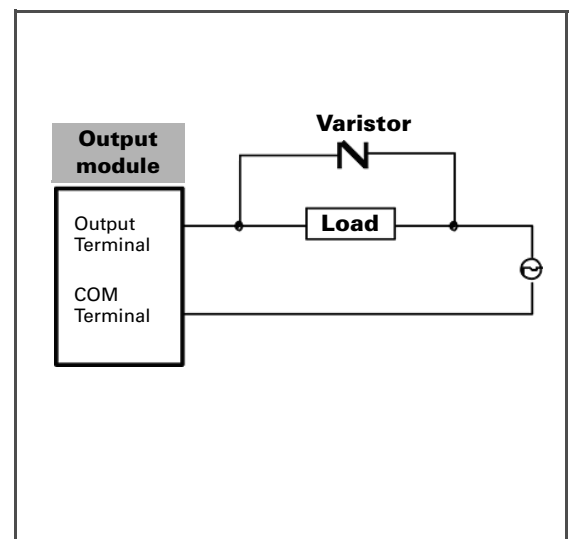
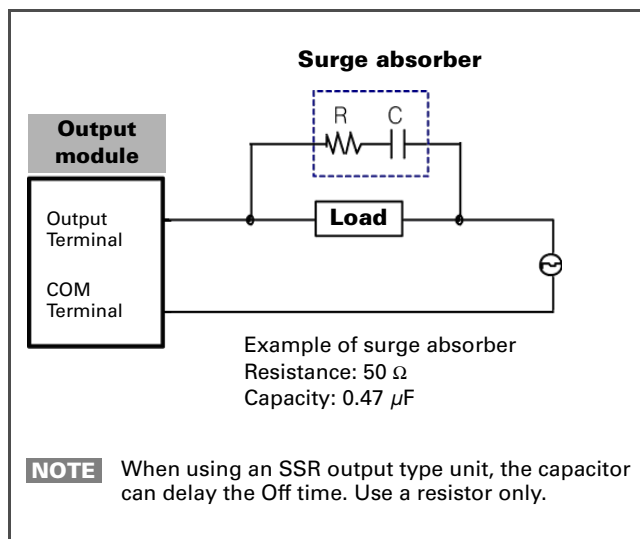

When using a DC type inductive load

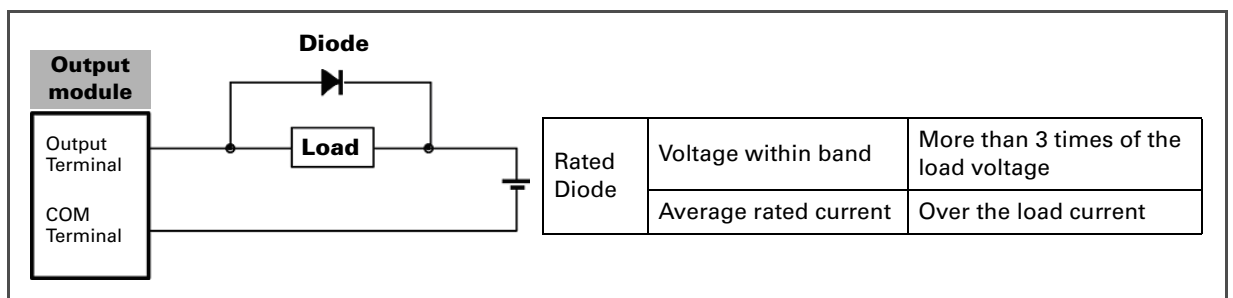

Connection of capacitive loads

When connecting the loads with large inrush currents, be sure to connect a protective circuit.

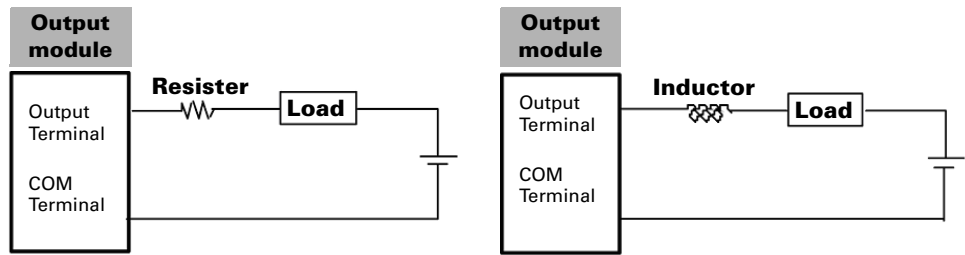

Precautions for overload

The fuse within the module is provided to prevent damage in case of a short circuit on the output.

Even if the module with the fuse cannot protect the overload for each element, it is recommended to attach an external fuse for each output point.

However, the module fuse is not designed to protect the device of the output module in case of short circuits.

Precautions for leakage current

When using a SSR output, the leakage current in the SSR output may cause a load not to turn Off. To prevent this problem, connect the resistance in parallel with the load.

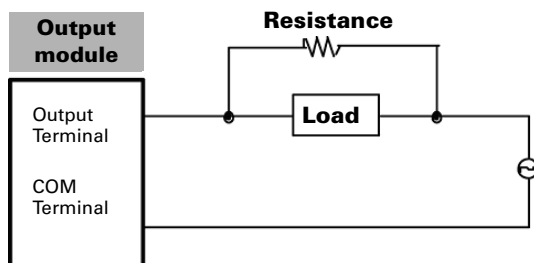

I/O module installation precautions

I/O and power cable

- Separate the wiring of the I/O cable and the power cable as far as possible. Do not put the two cables through the same duct.
- Leave 100 mm or more between I/O wiring, power cable or high voltage cable.

Module cover

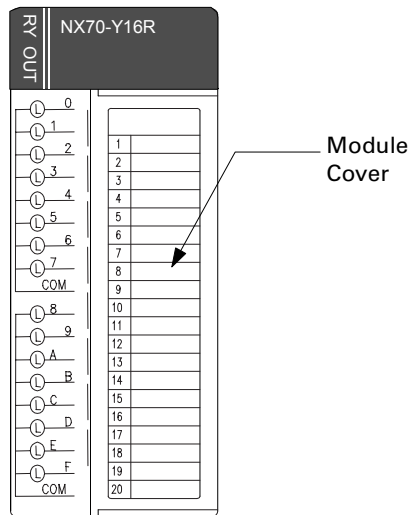

Terminal Block Type Module Wiring

Compressed terminal, M3.0

The terminal base for the NX70 PLC I/O modules (Terminal Type) uses M3.0 terminal screw. Use the following compressed terminals for terminal wiring.

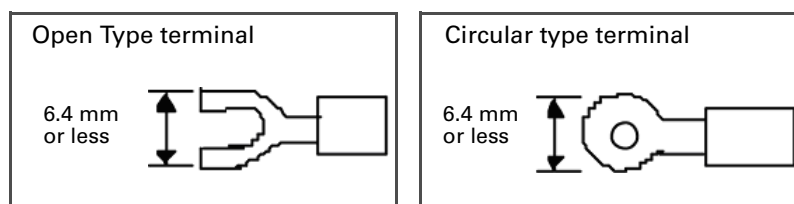

Connector Type Module Wiring

Wiring instructions

Wiring instructions

For the 32-point input module (NX70-X32D, NX70-X32D1) of the NX70 PLC and the 32-point output module (NX70-Y32T, NX70-Y32P), use a 20-pin MIL type connector. To connect with other devices;

- Use each pin for each socket
- Use flat cable for harnessing
(Available for purchase)

Pin type connection

This is used to connect to each socket using an individual pin. The wiring will be described on the next page.

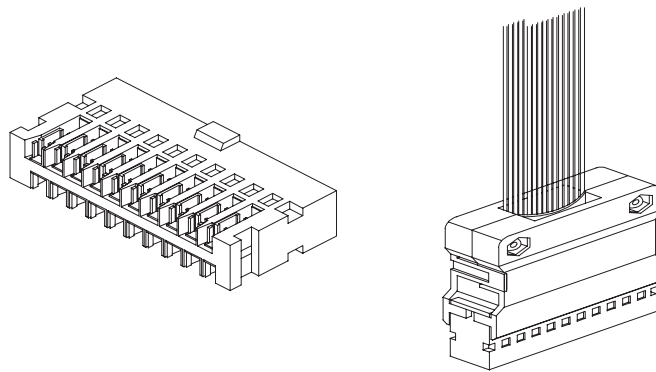

Product name	Catalog number	Specification
I/O connector assembly (Pin type)	NX-PIN 20	20 pins 1) Pin: 20 ea 2) Connector hood 3) Sockets

Product code/specification	
32-point input module	NX70-X32D (DC 32 input points, 12 to 24V) NX70-X32D1 (DC 32 input points, 24V)
32-point output module	NX70-Y32T (TR 32 output points, NPN) NX70-Y32P (TR 32 output points, PNP)

Harness connection (using flat cable connector)

The harness cable consists of a 20-pin flat cable connector and 20 separate compressed terminals at the end. The cable is 1.5 m in length. Connect directly to the module to use.

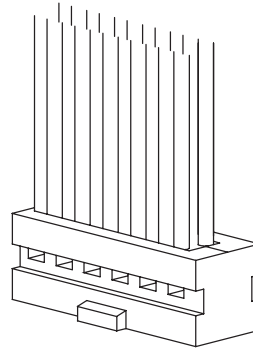

Product name	Catalog number	Specification
Cable assembly	NX70_CBLDC	DC 32 input points, Connector harness cable 1.5 m
	NX70_CBLTR	TR 32 output points Connector harness cable 1.5 m

Product code/specification	
32-point input module	NX70-X32D (DC 32 input points, 12 to 24V) NX70-X32D1 (DC 32 input points, 24V)
32-point output module	NX70-Y32T (TR 32 output point, NPN) NX70-Y32P (TR 32 output point, PNP)

References (product codes)

Product name	Catalog number
Input module	NX70-X16D
	NX70-X16D1
	NX70-X32D
	NX70-X32D1
	NX70-X16A110
	NX70-X16A220
Output module	NX70-Y8R
	NX70-Y16R
	NX70-Y16RV
	NX70-Y16T
	NX70-Y32T
	NX70-Y32P
	NX70-Y16SSR
Mixed I/O module	NX70-XY16
	NX70-XY32

How to use pressure socket for pin-type connection

The wire end can be directly press-fitted without removing the wire's insulation, saving labor.

Procedure

Bend the contact back from the carrier, and set it in the pressure connection tool.

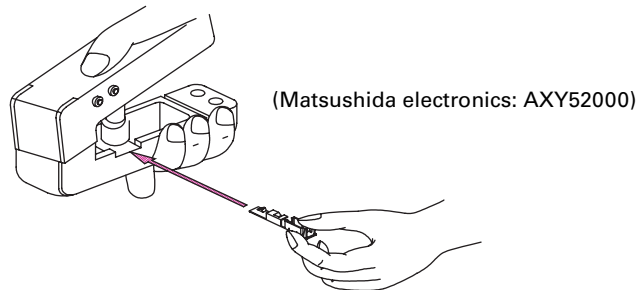

Insert the wire without removing its insulation until it stops, and lightly grip the tool.

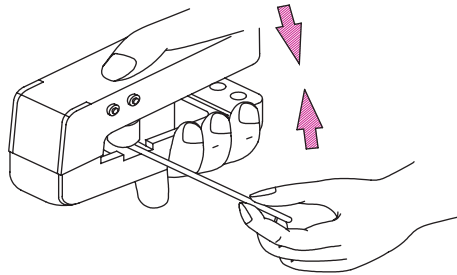

After press-fitting the wire, insert it into the housing.

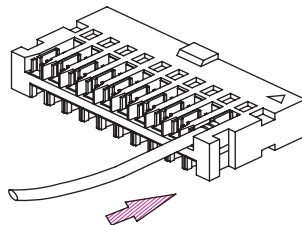

→ Contact control pins for wiring errors

With wiring or cable pressure errors, redo it using the contact controlling pins connected with the devices.

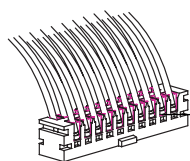
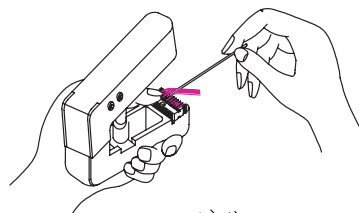

Press the housing against the pressing tools until this part touches the pins for removing contacts.

Flat cable connector connection

Precautions when using a flat cable connector

When using a flat cable for wiring field devices, pay careful attention to the I/O number associated with the given cable number.

Connecting 32-point connector type

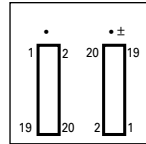
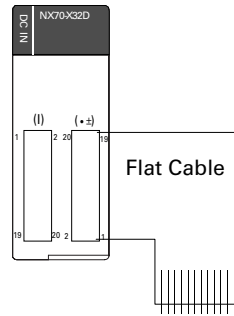

Product name	Catalog number	Specification
Flat cable (1.5m)	NX70_CBLDC	For DC 32 input points (NX70-X32D) (NX70-X32D1)
	NX70_CBLTR	For TR 32 output points (NX70-YX32T) (NX70-YX32P)

I/O address cross-reference table for flat cable number (32 points)

Connector (I)			Connector (II)		
I/O point	NX70-X32D NX70-X32D1	NX70-Y32T NX70-Y32P	I/O point	NX70-X32D NX70-X32D1	NX70-Y32T NX70-Y32P
I 1	X 0	Y 0	II 20	COM2	COM
I 2	X 1	Y 1	II 19	COM2	COM
I 3	X 2	Y 2	II 18	COM1	+
I 4	X 3	Y 3	II 17	COM1	+
I 5	X 4	Y 4	II 16	X1F	Y1F
I 6	X 5	Y 5	II 15	X1E	Y1E
I 7	X 6	Y 6	II 14	X1D	Y1D
I 8	X 7	Y 7	II 13	X1C	Y1C
I 9	X 8	Y 8	II 12	X1B	Y1B
I 10	X 9	Y 9	II 11	X1A	Y1A
I 11	X A	Y A	II 10	X19	Y19
I 12	X B	Y B	II 9	X18	Y18
I 13	X C	Y C	II 8	X17	Y17
I 14	X D	Y D	II 7	X16	Y16
I 15	X E	Y E	II 6	X15	Y15
I 16	X F	Y F	II 5	X14	Y14
I 17	COM1	+	II 4	X13	Y13
I 18	COM1	+	II 3	X12	Y12
I 19	COM2	COM	II 2	X11	Y11
I 20	COM2	COM	II 1	X10	Y10

The (I) and (II) connectors are positioned in opposite directions. Please use caution prior to connecting.

Safety Measures

Precautions regarding system design

In certain applications, malfunction may occur for the following reasons:

- The timing difference between opening and closing of the PLC power supply, the I/O modules and power equipment
- An operation time lag when a momentary power failure occurs
- Abnormality in the PLC, external power supply, or other devices

In order to prevent a malfunction resulting in system shutdown choose the adequate safety measures listed in the following:

Interlock circuits on the outside of PLC

When a motor clockwise/counter-clockwise operation is controlled, provide an interlock circuit that prevents clockwise and counter-clockwise signals from inputting into the motor at the same time.

Emergency stop circuits on the outside of PLC

Install the emergency stop circuits outside the PLC to stop the power supply of the output device.

Start PLC after other devices (Start up sequence)

The PLC should be operated after all of the I/O devices and the power equipments are energized.

- Switch to RUN mode after the start of PLC.
- Use a timer circuit to delay the start of PLC.

Watchdog timer

The watchdog timer is a program error and hardware error detection timer. It goes On when the scan time exceeds 640 ms.

When the watchdog timer is activated, at the same time the ALARM LED lights, the ALARM contacts on the power supply module turn to On, all output modules are turned Off and the module is put in halted state. (The system is in a non-processing state that includes communications with programming tools as well.)

NX70 Processor Module Communications Specifications

Connection specification	RS485	RS232C	Remarks
Transfer distance (Max)	1.2 Km	15 m	
Transmission speed	38,400, 19,200, 9,600, 4,800 bps		DIP switch setting
Protocol	Half duplex asynchronous polling		
Parity	No parity		
Stop bit	1 stop bit		
Cable type	Twisted pair cable		Use shield cable

NOTE RS232C/RS485 cable wiring diagram: NX_CBLCPU2(2m), NX_CBLCPU5(5m)

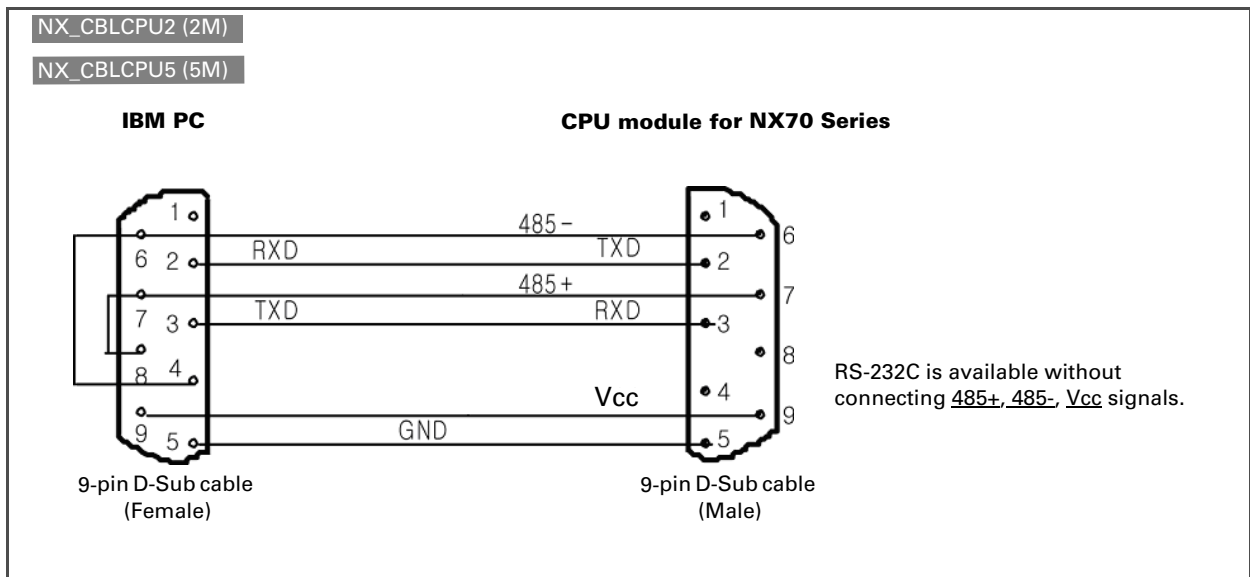

Reference (25 pin to 9 pin) wiring diagram

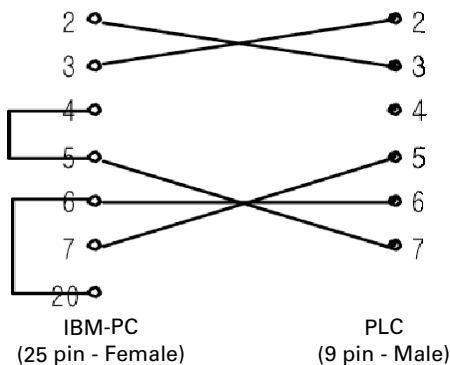

EEPROM Backup (for NX70-CPU70p1, NX70-CPU70p2)

What's EEPROM backup?

EEPROM (Electric Erase Programmable Read Only Memory) can retain the data when the power is turned off, and erase or record data when the power is turned on. This function allows you to retain the PLC program when the power is turned off. And it also erases an existing program and records a new one when correcting or storing a program after turning on the power.

Applicable models

The types of EEPROM can be defined by its characteristics. The CPUs for OE MAX NX70 (NX70-CPU70p1 and NX70-CPU70p2) PLC use the flash memory.

This function is widely used since it is easy to use, store, and transfer data, and is built in the NX70 PLC (NX70-CPU70p2).

EEPROM uses 29EE512 and has a minimum of 3000 times to write to flash memory. It should be noted that the memory is to be changed when exceeding the use of over 3,000 times.

Procedure

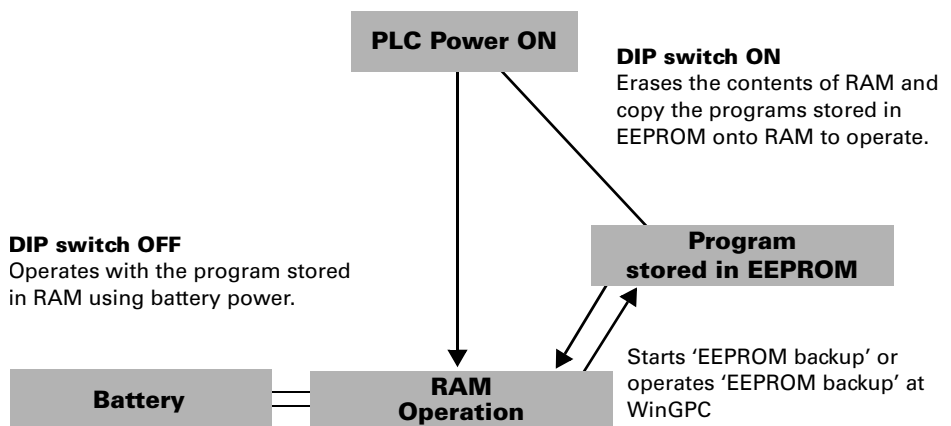

Backup using WinGPC

How to backup using WinGPC

Connect Online.

Save the completed program onto the PLC (Download: WinGPC => PLC).

Select the 'EEPROM Backup (E)' in the 'Online' menu.

Test Run and Troubleshooting

Test Run Precautions

Before installing the I/O wiring of the PLC and supplying power, check the following items.

Check the connection of the power cable	<table border="1"> <thead> <tr> <th>Item</th> <th>What to check</th> </tr> </thead> <tbody> <tr> <td>The connection of the power cable and the I/O cables</td> <td> <ul style="list-style-type: none"> • Check if the wiring is secured. • Check if the terminal screws are tightened. • Check if the parts of connectors are properly joined. • Check if the I/O modules are firmly fixed. • Check if the power cable is securely connected. • Check if the cable size is correct. </td> </tr> <tr> <td>Grounding</td> <td> <ul style="list-style-type: none"> • Check if the grounding is triple grounded and separate from other device grounds. </td> </tr> <tr> <td>Battery</td> <td> <ul style="list-style-type: none"> • Check if the battery is installed into holder on the CPU module. • Check if the battery connector is connected to the CPU board </td> </tr> <tr> <td>Emergency stop circuit</td> <td> <ul style="list-style-type: none"> • Check if the emergency stop circuit for problems external to the PLC is wired accurately, and will immediately disconnect power on demand. </td> </tr> <tr> <td>Power source</td> <td> <ul style="list-style-type: none"> • Check if the power and voltage sources are within specifications. <ul style="list-style-type: none"> - For 110V ac (90 to 132V ac) - For 220V ac (180 to 264V ac) • Check if the power to the AC input module is within specifications. </td> </tr> </tbody> </table>	Item	What to check	The connection of the power cable and the I/O cables	<ul style="list-style-type: none"> • Check if the wiring is secured. • Check if the terminal screws are tightened. • Check if the parts of connectors are properly joined. • Check if the I/O modules are firmly fixed. • Check if the power cable is securely connected. • Check if the cable size is correct. 	Grounding	<ul style="list-style-type: none"> • Check if the grounding is triple grounded and separate from other device grounds. 	Battery	<ul style="list-style-type: none"> • Check if the battery is installed into holder on the CPU module. • Check if the battery connector is connected to the CPU board 	Emergency stop circuit	<ul style="list-style-type: none"> • Check if the emergency stop circuit for problems external to the PLC is wired accurately, and will immediately disconnect power on demand. 	Power source	<ul style="list-style-type: none"> • Check if the power and voltage sources are within specifications. <ul style="list-style-type: none"> - For 110V ac (90 to 132V ac) - For 220V ac (180 to 264V ac) • Check if the power to the AC input module is within specifications.
Item		What to check											
The connection of the power cable and the I/O cables		<ul style="list-style-type: none"> • Check if the wiring is secured. • Check if the terminal screws are tightened. • Check if the parts of connectors are properly joined. • Check if the I/O modules are firmly fixed. • Check if the power cable is securely connected. • Check if the cable size is correct. 											
Grounding		<ul style="list-style-type: none"> • Check if the grounding is triple grounded and separate from other device grounds. 											
Battery		<ul style="list-style-type: none"> • Check if the battery is installed into holder on the CPU module. • Check if the battery connector is connected to the CPU board 											
Emergency stop circuit		<ul style="list-style-type: none"> • Check if the emergency stop circuit for problems external to the PLC is wired accurately, and will immediately disconnect power on demand. 											
Power source	<ul style="list-style-type: none"> • Check if the power and voltage sources are within specifications. <ul style="list-style-type: none"> - For 110V ac (90 to 132V ac) - For 220V ac (180 to 264V ac) • Check if the power to the AC input module is within specifications. 												
↓													
Check the connection of the I/O cable													
↓													
Check the grounding													
↓													
Check the battery													
↓													
Check the emergency stop circuit													
↓													
Supply power													

Test Run Procedure

When the PLC has been installed and wired, begin test run in the following order.

	Item	What to check/do
Supply power		
↓		
Check the battery	Supply power	<ul style="list-style-type: none"> • Check if the input voltage of the power supply module is within specifications. • Check if the power voltage for the I/O modules is within specifications. • Connect WinGPC to the CPU module. (Set the CPU module to the PROG mode.) • Turn on the power source. • Check the LED display of the power supply module.
↓		
Check I/O wiring	Initialize memory	<ul style="list-style-type: none"> • Initialize the PLC using WinGPC. (This clears the program on the PLC.)
↓		
Programming	Check I/O wiring	<ul style="list-style-type: none"> • Check the LED of the input modules and use the monitor function of WinGPC or HHP after test run the input device. • Check the wiring of the output by turning the output On/Off using the monitor mode of WinGPC. (set CPU module to Run mode.)
↓		
Test run	Programming	<ul style="list-style-type: none"> • Input the program instructions using WinGPC. • Download the program from WinGPC into the CPU module, if any.
↓		
Correct program	Test run	<ul style="list-style-type: none"> • Set the mode switch of the CPU module to run. • Check if the Run LED is illuminated. • Check the sequence operation.
↓		
Store program	Correct program	<ul style="list-style-type: none"> • Check and correct any program errors.
↓		
End	Store program	<ul style="list-style-type: none"> • Store the program onto a floppy disk or similar storage device such as HDD. • Print the program (ladder, mnemonic) and store it in a secure place.
	NOTE It is recommended to record the PLC types, program capacity, name of installation, and date for the recorded program.	

Test Run Flow Charts

System check flow chart

When you encounter problems during startup or test run, first of all, figure out the problems thoroughly. Check if the problems can be reproduced, and analyze the relevance to other devices. Then refer to the system check flow chart.

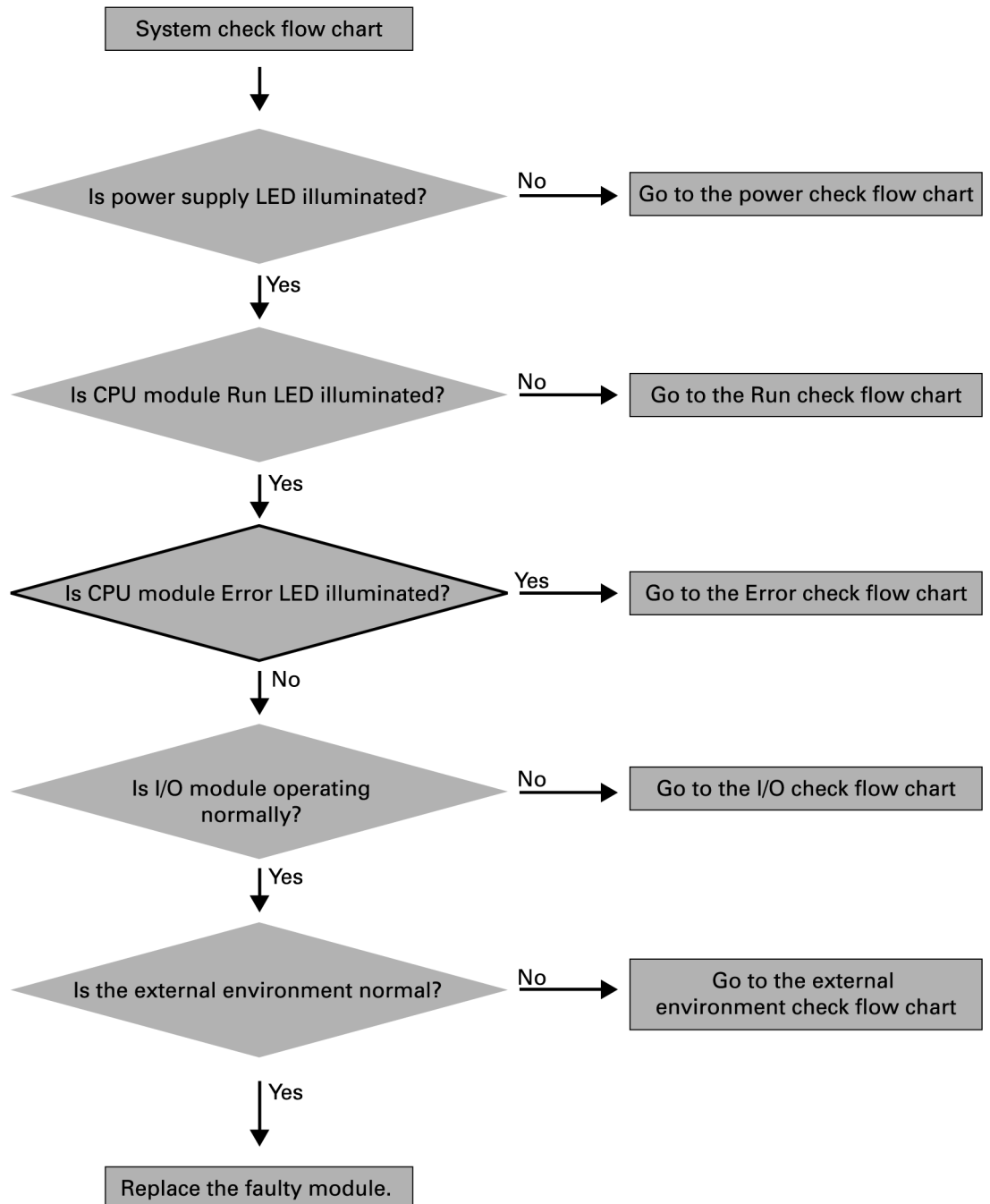

Power check flow chart

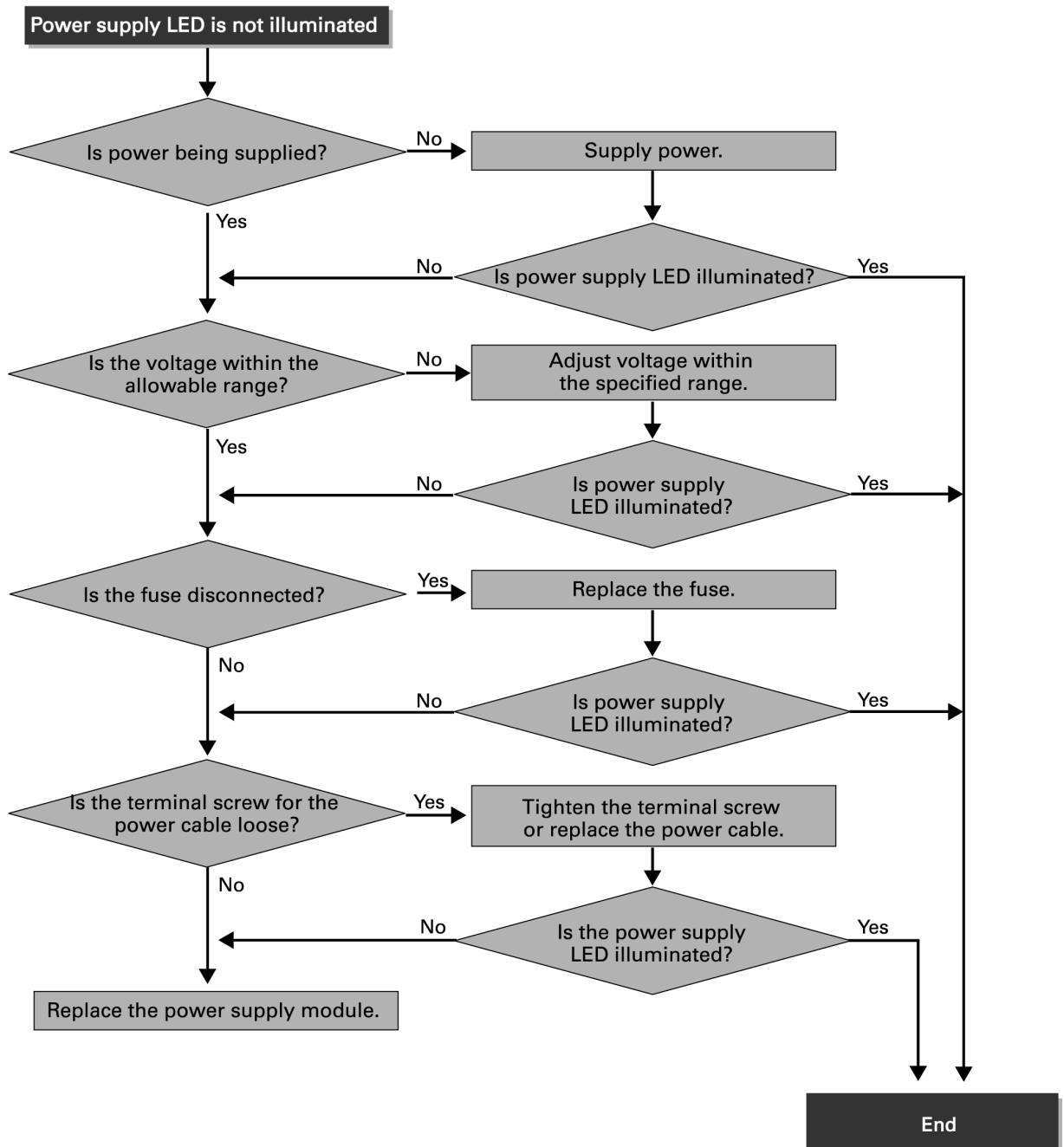

Run check flow chart

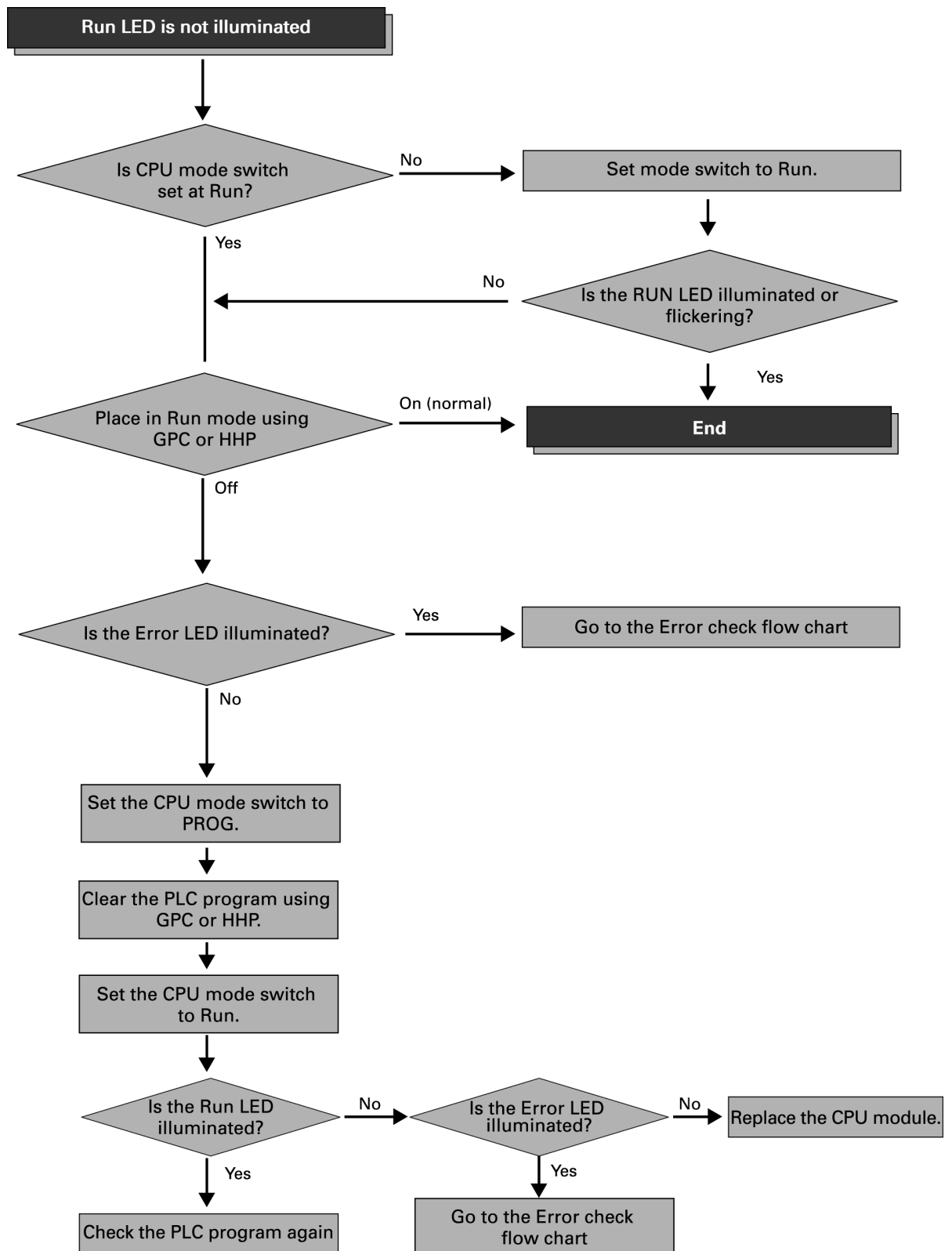

Error check flow chart

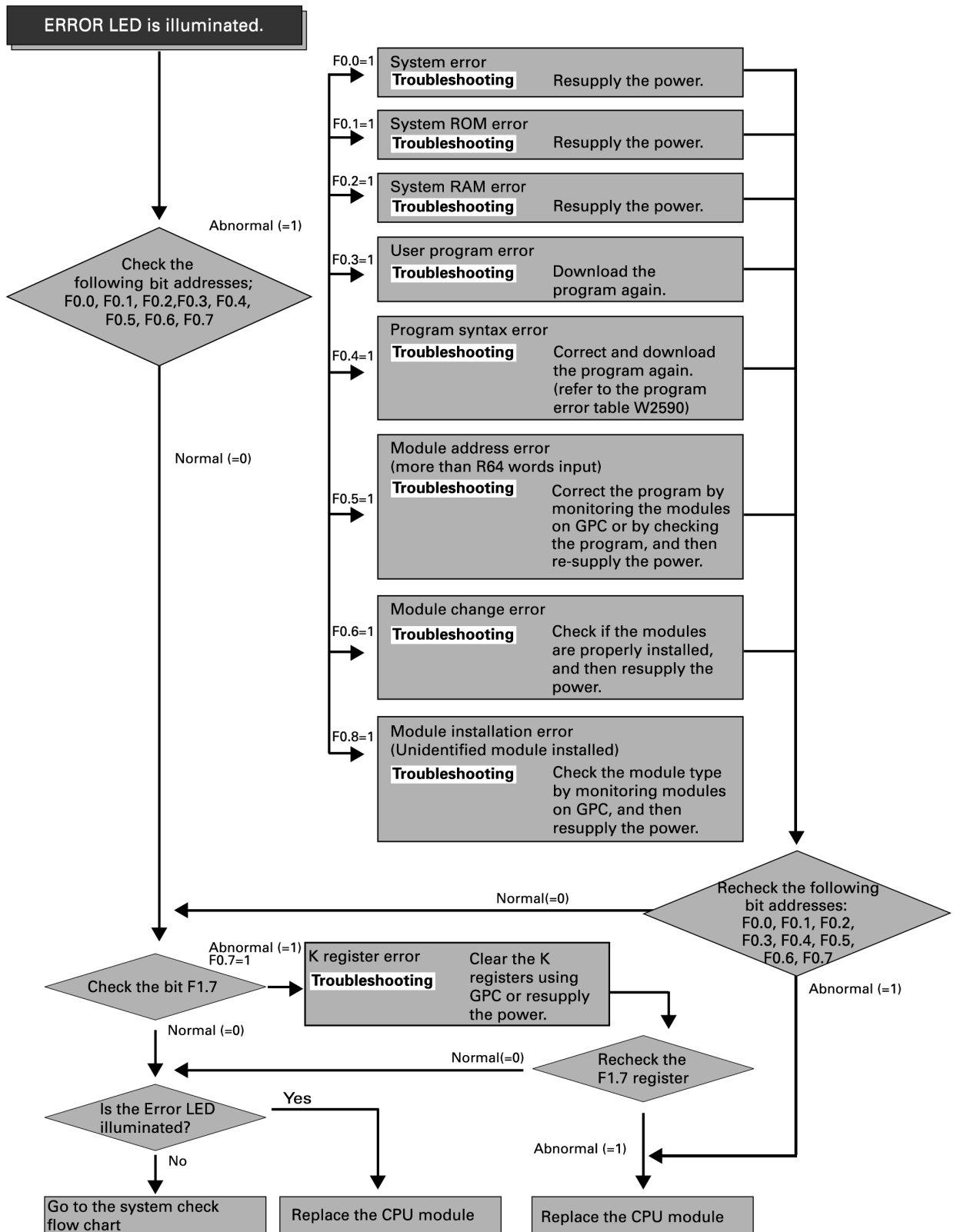

I/O check flow chart

This page presents an example of a troubleshooting procedure based on the right circuit.

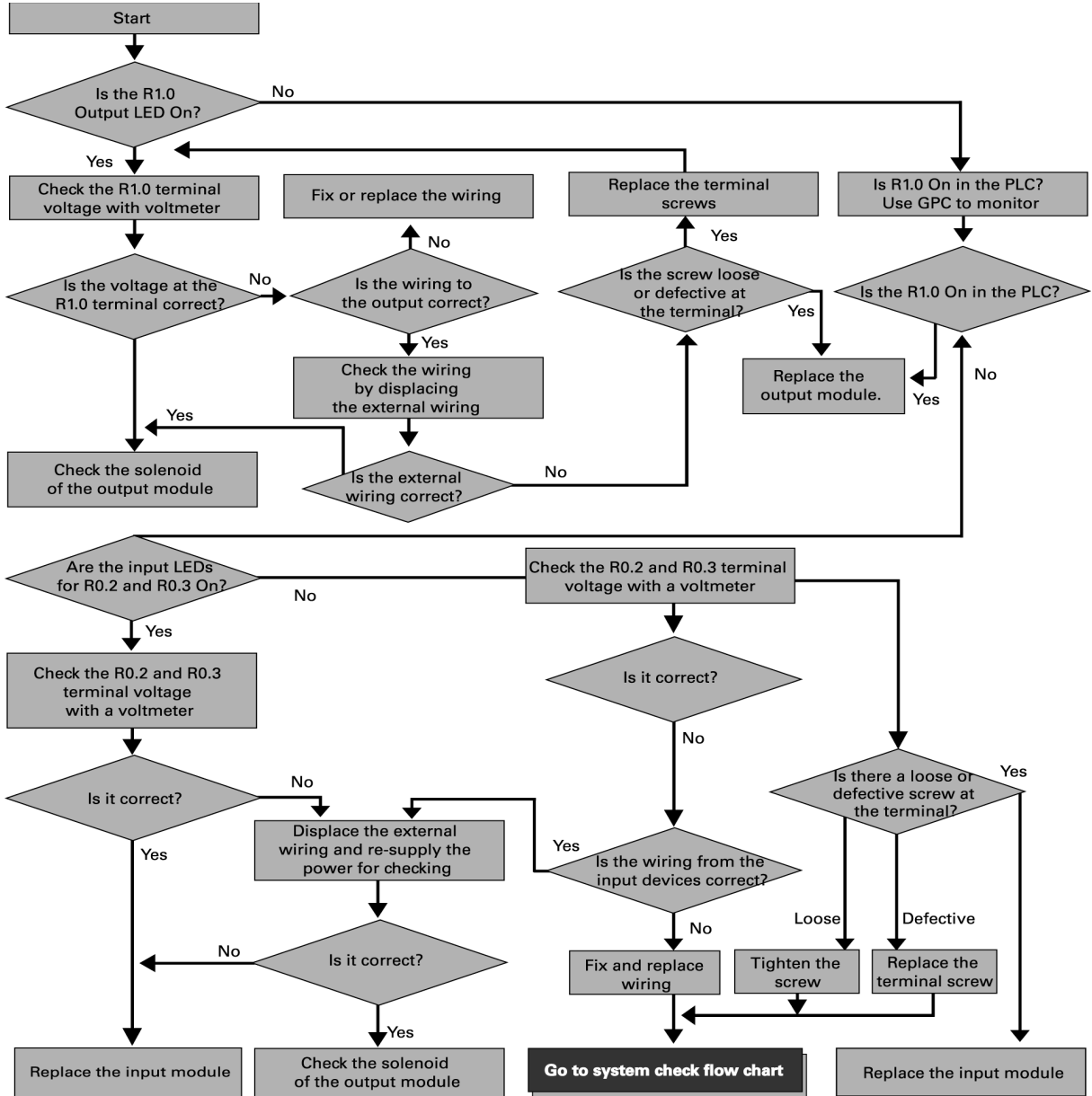
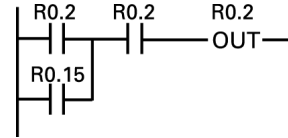

External environment check flow chart

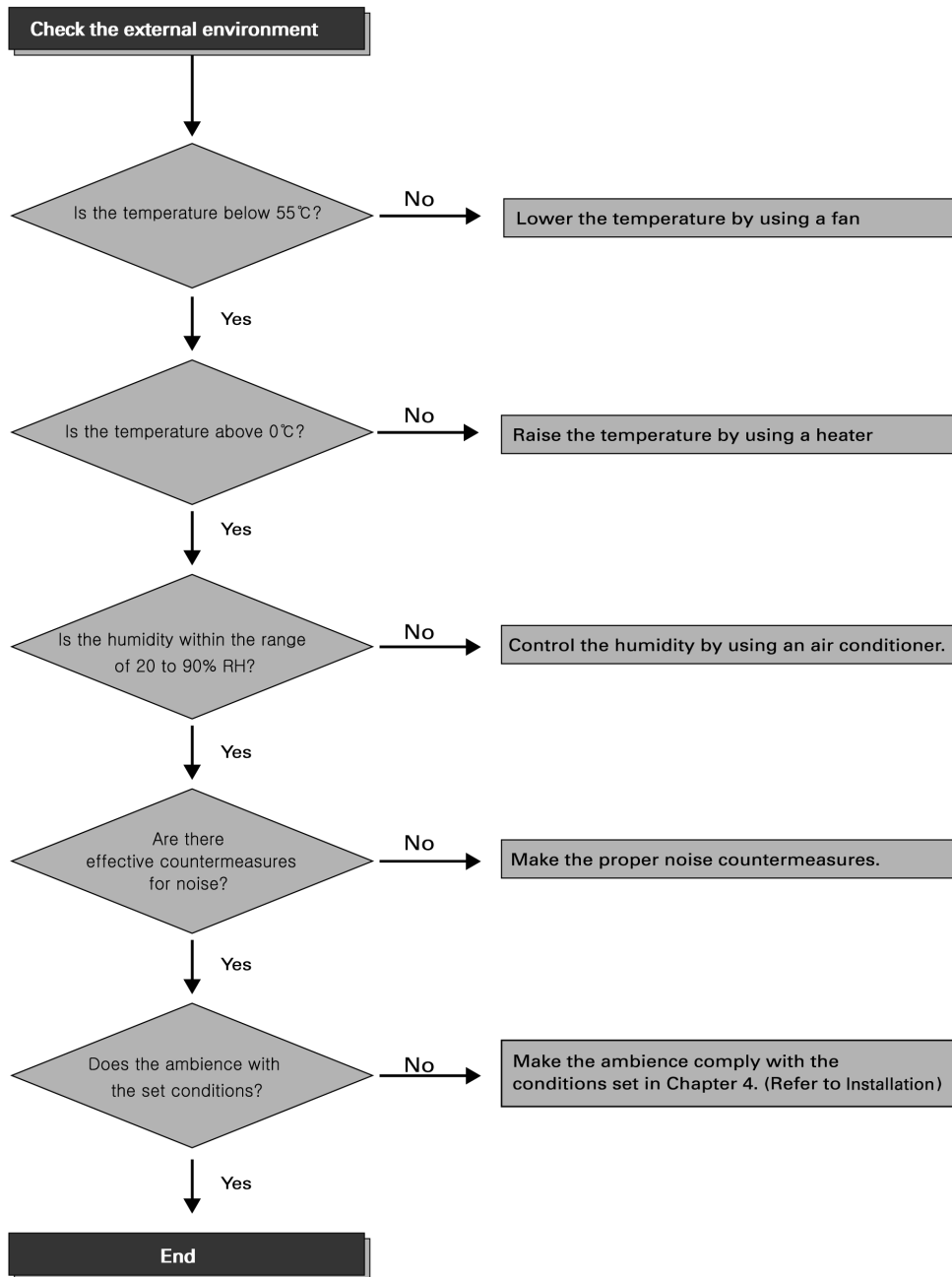

Inspection and Maintenance

Inspection and maintenance

Symptom	Possible cause	Action
Power supply LED will not illuminate.	Fuse blows	Replace the fuse
Fuse blows frequently.	Short circuit or defective part	Replace the power supply or the CPU module
Run LED will not illuminate.	Program errors	Correct the program
	Power line defect	Replace the CPU module
Output will not turn to On state during Run.	Short or open circuit	Replace the CPU module
I/O modules above a certain address will not operate.	I/O bus error	Replace the backplane module
Input or output module of only certain address will turn to On state.	I/O bus error	Replace the backplane module
Not all contacts on an output module operate properly.	I/O bus error	Replace the backplane module

Input module

Symptom	Possible cause	Action
No inputs on an input module will turn On (LEDs are not illuminated).	No external input power	Supply power
	Low external input voltage	Supply rated load power
	Loose terminal screw or defective contact	Tighten the screw and reconnect the module
Inputs will not turn to On state (LEDs are illuminated).	Defective input circuit	Replace the input module
Inputs will not turn to Off state.	Defective input circuit	Replace the input module
One or more inputs on an I/O module will not turn On.	Device connected to the input module is defective.	Replace the input device
	Loose input wiring	Reconnect the input wiring
	External input time is too short.	Adjust the input module
	Loose terminal screw or defective contact	Tighten the screw and reconnect the module
One or more inputs on an I/O module will not turn Off.	Defective input circuit	Replace the input module
Input changes On/Off state erratically.	Low external input voltage	Supply rated input voltage
	Noise error	Troubleshoot for noise
	Loose terminal screw or defective contact	Tighten the screw and reconnect the module
Input display LED will not illuminate (input is On in PLC).	LED error	Replace the input module

Output module

Symptom	Possible cause	Action
No outputs on an output module will turn On.	No external input power	Supply power
	Low external input voltage	Supply rated load power
	Loose terminal screw or defective contact	Tighten the screw and reconnect the module
	Defective I/O connector contacts	Replace the output module
	Defective output circuit	Reconnect the output module
No outputs on an output module will turn Off.	Defective output circuit	Replace the output module
One or more inputs on an I/O module will not change to On state (LED is illuminated).	Output time too short	Correct the program
	Defective output circuit	Replace the output module
One or more inputs on an I/O module will not change to On state (LED is not illuminated).	Incorrect output load	Replace the output load
	Short output wiring	Reconnect the output wiring
	Loose terminal screw or defective contact	Tighten screw and reconnect the module
	Defective output contact	Replace the output module or relay
	Defective output circuit	Replace the output module
One or more outputs on an I/O module will not change to On state (LED is illuminated).	Defective output circuit	Replace the output module or relay
	Error caused by leak or residual current	Replace the external load
One or more outputs on an I/O module will not turn Off (LED is not illuminated).	Defective output circuit	Replace the output module
Output changes On/Off state erratically.	Low external input voltage	Supply rated load power
	Noise error	Countermeasure against noise
	Loose terminal screw or defective contact	Tighten the screw and reconnect the module
A set of 8 points on an I/O module operate incorrectly or identically.	Loose common terminal screw	Tighten the screw and reconnect the module
	Defective terminal connector	Tighten the screw and reconnect the module
	CPU module error	Replace the CPU module
Output display LED is not illuminated.	LED error	Replace the output module

Periodic inspection and maintenance items

The NX70 series controllers require periodic inspection and maintenance for proper operation. The following items should be checked every six months, but the period can be shortened according to the operational environment.

Item	Check item	Requirement	Remarks
Supplied power	Does the voltage measured within the power terminal fall within the specified range?	Voltage must be within the power module input voltage specifications.	Voltmeter
Environment	Does the temperature fall within the specified range?	0 to 55 °C	Thermometer
	Does the humidity fall within the specified range?	35 to 85%RH	Hygrometer
	Is there any dust present?	No dust	Visual
I/O power	Does the control voltage supplied to the I/O modules fall within the specified limit?	Control voltage must be within the input and output modules specifications.	Voltmeter
Module mounting and wiring	Are all modules firmly mounted?	All should be firmly secured.	Screwdriver
	Is the connection cable firmly wired?		
	Is the external wiring screw tight?		
Life expectancy of parts	Contact relay	Electric lifetime: 100,000 to 300,000 operations	
	Battery	3 years at 25 °C	

Precautions when troubleshooting

- Always turn off the power whenever installing or removing modules.
- Check the module once more before replacing the defective part.
- Return the defective module for repair with any detailed information about its problems.
- When a contact is defective, clean the contact with a clean cotton and alcohol and then retest the module.
- Do not use thinner to clean since it might cause discoloration on the module's case.

Programming Instructions

IMPORTANT

Refer to the NX7/NX70 Instruction Set Reference Manual for detailed information on the NX7 and NX70 instruction set and for application examples to show the instruction set in use.

Basic Sequence Instructions

Mnemonic	Name	Ladder Symbol	Description
STR	Start		Starts contact A.
STN	Start Not		Starts contact B.
AND	And		Contact A series circuit
ANN	And Not		Contact B series circuit
OR	Or		Contact A parallel circuit
ORN	Or Not		Contact B parallel circuit
OUT	Out		Arithmetic result output
SET	Set		Sets output and retains On.
RST	Reset		Resets output and retains Off.
NOT	Not		Inverts circuit.
STR DIF	Start Differential		Starts rising edge contact ().
STR DFN	Start Dif. Not		Starts falling edge contact ().
AND DIF	And Dif.		Rising edge series connection ()
AND DFN	And Dif. Not		Falling edge series connection ()
OR DIF	Or Dif		Rising edge parallel connection ()
OR DFN	Or Dif. Not		Falling edge parallel connection ()
ANB	And Block		Circuit blocks series connection.
ORB	Or Block		Circuit blocks parallel connection.
MS	Master block Set		Starts master block. (for processor version 2.0 or higher)
MR	Master block Reset		Ends master block. (for processor version 2.0 or higher)
MCS	Master Control Set		Starts circuit branch.
MCR	Master Control Reset		Ends circuit branch.
-	Extension		Extension (Used in pairs with AND condition when extending. Exclusive for WinGPC, GPC5, etc)

Timer, Counter and Shift Register Instructions

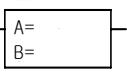
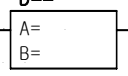
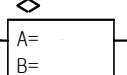
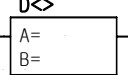
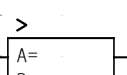
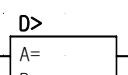
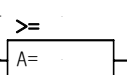
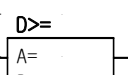
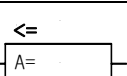
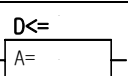
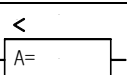
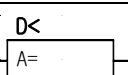

Mnemonic	Name	Ladder Symbol	Description	Remarks
TIM	On Delay Timer			Time base: Ch 0 to 63 = 0.01s Ch 64 to 255 = 0.1s Setting range: SV = 0 to 65535 Contact indicator: TC + channel number
TOF	Off Delay Timer			Time base: Ch 0 to 63 = 0.01s Ch 64 to 255 = 0.1s Setting range: SV = 0 to 65535 Contact indicator: TC + channel number
SST	Single Shot Timer			Time base: Ch 0 to 63 = 0.01s Ch 64 to 255 = 0.1s Setting range: SV = 0 to 65535 Contact indicator: TC + channel number
UC	Up Counter			Channel range: Ch 0 to 255 (Shared with timer) Setting range: SV = 0 to 65535 Contact indicator: TC + channel number
DC	Down Counter			Channel range: Ch 0 to 255 (Shared with timer) Setting range: SV = 0 to 65535 Contact indicator: TC + channel number
RCT	Ring Counter			Channel range: Ch 0 to 255 (Shared with timer) Setting range: SV = 0 to 65535 Contact indicator: TC + channel number
UDC	Up-Down Counter			Channel range: Ch 0 to 255 (Shared with timer) Setting range: SV = 0 to 65535 Contact indicator: TC + channel number
SR	Shift Register			Usable address areas for Sb and Eb : M, K 1 bit shift on each p input. Stores the status value I in Sb for every P input. Max. number of instructions: 256

Comparison Instructions

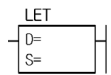
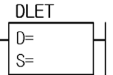
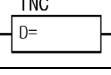
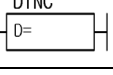
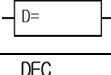
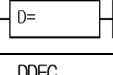
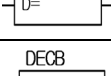
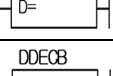

Mnemonic	Name	Word ladder symbol	Double word ladder symbol	Description
STR == AND == OR ==	START == AND == OR ==			On if A is equal to B. A and B are word/double word or data value.
STR <> AND <> OR <>	START <> AND <> OR <>			On if A is not equal to B. <> is same with ≠. A and B are word/double word or data value.
STR > AND > OR >	START > AND > OR >			On if A is greater than B.
STR >= AND >= OR >=	START >= AND >= OR >=			On if A is equal to or greater than B.
STR <= AND <= OR <=	START <= AND <= OR <=			On if A is equal to or less than B.
STR < AND < OR <	START < AND < OR <			On if A is less than B.

NOTE For double word comparison instructions, the letter D should precede the word comparison instructions in the Mnemonic program.

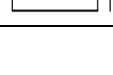
Substitution, Increment and Decrement Instructions

Mnemonic	Name	Word ladder symbol	Double word ladder symbol	Description
LET (DLET)	Let (Substitution)			Store the value of S into D.
INC (DINC)	Decimal increment			Increment D by 1 whenever input goes on.
INCB (DINCB)	BCD increment			Increment D by 1 in BCD mode whenever input goes on.
DEC (DDEC)	Decimal decrement			Decrement D by 1 whenever input goes on.
DECB (DDECB)	BCD decrement			Decrement D by 1 in BCD mode whenever input goes on.

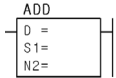
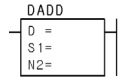
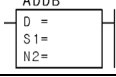
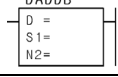
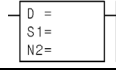
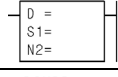
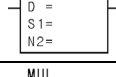
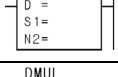
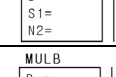
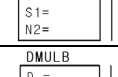
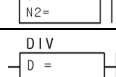
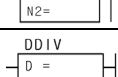
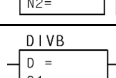
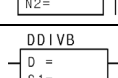
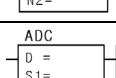
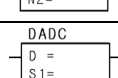
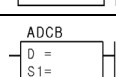
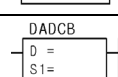
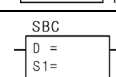
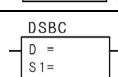
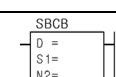
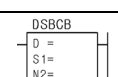
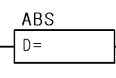
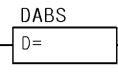
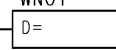
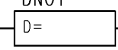
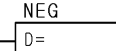
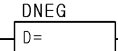
Arithmetic Instructions

Mnemonic	Name	Word ladder symbol	Double word ladder symbol	Description
ADD (DADD)	Decimal addition			$D = S1 + S2$ (Decimal operation)
ADDB (DADDB)	BCD addition			$D = S1 + S2$ (BCD operation)
SUB (DSUB)	Decimal subtraction			$D = S1 - S2$ (Decimal operation)
SUBB (DSUBB)	BCD subtraction			$D = S1 - S2$ (BCD operation)
MUL (DMUL)	Decimal multiplication			$D = S1 \times S2$ (Decimal operation)
MULB (DMULB)	BCD multiplication			$D = S1 \times S2$ (BCD operation)
DIV (DDIV)	Decimal division			$D = S1/S2$ (Decimal operation), Error when $S2 = 0$
DIVB (DDIVB)	BCD division			$D = S1/S2$ (BCD operation) Error when $S2 = 0$
ADC (DADC)	Decimal addition with carry			$D = S1 + S2 + CY$ (Decimal operation, include carry)
ADCB (DADCB)	BCD addition with carry			$D = S1 + S2 + CY$ (BCD operation, include carry)
SBC (DSBC)	Decimal subtraction with carry			$D = S1 - S2 - CY$ (Decimal operation, include carry)
SBCB (DSBCB)	BCD subtraction with carry			$D = S1 - S2 - CY$ (BCD operation, include carry)
ABS (DABS)	Absolute value			$D = D $ (Absolute value operation)
WNOT (DNOT)	NOT (1's complement)			Store 1's complement of D in D
NEG (DNEG)	Negative (2's complement)			Store 2's complement of D in D (1's complement + 1) (- Result)

Logical Instructions

Mnemonic	Name	Word ladder symbol	Double word ladder symbol	Description															
WAND (DAND)	AND (logical multiply)			Store AND of S1 and S2 in D <table border="1" style="font-size: small;"> <tr><td>S1</td><td>0</td><td>0</td><td>1</td><td>1</td></tr> <tr><td>S2</td><td>0</td><td>1</td><td>0</td><td>1</td></tr> <tr><td>D</td><td>0</td><td>0</td><td>0</td><td>1</td></tr> </table>	S1	0	0	1	1	S2	0	1	0	1	D	0	0	0	1
S1	0	0	1	1															
S2	0	1	0	1															
D	0	0	0	1															
WOR (DOR)	OR (logical sum)			Store OR of S1 and S2 in D <table border="1" style="font-size: small;"> <tr><td>S1</td><td>0</td><td>0</td><td>1</td><td>1</td></tr> <tr><td>S2</td><td>0</td><td>1</td><td>0</td><td>1</td></tr> <tr><td>D</td><td>0</td><td>1</td><td>1</td><td>1</td></tr> </table>	S1	0	0	1	1	S2	0	1	0	1	D	0	1	1	1
S1	0	0	1	1															
S2	0	1	0	1															
D	0	1	1	1															
WXOR (DXOR)	Exclusive OR (exclusive logical sum)			Store exclusive OR of S1 and S2 in D <table border="1" style="font-size: small;"> <tr><td>S1</td><td>0</td><td>0</td><td>1</td><td>1</td></tr> <tr><td>S2</td><td>0</td><td>1</td><td>0</td><td>1</td></tr> <tr><td>D</td><td>0</td><td>1</td><td>1</td><td>0</td></tr> </table>	S1	0	0	1	1	S2	0	1	0	1	D	0	1	1	0
S1	0	0	1	1															
S2	0	1	0	1															
D	0	1	1	0															
WXNR (DXNR)	Exclusive OR NOT (equivalence)			Store exclusive OR NOT of S1 and S2 in D 1 (ON if they are equal) <table border="1" style="font-size: small;"> <tr><td>S1</td><td>0</td><td>0</td><td>1</td><td>1</td></tr> <tr><td>S2</td><td>0</td><td>1</td><td>0</td><td>1</td></tr> <tr><td>D</td><td>1</td><td>0</td><td>0</td><td>1</td></tr> </table>	S1	0	0	1	1	S2	0	1	0	1	D	1	0	0	1
S1	0	0	1	1															
S2	0	1	0	1															
D	1	0	0	1															

Rotation Instructions

Mnemonic	Instruction	Word ladder symbol	Double word ladder symbol	Description
RLC (DRLC)	Rotate left without carry			Rotate the content of D to the left N times. (lower -> higher)
RRC (DRRC)	Rotates right without carry			Rotate the content of D to the right N times (higher -> lower)
ROL (DROL)	Rotate left with carry			Rotate (shift) to the left N times (Input F1.8 value to the lowest bit)
ROR (DROR)	Rotate right with carry			Rotate (shift) to the right N times (higher -> lower) (Input F1.8 value to the highest bit)
SHL (DSHL)	Shift left			Shift the content of D to the left N times (input 0 to the lowest bit)
SHR (DSHR)	Shift right			Shift the content of D to the right N times (input 0 to the highest bit)

Word Conversion Instructions

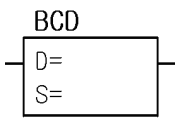
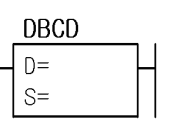
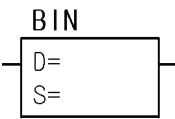
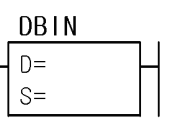
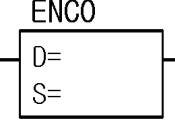
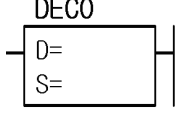
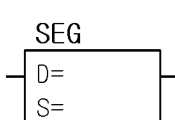
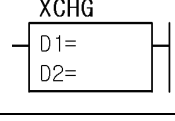
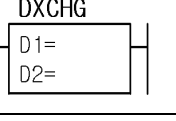
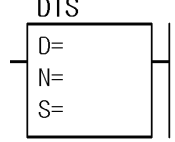
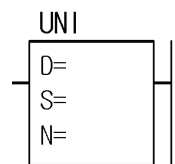
Mnemonic	Name	Word ladder symbol	Double word ladder symbol	Description
BCD (DBCD)	BCD Conversion			Convert binary value of S to BCD and store it in D. S $\dots 00111111 = 63(\text{DEC})$ D $\dots 01110001 = \$63(\text{BCD})$
BIN (DBIN)	Binary Conversion			Convert BCD of S to binary number and store it in D. S $\dots 010111001 = \$39(\text{BCD})$ D $\dots 00100111 = 39(\text{DEC})$
ENCO	Encode		_____	Store the location of the highest set bit in S in D. S $\dots 001111000 = 2^6$ D $\dots 00000110 = 6$ Note) It is different than function of SPC series ($2^n + 1$)
DECO	Decode		_____	Convert the low-order 4-bit value of S to a power of 2 (2^S) and store it in D. S $\dots \text{xxxx}0101 = 5$ D $\dots 00010000$
SEG	7-Segment		_____	Converts the low-order 4-bit value of S to 7-segment display pattern and store them in D. S $\dots 00001011$ D $\dots 01101101$
XCHG (DXCHG)	Exchange			Exchange D1 and D2 values. D1 $\dots 0101$ \leftrightarrow D1 $\dots 0011$ D2 $\dots 0011$ \leftrightarrow D2 $\dots 0101$
DIS	Dissemble		_____	Separate S into N+1 units, 4 bits each, and store them in the low 4 bits of words starting at D. When S=\$7325, 0111100110010010101 When N=3, $\begin{cases} D & \dots 001101 = 5 \\ D+1 & \dots 000110 = 2 \\ D+2 & \dots 000111 = 3 \\ D+3 & \dots 001111 = 7 \end{cases}$
UNI	Unify		_____	Combine the low 4 bits of S+1 words starting at S, and store them in D (N= 0 to 3). When N=3, $\begin{cases} S & \dots 001101 = 5 \\ S+1 & \dots 000110 = 2 \\ S+2 & \dots 000111 = 3 \\ S+3 & \dots 001111 = 7 \end{cases}$ D=\$7325 0111100110010010101

Bit Conversion Instructions

Mnemonic	Name	Word ladder symbol	Double word ladder symbol	Description																								
BSET	Bit Set		_____	Set N th bit of D to 1. D <table border="1" style="display: inline-table; border-collapse: collapse;"><tr><td>.....</td><td>0</td><td>0</td><td>1</td><td>0</td><td>0</td><td>1</td><td>0</td><td>0</td></tr></table> When N=15 <table border="1" style="display: inline-table; border-collapse: collapse;"><tr><td> </td><td>↑</td><td> </td></tr></table> 1 (N=0~15)	0	0	1	0	0	1	0	0		↑													
.....	0	0	1	0	0	1	0	0																				
	↑																											
BRST	Bit Reset		_____	Reset N th bit of D to 0. D <table border="1" style="display: inline-table; border-collapse: collapse;"><tr><td>.....</td><td>0</td><td>1</td><td>0</td><td>1</td><td>0</td><td>1</td><td>0</td><td>0</td></tr></table> When N=3 <table border="1" style="display: inline-table; border-collapse: collapse;"><tr><td> </td><td>↑</td><td>0</td></tr></table>	0	1	0	1	0	1	0	0		↑	0												
.....	0	1	0	1	0	1	0	0																				
	↑	0																										
BNOT	Bit Not		_____	Invert N th bit of D. D <table border="1" style="display: inline-table; border-collapse: collapse;"><tr><td>.....</td><td>0</td><td>1</td><td>1</td><td>1</td><td>0</td><td>1</td><td>0</td><td>0</td></tr></table> When N=4 <table border="1" style="display: inline-table; border-collapse: collapse;"><tr><td> </td><td>↓</td><td> </td></tr></table> D <table border="1" style="display: inline-table; border-collapse: collapse;"><tr><td>.....</td><td>0</td><td>1</td><td>1</td><td>0</td><td>0</td><td>1</td><td>0</td><td>0</td></tr></table>	0	1	1	1	0	1	0	0		↓		0	1	1	0	0	1	0	0			
.....	0	1	1	1	0	1	0	0																				
	↓																											
.....	0	1	1	0	0	1	0	0																				
BTST	Bit Test		_____	Store the value of N th bit of D to F1.8. D <table border="1" style="display: inline-table; border-collapse: collapse;"><tr><td>.....</td><td>0</td><td>1</td><td>1</td><td>1</td><td>0</td><td>1</td><td>0</td><td>0</td></tr></table> When N=6 <table border="1" style="display: inline-table; border-collapse: collapse;"><tr><td> </td><td>→</td><td> </td></tr></table> <table border="1" style="display: inline-table; border-collapse: collapse;"><tr><td>F1.8</td></tr></table>	0	1	1	1	0	1	0	0		→		F1.8											
.....	0	1	1	1	0	1	0	0																				
	→																											
F1.8																												
SUM	Sum		_____	Store the number of bits in S that are 1 to D. S <table border="1" style="display: inline-table; border-collapse: collapse;"><tr><td>0</td><td>0</td><td>0</td><td>1</td><td>1</td><td>0</td><td>1</td><td>0</td><td>1</td><td>0</td><td>0</td><td>1</td></tr></table> No of 1=7 D <table border="1" style="display: inline-table; border-collapse: collapse;"><tr><td>0</td><td>0</td><td>0</td><td>0</td><td>0</td><td>0</td><td>0</td><td>0</td><td>0</td><td>1</td><td>1</td><td>1</td></tr></table> D=7	0	0	0	1	1	0	1	0	1	0	0	1	0	0	0	0	0	0	0	0	0	1	1	1
0	0	0	1	1	0	1	0	1	0	0	1																	
0	0	0	0	0	0	0	0	0	1	1	1																	
SC	Set Carry		_____	Set carry bit (F1.8) to 1. 1 <table border="1" style="display: inline-table; border-collapse: collapse;"><tr><td>→</td></tr></table> <table border="1" style="display: inline-table; border-collapse: collapse;"><tr><td>F1.8</td></tr></table>	→	F1.8																						
→																												
F1.8																												
RC	Reset Carry		_____	Reset carry bit (F1.8) to 0. 0 <table border="1" style="display: inline-table; border-collapse: collapse;"><tr><td>→</td></tr></table> <table border="1" style="display: inline-table; border-collapse: collapse;"><tr><td>F1.8</td></tr></table>	→	F1.8																						
→																												
F1.8																												
CC	Complement Carry		_____	Invert carry bit (F1.8). <table border="1" style="display: inline-table; border-collapse: collapse;"><tr><td>F1.8</td></tr></table> <table border="1" style="display: inline-table; border-collapse: collapse;"><tr><td>→</td></tr></table> <table border="1" style="display: inline-table; border-collapse: collapse;"><tr><td>F1.8</td></tr></table> 1 <table border="1" style="display: inline-table; border-collapse: collapse;"><tr><td>→</td></tr></table> 0 0 <table border="1" style="display: inline-table; border-collapse: collapse;"><tr><td>→</td></tr></table> 1	F1.8	→	F1.8	→	→																			
F1.8																												
→																												
F1.8																												
→																												
→																												



Move Instructions

Mnemonic	Name	Word ladder symbol	Double word ladder symbol	Description												
MOV	Move		_____	Copy Ns words from Sr to D. 												
FMOV	Fill Move		_____	Repeatedly copy the value V to the Ns words starting from D. 												
BMOV	Bit Move		_____	Move Ns bits from the bit address Sb to the bit address Db. 												
BFMV	Bit Fill Move		_____	Repeatedly copy the bit value V to the N bits starting from the bit address Db. (V=0, 1)(N=1...256) (Db is bit address) When V=1, N=5 												
LDR (DLDR)	Load D ←(S)			Store to D the value of the register whose absolute address is the value of S. (Refer to the manual for information about absolute address.) <table border="1" style="margin-left: auto; margin-right: auto;"> <thead> <tr> <th>Register address</th> <th>absolute address</th> <th>data value</th> </tr> </thead> <tbody> <tr> <td>S =</td> <td></td> <td>X</td> </tr> <tr> <td>?</td> <td>X</td> <td>Y</td> </tr> <tr> <td>D =</td> <td></td> <td>Y</td> </tr> </tbody> </table>	Register address	absolute address	data value	S =		X	?	X	Y	D =		Y
Register address	absolute address	data value														
S =		X														
?	X	Y														
D =		Y														
STO (DSTO)	Store (D) ←S			Store the value of S to the register whose absolute address is the value of D. (Refer to the manual for information about absolute address.) <table border="1" style="margin-left: auto; margin-right: auto;"> <thead> <tr> <th>Register address</th> <th>absolute address</th> <th>data value</th> </tr> </thead> <tbody> <tr> <td>S =</td> <td></td> <td>X</td> </tr> <tr> <td>D =</td> <td>Y</td> <td>Y</td> </tr> <tr> <td>?</td> <td>Y</td> <td>X</td> </tr> </tbody> </table>	Register address	absolute address	data value	S =		X	D =	Y	Y	?	Y	X
Register address	absolute address	data value														
S =		X														
D =	Y	Y														
?	Y	X														

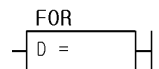
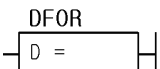
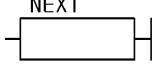
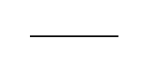
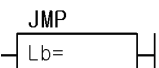
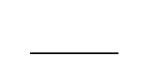
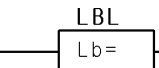
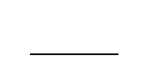
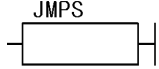
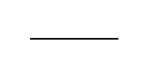
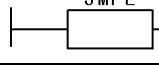
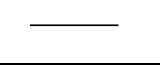
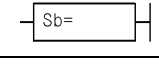
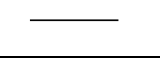
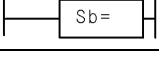
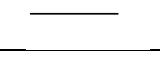
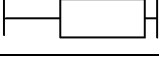
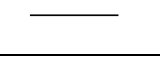
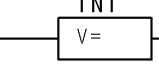
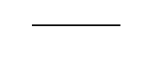
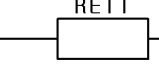
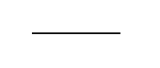
Program Control Instructions

Mnemonic	Name	Word ladder symbol	Double word ladder symbol	Description
FOR (DFOR)	For Loop			Execute instructions in the block between FOR and corresponding NEXT. Repeat execution D times.
NEXT	Next			Decrement D of FOR instruction by 1. If it is not zero, repeat execution from FOR instruction.
JMP	Jump			Jump to the position marked LBL L (label number). (L: 0 to 63)
LBL	Label			Position jumped to by the corresponding JMP instruction. (L:0 to 63)
JMPS	Jump Start			Jump to the JMPE instruction.
JMPE	Jump End			Position jumped to by the corresponding JMPS instruction.
CALL	Call Subroutine			Call subroutine Sb. (Sb = 0 to 63)
SBR	Subroutine Start			Start subroutine Sb. (Sb = 0 to 63)
RET	Subroutine Return			End of subroutine. Return execution to the instruction after CALL.
INT	Begin Interrupt			Begin the block of constant cycle scan instructions. Ni = 1 to 999 (20 msec to 10 sec) Constant cycle time = (Ni+1) x 0.01 sec
RETI	Return Interrupt			End the block of constant cycle scan instructions.

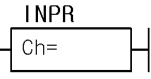
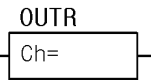
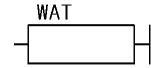
System Control Instructions

Mnemonic	Name	Word ladder symbol	Double word ladder symbol	Description
INPR	Input Refresh		_____	Refresh external input (Receive input signal during program execution). Ch is external input word address.
OUTR	Output Refresh		_____	Refresh external output (Send output signal during program execution). Ch is external output word address.
WAT	Watchdog Timer		_____	Clear watchdog scan time.
END	END		_____	End of program. This instruction is automatically added by WinGPC.

Communications Control Instructions

Mnemonic	Name	Word ladder symbol	Double word ladder symbol	Description
READ	Read Data (from shared memory of high performance module)		—	Read NR3 words from the module memory address NR6 of the slot NN5, and write them to the words starting from RR1.
WRITE	Write Data (to shared memory of high performance module)		—	Read NR3 words from NR5, and write them to the module memory address NR2 of slot NN1.
RMRD	Read Remote Slave Data (from shared memory of high performance module)		—	Read NR1 words from the module memory address NR6 of the slot NN5 for the station NN4 on the remote network loop NN3, and write them in words starting at RR2.
RMWR	Write Remote Slave Data (to shared memory of high performance module)		—	Read NR5 words from the module memory address NR6, and write them to the words starting from NR4 of the slot NN3 in the station NN2 on the remote network loop NN1.
RECV	Receive Link Data Word		—	Read NR1 words from the module memory NR6 of the slot NN5 in the station NN4 on the link network loop NN3, and write them to the words starting from RR2.
SEND	Send Link Data Word		—	Read NR5 words from the module memory NR6, and write them to the module memory starting from NR4 of the slot NN3 in the station NN2 on the link network loop NN1.
RECVB	Receive Link Data Bit		—	Read the bit NR6 of the slot NN5 in the station NN4 on the link network loop NN3, and write it the bit register BR1.
SENDB	Send Link Data Bit		—	Write the content of bit NB5 to the bit NR4 of the slot NN3 in the station NN2 on the link network loop NN1.

Catalog Numbers and Dimensions

NX70 Product Catalog Numbers

Processor module

Using WinGPC as programming device

Module	Catalog number	Specifications	Remarks
CPU module	NX70-CPU70p1	<ul style="list-style-type: none"> 9.6k step (built-in), 0.2 μs per step, built-in flash ROM general CPU module 	
	NX70-CPU70p2	<ul style="list-style-type: none"> 20k step (built-in), 0.2 μs per step, 2 ports, real time clock (RTC) function, built-in flash ROM, proportional integral differential (PID) function Advanced CPU module 	

Processor communication cable

Module	Catalog number	Specifications	Remarks
Processor communication cable	NX_CBLCPU2	2 m	Communication cable for NX70, NX700 processor module
	NX_CBLCPU5	5 m	

Backplane

Module	Catalog number	Specifications	Remarks
Backplane	NX70-BASE02	2-slot type	The NX70 series PLC is not expandable.
	NX70-BASE03	3-slot type	
	NX70-BASE05	5-slot type	
	NX70-BASE06	6-slot type	
	NX70-BASE08	8-slot type	
	NX70-BASE10	10-slot type	
	NX70-BASE12	12-slot type	

Power supply module

Module	Catalog number	Specifications	Remarks
Power supply module	NX70-POWER1	110 to 220V ac free voltage, 4A at 5V, 0.3A at 24V	AC input type
	NX70-POWER2	110 to 220V ac free voltage, 4.5A at 5V	
	NX70-PWRDC	24V dc input, 4.5A at 5V	DC input type

I/O modules

Module		Catalog number	Specifications	Remarks
Input module	16 points	NX70-X16D	12 to 24V dc, 20-pin terminal board, 8 points per COM (both + and - polarities are available.)	Terminal type
		NX70-X16D1	24V dc, 20-pin terminal board, 8 points per COM (both + and - polarities are available.)	
		NX70-X16A110	100 to 120V ac, 20-pin terminal board, 8 points per COM	
		NX70-X16A220	200 to 240V ac, 20-pin terminal board, 8 points per COM	
	32 points	NX70-X32D	12 to 24V dc, two 20-pin connectors, 8 points per COM (both + and - polarities are available.)	Connector type
		NX70-X32D1	24V dc, two 20-pin connectors, 8 points per COM (both + and - polarities are available.)	
Output module	8 points	NX70-Y8R	Relay output, 20-pin terminal board, 3A at 250V (one 4 points per COM, four 1 point per COM)	Terminal type
	16 points	NX70-Y16R	Relay output, 20-pin terminal board, 1A at 250V, 8 points per COM	
		NX70-Y16RV	Relay output, 20-pin terminal board, 1A at 250V, 8 points per COM, Varistor	
		NX70-Y16T	TR output (NPN), 20-pin terminal board, 0.6A at 12 to 24V, 8 points per COM	
		NX70-Y16SSR	SSR output, 20-pin terminal board, 0.5A at 100 to 220V, 8 points per COM	
	32 points	NX70-Y32T	TR output (NPN), two 20-pin connectors, 0.4A at 12 to 24V, 16 points per COM (-)	Connector type
		NX70-Y32P	TR output (PNP), two 20-pin connectors, 0.4A at 12 to 24V, 16 points per COM (+)	
	Mixed module	16 points	NX70-XY16	<ul style="list-style-type: none"> • 12 to 24V dc, 8 points, 8 points per COM (both + and - polarities are available.) • Relay output, 8 points, 1A at 250V, 8 points per COM, 20-pin terminal board
32 points		NX70-XY32	<ul style="list-style-type: none"> • 12 to 24V dc, 16 points, 16 points per COM (both + and - polarities are available.), two 20-pin connectors • TR output (NPN) 16 points, 0.4A at 12 to 24V, 16 points per COM 	Input 16 points, Output 16 points (To be released)
Dummy module		NX70-DUMMY	Dummy Module	

Analog module

Module	Catalog number	Specifications	Remarks
Analog input module (A/D) (For both voltage and current)	NX70-AI4CV	4 channels, voltage input, 16-bit A/D Converter, $\pm 5V$, $\pm 10V$, 0 to 5V, 0 to 10V Resolution (0.153 mV to 1.0 mV), Conversion speed 1.25 ms/Ch Current Input, 16-bit A/D Converter, ± 20 mA, 0 to 20 mA, 4 to 20 mA Resolution (0.519 μA to 2.0 μA), Conversion speed 1.25 ms/Ch	20-pin terminal type
Analog output module (D/A)	NX70-AO4V	4 channels, voltage output, 14-bit D/A Converter, $\pm 10V$, $\pm 5V$, 0 to 10V, 0 to 5V Resolution (0.305 mV to 1.0 mV), Conversion speed 2.5 ms/Ch	
	NX70-AO4C	4 channels, current output, 14-bit D/A Converter, 0 to 20 mA, 4 to 20 mA Resolution (0.037 μA to 2.0 μA) 4 μA , Conversion speed 2.5 ms/Ch	
	NX70-AO2V	2 channels, voltage output, 14-bit D/A Converter, $\pm 10V$, $\pm 5V$, 0 to 10V, 0 to 5V Resolution (0.305 mV to 1.0 mV), Conversion speed 2.5 ms/Ch	
	NX70-AO2C	2 channels, current output, 14-bit D/A Converter, 0 to 20 mA, 4 to 20 mA Resolution (0.037 μA to 2.0 μA) 4 μA , Conversion speed 2.5 ms/Ch	
Resistance temperature detector (RTD) module	NX70-RTD4	4 channels, 3-Wire type, Pt100, Pt200, Pt500, Pt1000, JPt100, JPt200, JPt500, JPt1000, NI100, NI120, CU50, 300 Ω , 600 Ω , 2000 Ω Resolution 0.1 $^{\circ}C$, 0.1 $^{\circ}F$, 10 m Ω , 20 m Ω , Conversion speed 60 ms/Ch	
Thermocouple input module	NX70-TC4	4 channels, Type: B/ R/ S/ N/ K/ E/ J/ T (The temperature range differs depending on the sensor type.) ± 30 mV (1 μV /bit), ± 60 mV (2 μV /bit) Resolution 0.1 $^{\circ}C$ /0.1F/1 μV /2 μV , Conversion speed 60 ms/Ch	

Communications module

Module	Catalog number	Specifications	Remarks
Serial communication module (SCU)	NX70-SCU	RS232C/RS485, 2 ports (Data processing with ladder program) <ul style="list-style-type: none"> transmits and receives data through RS232C/RS485 communication devices (<u>Binary/ASCII code</u>) connects to a networked inverter, a networked servo, and a networked temperature controller has the networking function of the RS485 added to the existing SDU functions 	The function of RS485 is added to the existing SDU functions

Motion Control Module

Module	Catalog number	Specifications	Remarks
High-speed counter	NX70-HSC1	1 channel of a high-speed counter input and a simple pulse output (200 Hz to 40 kHz) 24-bit binary up/down counter (-16,777,216 to 16,777,215)	Includes simple pulse output function
	NX70-HSC2	2 channels of a high-speed counter input 24-bit binary up/down counter (-16,777,216 to 16,777,215)	
High-speed counter 4	NX70-HSC4	4 channels of high-speed counter input, 8 points of a interrupt input, and 8 points of a comparison output - 200 kcps, 32-bit binary up/down counter (-2,147,483,648 to 2,147,483,647) - Multiplication (x1, x2, x4), Input time constant setting (4,8,16,32W/us), pulse width: 2.5 us	
Pulse I/O module	NX70-PULSE4	Multi-function module: 4 channels of pulse output, 4 channels of PWM output, 4 channels of high-speed counter input, 8 points of interrupt input, and 8 points of comparison output - High-speed counter input: 200 kcps, 32-bit binary up/down counter, etc. - Pulse output: 100 KHz output at 1 Hz module, direction control, and individual input (CW, CCW) - PWM output: 30 KHz output at 1 Hz module, Duty: 0 to 100% at 1% module * Function: NX70-HSC4 + pulse output (4 channels) + PWM output (4 channels)	

Networking module

Module	Catalog number	Specifications	Remarks
Multi Wire-Link module	NX70-MWLINK	W-Link function (W-mode) <ul style="list-style-type: none"> Functions: PLC link: 16 stations Computer link Data transmission (16 words per instruction) Remote programming Total of 2 layers with 32 stations per layer. Transmission speed: 0.5 Mbps Transmission distance: total 800m, Interface: RS-485 multi-drop 	Using twisted-pair cables
DeviceNet Slave module	NX70-DNS	DeviceNet slave module for NX70 PLC. High-speed photocoupler, 125K250K, 500Kbps Supported software: SYCON (NCS-DN)	

Operator interface and programming device

Module	Catalog number	Specifications	Applicable model	Remarks
Programming device	WinGPC (for Windows)	<ul style="list-style-type: none"> Writing PLC programs and checking PLC status on a computer. Network check-up, I/O mapping and monitoring, file managing and saving, online editing, error searching, and time chart monitoring. The current version of WinGPC (for Windows) is version 3.xx. 	<ul style="list-style-type: none"> NX7 PLC NX70 PLC (NX70-CPU70p1) (NX70-CPU70p2) 	Windows 95 or higher

CPU module communication cable

Communication port name	Catalog number	Specifications	Description	Remarks
CPU communication cable	NX-CBLCPU2	2m	For connecting to WinGPC	Refer to the communication pin specifications
	NX-CBLCPU5	5m		

Input/Output Harness

Module	Catalog number	Specifications	Remarks
I/O cable ASS'Y	NX70 I/O (connector type)	NX_70CBLDC	Harness length: 1.5 m No. of pins: 20 pins
		NX70_CBLTR	
I/O connector ASS'Y	NX70 I/O (connector type)	NX_PIN20	20 pins (connector hood included) For the connector type of NX70, N70, and N700 I/O

NX70 Product Dimensions

System dimensions (mm)

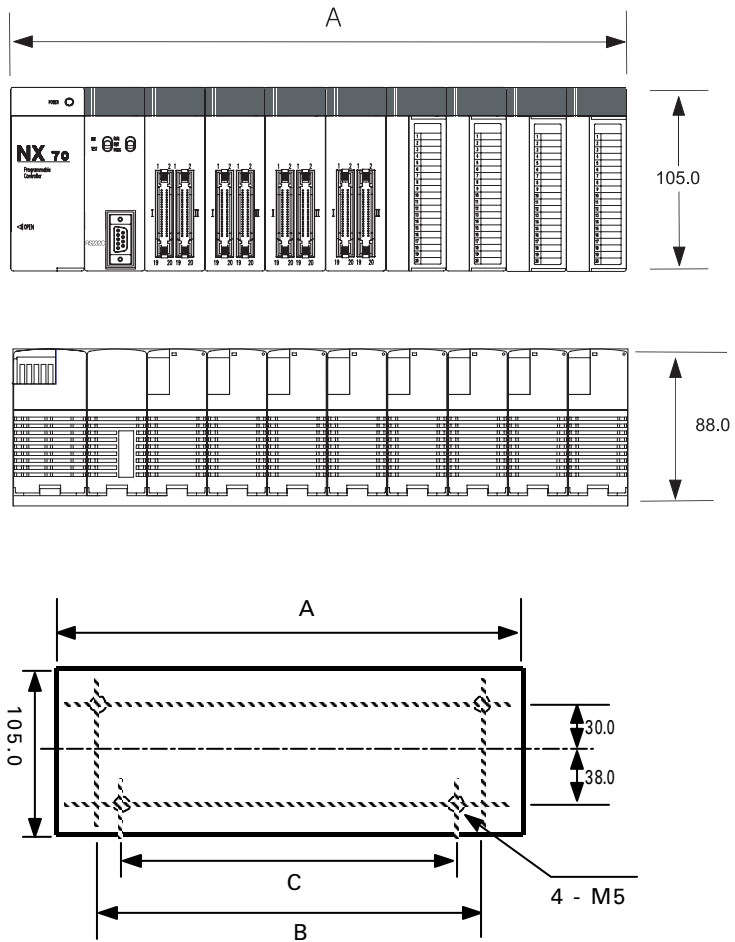

Slot type	Catalog number	Size A	Size B	Size C
2-slot type	NX70-BASE02	149.5	129.5	115.5
3-slot type	NX70-BASE03	185.0	165.0	151.0
5-slot type	NX70-BASE05	256.0	236.0	222.0
6-slot type	NX70-BASE06	291.5	271.5	257.5
8-slot type	NX70-BASE08	362.5	342.5	328.5
10-slot type	NX70-BASE10	398.0	378.0	364.0
12-slot type	NX70-BASE12	433.5	413.5	399.5

Power supply module dimensions (mm)

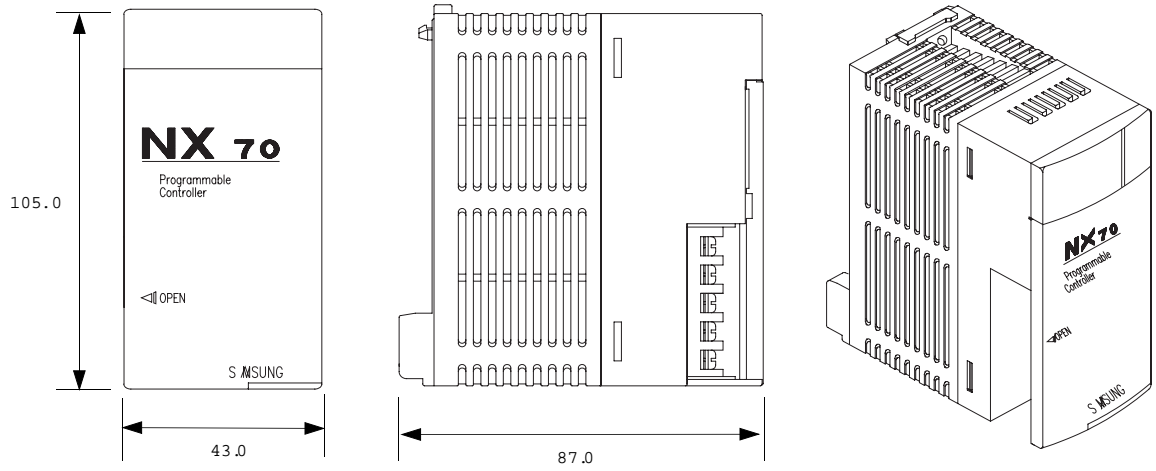

Processor and I/O modules dimensions (mm)

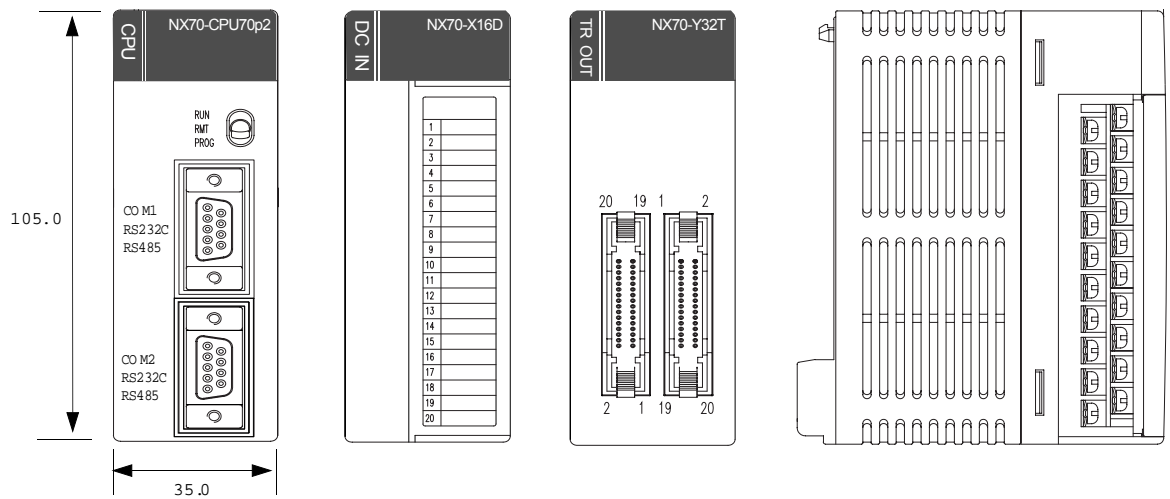

Specialty module dimensions (mm)

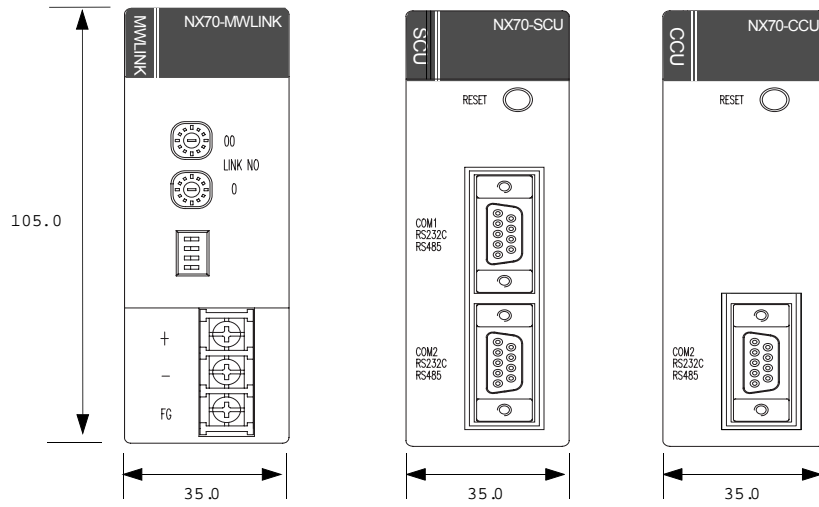

NX-IO link module dimension (mm)

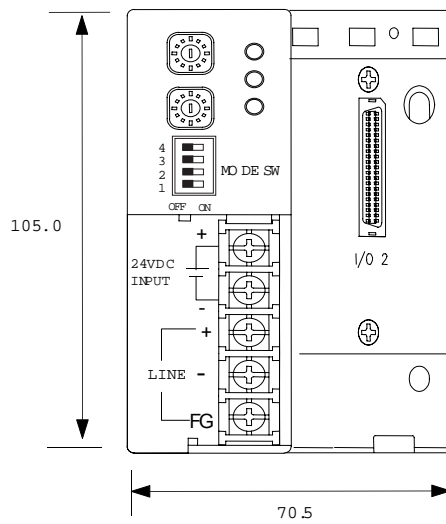

Decimal, Bin, Hex, BCD, Gray Code Cross-reference Table

Decimal	Hexadecimal	Binary	Binary coded decimal	Gray code
0	0000	00000000 00000000	0000 0000 0000 0000	0000 0000 0000 0000
1	0001	00000000 00000001	0000 0000 0000 0001	0000 0000 0000 0001
2	0002	00000000 00000010	0000 0000 0000 0010	0000 0000 0000 0011
3	0003	00000000 00000011	0000 0000 0000 0011	0000 0000 0000 0010
4	0004	00000000 00000100	0000 0000 0000 0100	0000 0000 0000 0110
5	0005	00000000 00000101	0000 0000 0000 0101	0000 0000 0000 0111
6	0006	00000000 00000110	0000 0000 0000 0110	0000 0000 0000 0101
7	0007	00000000 00000111	0000 0000 0000 0111	0000 0000 0000 0100
8	0008	00000000 00001000	0000 0000 0000 1000	0000 0000 0000 1100
9	0009	00000000 00001001	0000 0000 0000 1001	0000 0000 0000 1101
10	000A	00000000 00001010	0000 0000 0001 0000	0000 0000 0000 1111
11	000B	00000000 00001011	0000 0000 0001 0001	0000 0000 0000 1110
12	000C	00000000 00001100	0000 0000 0001 0010	0000 0000 0000 1010
13	000D	00000000 00001101	0000 0000 0001 0011	0000 0000 0000 1011
14	000E	00000000 00001110	0000 0000 0001 0100	0000 0000 0000 1001
15	000F	00000000 00001111	0000 0000 0001 0101	0000 0000 0000 1000
16	0010	00000000 00010000	0000 0000 0001 0110	0000 0000 0001 1000
17	0011	00000000 00010001	0000 0000 0001 0111	0000 0000 0001 1001
18	0012	00000000 00010010	0000 0000 0001 1000	0000 0000 0001 1011
19	0013	00000000 00010011	0000 0000 0001 1001	0000 0000 0001 1010
20	0014	00000000 00010100	0000 0000 0010 0000	0000 0000 0001 1110
21	0015	00000000 00010101	0000 0000 0010 0001	0000 0000 0001 1111
22	0016	00000000 00010110	0000 0000 0010 0010	0000 0000 0001 1101
23	0017	00000000 00010111	0000 0000 0010 0011	0000 0000 0001 1100
24	0018	00000000 00011000	0000 0000 0010 0100	0000 0000 0001 0100
25	0019	00000000 00011001	0000 0000 0010 0101	0000 0000 0001 0101
26	001A	00000000 00011010	0000 0000 0010 0110	0000 0000 0001 0111
27	001B	00000000 00011011	0000 0000 0010 0111	0000 0000 0001 0110
28	001C	00000000 00011100	0000 0000 0010 1000	0000 0000 0001 0010
29	001D	00000000 00011101	0000 0000 0010 1001	0000 0000 0001 0011
30	001E	00000000 00011110	0000 0000 0011 0000	0000 0000 0001 0001
31	001F	00000000 00011111	0000 0000 0011 0001	0000 0000 0001 0000
32	0020	00000000 00100000	0000 0000 0011 0010	0000 0000 0011 0000
63	003F	00000000 00111111	0000 0000 0110 0011	0000 0000 0010 0000
64	0040	00000000 01000000	0000 0000 0110 0011	0000 0000 0110 0000
255	00FF	00000000 11111111	0000 0010 0101 0101	0000 0000 0110 0000

ASCII Code Table

b8	b7	b6	b5	b4	b3	b2	b1		b8								
									b7	0	0	0	0	1	1	1	1
									b6	0	0	1	1	0	0	1	1
									b5	0	1	0	1	0	1	0	1
									b4								
									b3								
									b2								
									b1								
									R \ C	0	1	2	3	4	5	6	7
				0	0	0	0	0	NUL	DEL	SPACE	0	@	P	`	p	
				0	0	0	1	1	SOH	DC ₁	!	1	A	Q	a	q	
				0	0	1	0	2	STX	DC ₂	"	2	B	R	b	r	
				0	0	1	1	3	ETX	DC ₃	#	3	C	S	c	s	
				0	1	0	0	4	EOT	DC ₄	\$	4	D	T	d	t	
				0	1	0	1	5	ENQ	NAK	%	5	E	U	e	u	
				0	1	1	0	6	ACK	SYN	&	6	F	V	f	v	
				0	1	1	1	7	BEL	ETB	'	7	G	W	g	w	
				1	0	0	0	8	BS	CAN	(8	H	X	h	x	
				1	0	0	1	9	HT	EM)	9	I	Y	i	y	
				1	0	1	0	A	LF	SUB	*	:	J	Z	j	z	
				1	0	1	1	B	VT	ESC	+	;	K	[k	{	
				1	1	0	0	C	FF	FS	,	<	L	W	l		
				1	1	0	1	D	CR	GS	-	=	M]	m	}	
				1	1	1	0	E	SO	RS	.	>	N	^	n	~	
				1	1	1	1	F	SI	US	/	?	O	_	o	DEL	

Appendix

Communication Protocols for NX70

The communication protocol of NX70-CPU70p1 and CPU70p2 PLCs provides a complete method of communications between the graphic consol programmers (WinGPC) and the PLC by controlling programs, CPU status, and I/O at user's convenience. The user can easily expand the capabilities of the overall PLC system by communicating to the PLC using a variety of peripheral communications equipment in accordance with the following communication protocols and procedures. Additionally, the communications protocol allows for the PLCs to communicate to a central computer on a single network using RS485, at a distance of up to 1.2 km (RS232C, 15 m).

Communication Protocols for NX70 (NX70-CPU70p1 and NX70-CPU70p2)

Communication environment

- Half duplex asynchronous
- Parity: No parity
- Stop bit: 1 stop bit
- Communication method: RS232 or RS485 (optional)
- Communication speed: 4800/9600/19200/38400 bps (optional)
- Communication cable: refer to the cable wiring diagram
- Number of PLCs on a single network: Maximum of 64 (communicating 1:N using RS485)
- Maximum communication delay time: 3 seconds

Communication Protocols

Step 1-Q

Query

Q (Query) is a signal sent from the peripheral devices to the PLC after setting the network ID number and the function code for the PLC to communicate with.

Step 2-QA

Query Acknowledge

QA (Query Acknowledge) is a signal sent from the PLC to the peripheral devices, indicating that the Q signal from the peripheral device was received.

Step 3-RR

Response Request

RR (Response Request) is a signal sent from the peripheral device to the PLC, indicating that the QA signal from the PLC was received. This signal is sent when Q-QA is normal.

Step 4-R

Response

When the PLC receives the RR from the peripheral device, it determines that the communication with peripherals is successful and sends R (Response) signal to the peripherals. This R signal contains how the original Q signal from the peripheral device handled its function code. The communication cycle for one function code ends when the PLC sends the R.

Communications delay

The PLC will return a signal after receiving a Q or an RR within a specific time. However, due to errors in the communications network, CRC values, and communication speed flux, there are occasions when the PLC will not receive the signal from the peripheral device. The peripheral device should allow up to three seconds for a response from the PLC. If there are no responses to the Q or the RR message, the communication is considered to have failed, and the Q or RR should be sent again.

CPU ID

All devices connected to the network need a network ID number for communication. There is an available range of 0 to 191 network ID numbers for the NX series.

Redundancy is not permitted. When a single PLC and a peripheral device are connected, usually 0, 1, or 255 is assigned as the network ID number to the PLC. When the peripheral device wants to communicate to a connected PLC regardless of its programmed network ID number, it can use global network ID number 255, to which any PLC will respond. However, the NX series can not be used to communicate with more than two CPU modules at one time, so if you assign ID 225 as an ID of more than two CPU modules at once, it will cause communication errors.

When several CPU modules are connected to one communication network, they must use individual ID numbers. The PLC's network ID number is configured using the WinGPC.

Communication steps

The NX CPU can support 2-step or 4-step communication methods. The communication methods are easily distinguished each other by selecting and sending the function code of the Q frame. Even for the 4-step method, the 2-step method can be used for the repeated function. This function sends and receives the only RR repeatedly when you want to redo the frame you sent with query, allowing users to quickly monitor data.

- **2-step communication method**

This method allows users to easily and directly program communication since it only uses the simple $Q \rightarrow R$ steps.

2-step configuration:

$Q(\text{step } 1) \rightarrow R(\text{step } 2)$

Repeated function code:

$Q(\text{step } 1) \rightarrow R(\text{step } 2) \rightarrow RR(\text{step } 1) \rightarrow R(\text{step } 2) \rightarrow$

$RR(\text{step } 1) \rightarrow R(\text{step } 2) \dots$

- **4-step communication method**

$Q \rightarrow QA \rightarrow RR \rightarrow R$.

2-step method can be used for the response to the repeated function code.

4-step configuration:

$Q(\text{step } 1) \rightarrow QA(\text{step } 2) \rightarrow RR(\text{step } 3) \rightarrow R(\text{step } 4)$

Repeated function code:

$Q(\text{step } 1) \rightarrow QA(\text{step } 2) \rightarrow RR(\text{step } 3) \rightarrow R(\text{step } 4) \rightarrow$

$RR(\text{step } 1) \rightarrow R(\text{step } 2) \dots$

2-step communication method

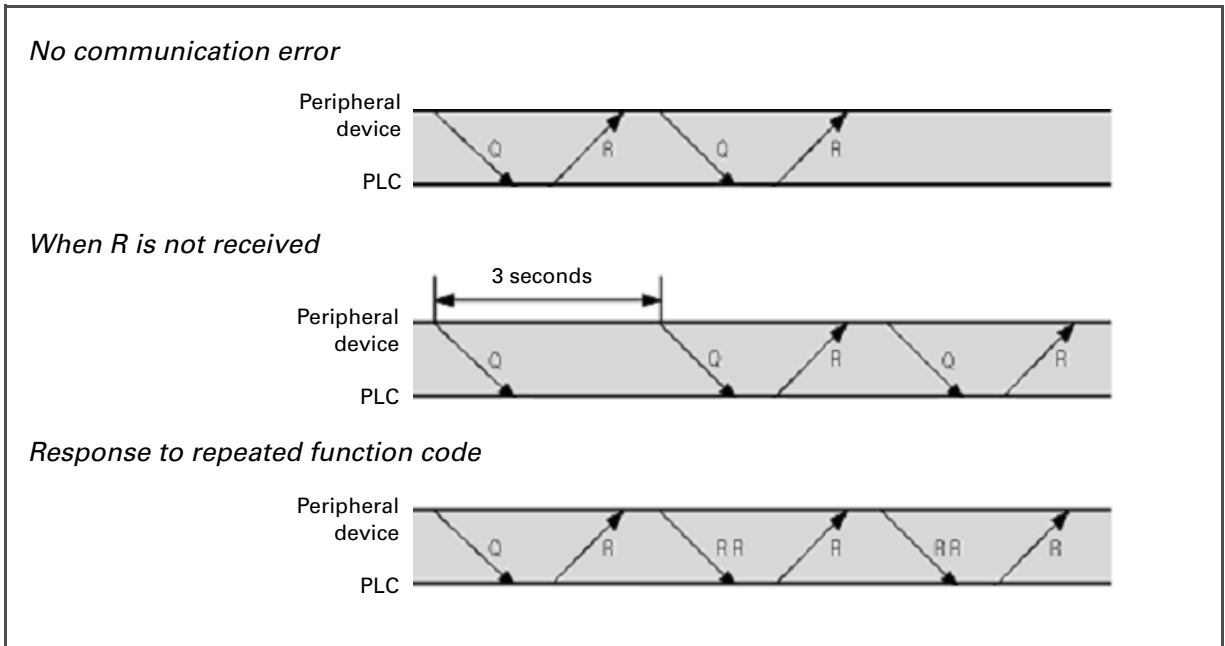

4-step communication method

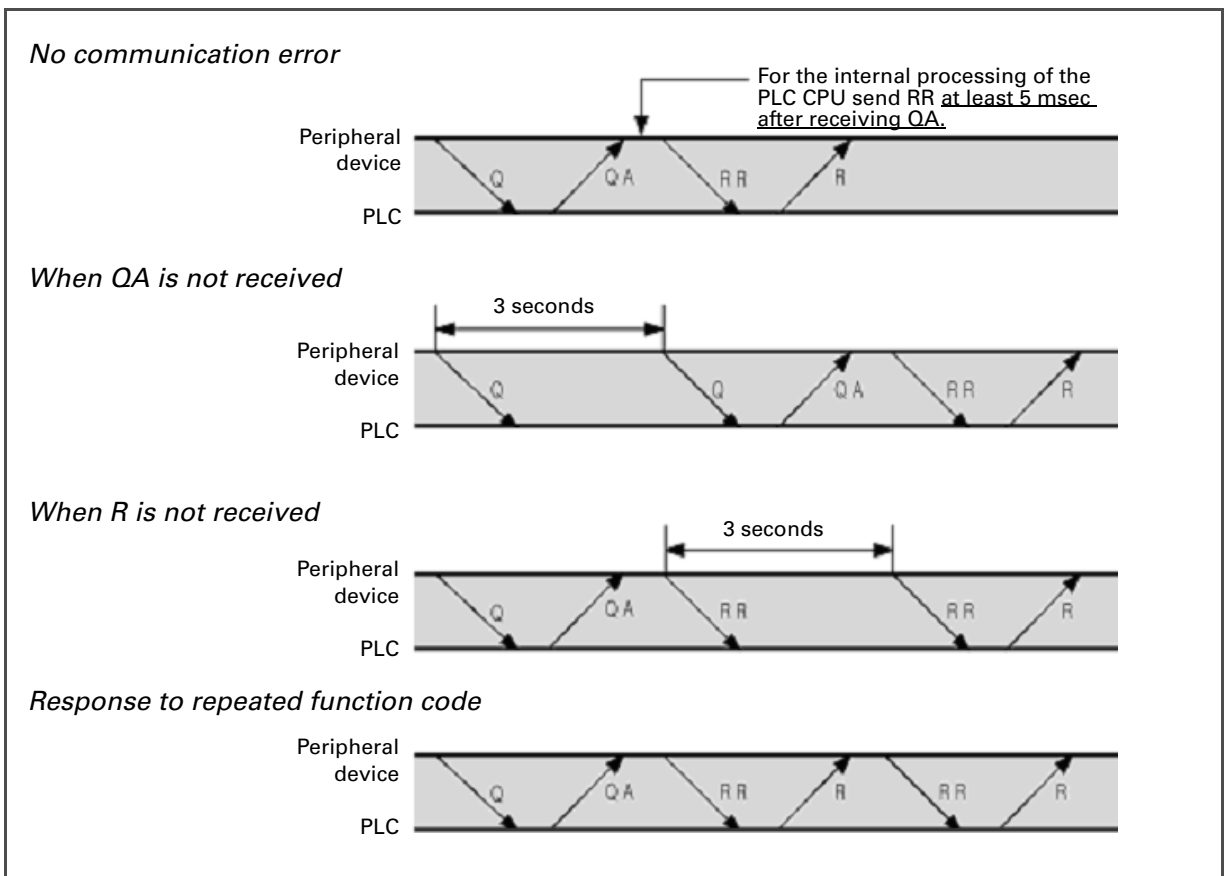

Function codes included in the query

Each function code is 1 byte. When the PLC receives a query (Q), the function code of the final response (R) is formed by adding \$80 (hex) to the function code sent by the query. The value added to the function code sent by the query differs for 2-step and 4-step by \$20 (hex).

The function code of the R message can be used by the peripheral device to verify that the correct Q message has been received by the PLC.

Communication function codes

\$ notes hexadecimal notations

Communication function	Query (Q) function code		Response (R) function code		Remarks
	2-step	4-step	2-step	4-step	
Read bits	\$21	\$01	\$A1	\$81	Detailed description
Write bits	\$22	\$02	\$A2	\$82	"
Read words	\$23	\$03	\$A3	\$83	"
Write words	\$24	\$04	\$A4	\$84	"
Read bits and words	\$25	\$05	\$A5	\$85	"
Write bits and words	\$26	\$06	\$A6	\$86	"
Read program	\$27	\$07	\$A7	\$87	No detailed description
Write program	\$28	\$08	\$A8	\$88	"
Read instruction	\$29	\$09	\$A9	\$89	"
Change instruction	\$2A	\$0A	\$AA	\$8A	"
Change operand	\$2B	\$0B	\$AB	\$8B	"
Insert instruction	\$2C	\$0C	\$AC	\$8C	"
Delete instruction	\$2D	\$0D	\$AD	\$8D	"
Search instruction	\$2E	\$0E	\$AE	\$8E	"
Search operand	\$2F	\$0F	\$AF	\$8F	"
Delete all/parts of program	\$20	\$10	\$A0	\$90	"
No service	\$00	\$00	\$00 (hex)	\$00 (hex)	"

The bit/word address assignment uses the absolute address method for reading memory locations. (Refer to [Absolute Addressing on Chapter 3](#))

Please contact our technical support for more information about reading/writing program or other function codes.

Query, which dictionary meaning is `question`, `ask`, or `question mark`, means that a user or an application program requests any specific information to a corresponding part when it is used as a communication term.

Cyclic Redundancy Checking (CRC)

The CRC is a 2-byte checksum code attached to the end of the message by the sender to check if the communication frame is transmitted without error.

The sender calculates the CRC when it sends one-byte message, and the receiver should also calculate the CRC from the data of the message. Since this CRC calculation takes a long time when writing a communication program, you should find any ways to increase the speed of this part to avoid errors and improve the communication speed.

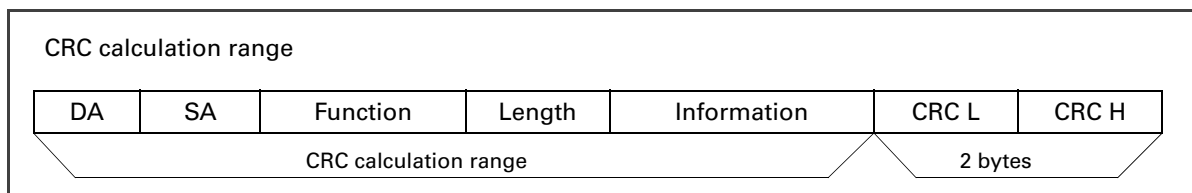

CRC-16 calculation subroutine written in BASIC

```
CRC_Sum: CRC-16 reserve code after the calculation (CRC content to be sent at the
end of message)
Data: CRC-16 data input to be calculated (byte data from message)

1000 CRC_Sum = CRC_Sum XOR Data
1010 FOR I=1 to 8
1020 CARRY=CRC_Sum AND 1
1030 RC_Sum=CRC_Sum SHR 1
1040 IF CARRY=1 THEN CRC_Sum XOR 0A001H
1050 NEXT I
1060 RETURN
```

CRC-16 calculation subroutine written in PASCAL

```
Procedure CRC16 (Data: Byte)
  Var i : Byte;
Begin
  CRC_Sum := CRC_Sum xor Data;
  for i : 1 to 8 do
  Begin
    if((CRC_Sum and 1)=1) then CRC_Sum := (CRC_Sum shr 1) xor $A001;
    Else CRC_Sum:= CRC_Sum shr 1;
  End;
End;
```

CRC-16 calculation subroutine written in C

```
Void Crc16 (unsigned int Data) {
  Unsigned int i;
  Crc=Crc^(Data & 0x00FF);
  for(i=0;i<=7;i++) {
    if((Crc & 0x0001) == 0x0001) Crc=(Crc>>1)^0xA001;
    else Crc=Crc>>1;
  }
}
```

Structure of Communication Frames

The function code is explained with the example of Query and Response frame based on the 2-step communication.

Query (Q) and Response (R) frame

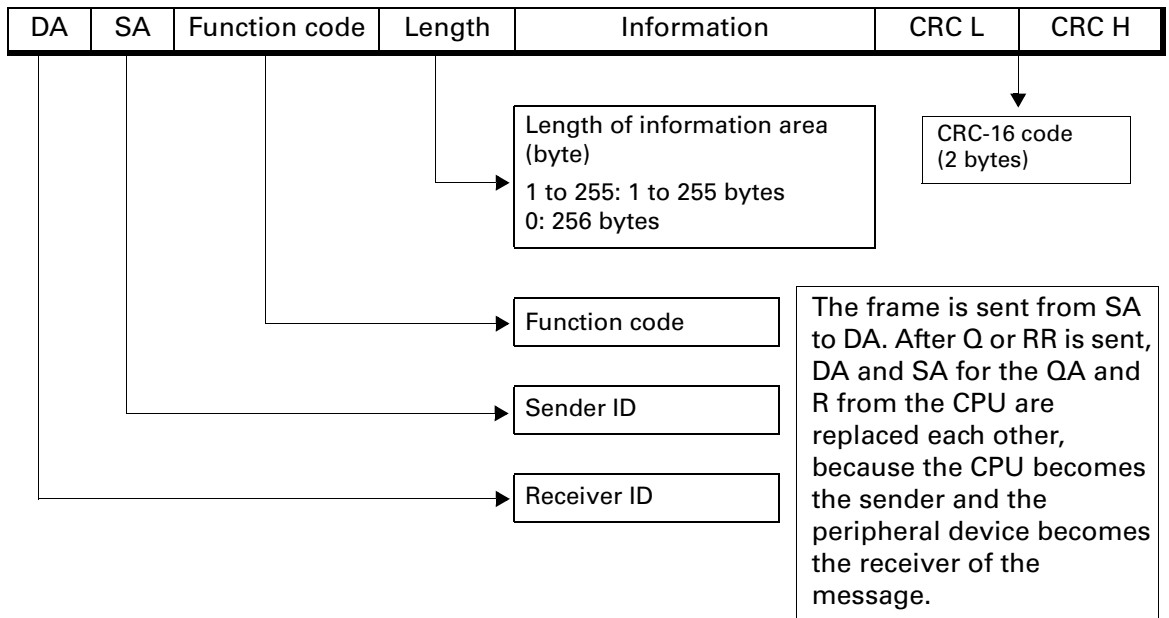

Query Acknowledge (QA) frame

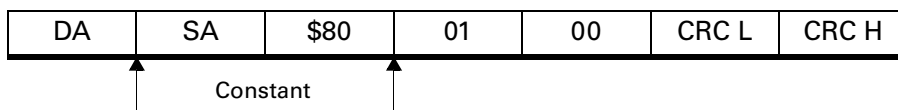

Response Request (RR) frame

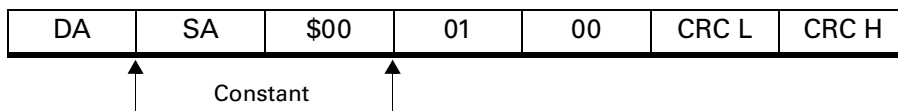

Response (R) frame for an error

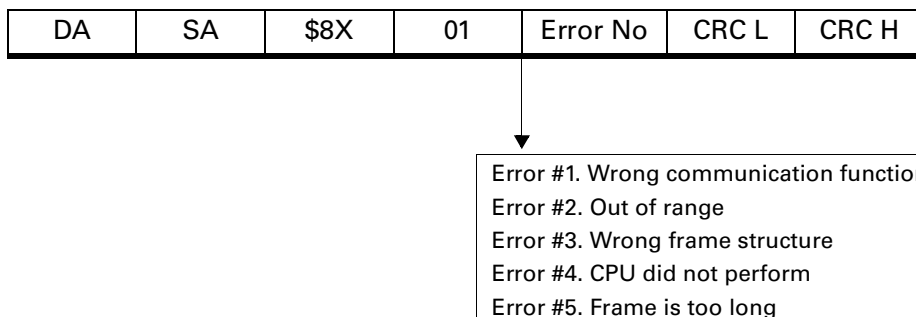

Read bits

Read the content of the bits (R, L, M, K, F, or TC) assigned to the absolute address.
Can read n consecutive bits (On/Off).

Query (Q) frame

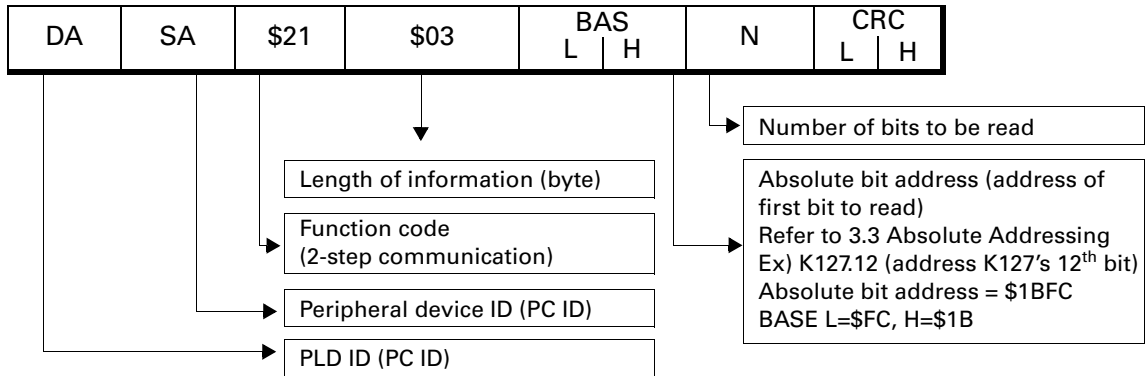

Response (R) frame

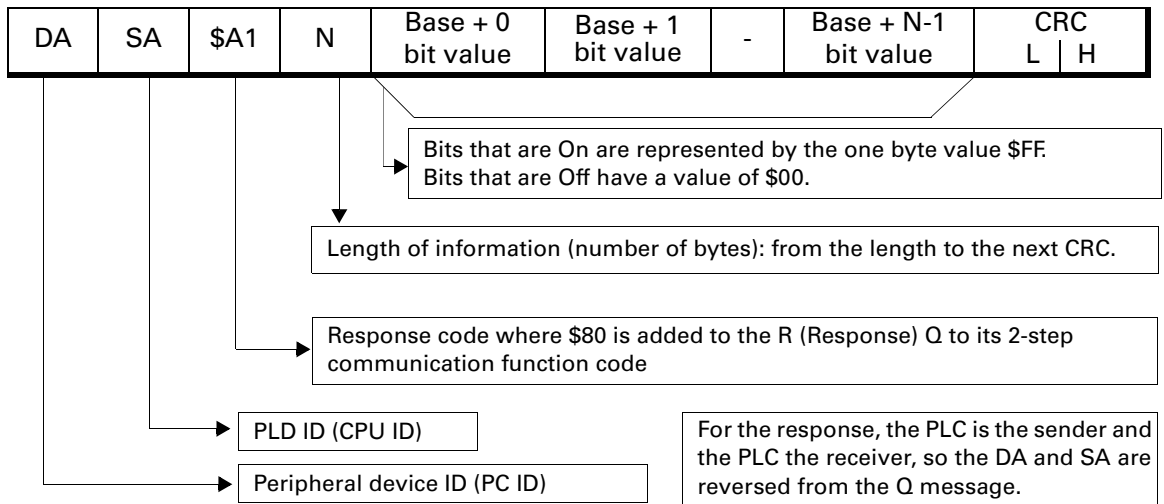

Write bits

Modify the contents of the bits stored in the absolute address (R, L, M, K, F, or TC).
 Change the bit state between On/Off.
 Can change multiple consecutive bytes.

Query (Q) frame

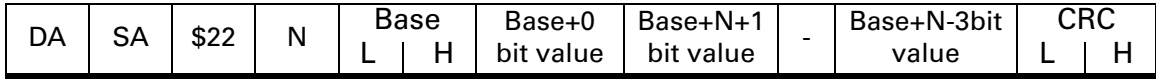

To turn On the desired bit value from the base, enter \$FF.
 To change to Off, enter \$00.

Absolute bit address (starting address)
 Refer to [Absolute Addressing on Chapter 3](#).

Response (R) frame

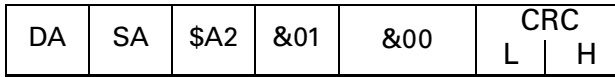

Fixed

Completion code

Read words

Read the content of the words (R, L, M, K, F, or W) assigned to the absolute address.
 Can read n consecutive words.

Query (Q) frame

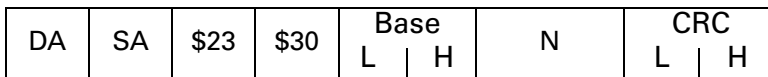

Number of words to be read

Word absolute address (starting address)
 Refer to [Absolute Addressing on Chapter 3](#).
 Ex) Absolute address of K127 word is \$01BF.
 BASE L=\$BF, H=\$01

Response (R) frame

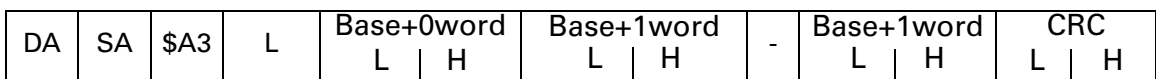

N word values from the base words requested by the Q.

Length L = Nx2

Write words

Change the content of the words (R, L, M, K, F, or W) assigned to the absolute address.
Can read n consecutive words.

Query (Q) frame

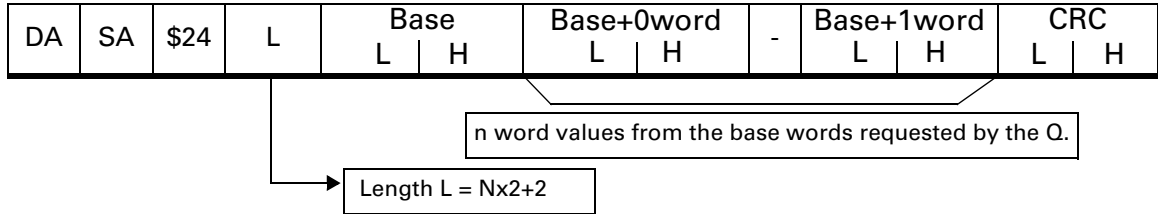

Response (R) frame



Read bits and words

Read the bits and/or word contents of the assigned absolute addresses.
Can read bits and words regardless of their order and location in memory.

Query (Q) frame

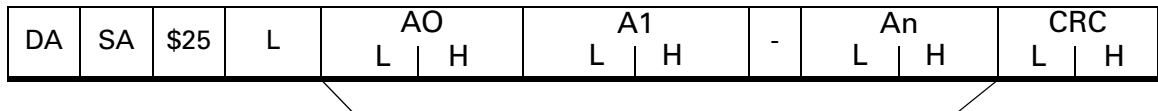

<p>Method of assigning bit/word absolute address</p> <table style="width: 100%; border-collapse: collapse;"> <tr> <td style="width: 10%; text-align: right;">15</td> <td style="width: 10%; text-align: right;">14</td> <td style="width: 10%; text-align: right;">13</td> <td style="width: 10%;"></td> <td style="width: 10%; text-align: right;">0</td> </tr> <tr> <td style="border: 1px solid black; width: 10%;"></td> <td style="border: 1px solid black; width: 10%;"></td> <td colspan="3" style="border: 1px solid black; text-align: center;">Absolute Address(Bit/Word)</td> </tr> </table> <p>0 0 Absolute bit address 0 1 Absolute word address 1 X Not used Ax=A0, A1, ..., An Dx=D0, D1, ..., Dn</p>	15	14	13		0			Absolute Address(Bit/Word)			<p>Assigning absolute address for bits Absolute address for the K127 12th bit =\$1BFC Ax=0001 1011 1111 1010 Ax L=\$FC, H=\$1B</p> <p>Assigning addresses for word Absolute address for the K127 word =\$01BF Ax=0100 0001 1011 1111 Ax L=\$BF, H=\$41</p>
15	14	13		0							
		Absolute Address(Bit/Word)									

Response (R) frame

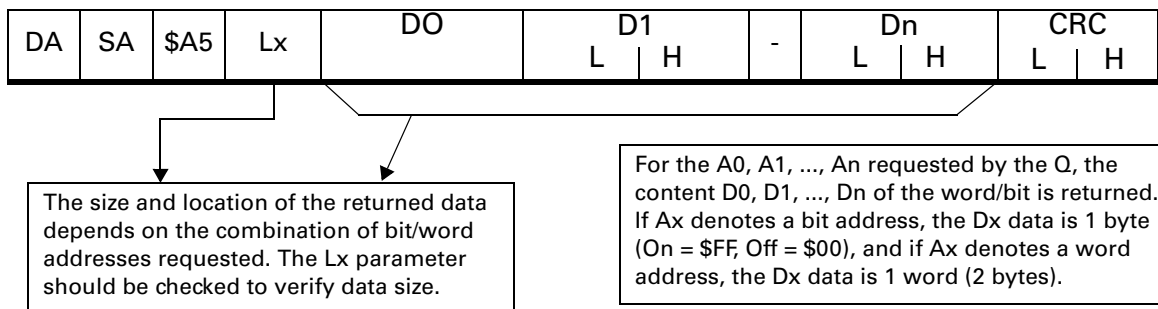

Communication Program Examples

Users can write a communication program by using the following example. For more information, contact the sales or technical department.

Program	Notes
<pre> <PLC communication sample code> #include <stdio.h> #include <dos.h> #include <conio.h> #define PC_ID 0xE2 #define time_limit 28 #define retrial_limit 2 #define TRUE 1 #define FALSE 0 #define lower_byte(x) ((x)& 0x00FF) #define upper_byte(x) (((x)& 0xFF00)>>8) typedef int BOOL; unsigned int PORTADD,DIVISOR,sending_delay, receiving_delay; unsigned int sending_frame[262],receiving_frame[262]; unsigned int Crc; unsigned int card,i,ix,iy,smode; unsigned int port_number; unsigned int PlcID,OldID; BOOL Success; unsigned int data,JobID,retrialC; unsigned int Old,New,receiving_Index_max,sending_Index_max, index,watchdog; unsigned int M[128],K[128]; /* Example Register */ void RR_occurring(void); void Trsport(unsigned int); unsigned int Recport(void); BOOL sending_occurring(void); BOOL receiving_occurring(void); void Crc16(unsigned int); void Job(void); unsigned int communication(void); void Mword_reading(void); void Kword_writing(void); void main(void) { unsigned int i; /* Selection of communication port */ clrscr(); printf("PORT : COM1[1]/ COM2[2]/ GPC-232[3]/GPC-485[4]/GPC- Parallel[5] = "); scanf("%d",&port_number); if ((port_number < 1) (port_number > 5)) port_number=5; /* Selection of Baudrate for Serial communication */ sending_delay=10; if (port_number != 5) { printf("GPC card BAUD-RATE : 9600[1]/ 4800[2]/ 2400[3] = "); scanf("%d",&i); if ((i < 1) (i > 3)) i=1; if (i == 3) i=4; if ((port_number == 1) (port number == 2)) DIVISOR=12 * i; else DIVISOR=40 * i; receiving_delay=3 * i + 1; } </pre>	<p>This program was written in Borland C++. It uses the peripheral devices such as PC to read M000 to M127 words, stores them in the K000 to K127, and then compares the two registry values and indicates the results on the screen using the OK or the FAIL notation. The user may read or manipulate the various communication function codes and the sent/ received information to control the PLC in various ways.</p> <p>This program consists of a header, the main program, and various functions. The buffers and variables needed to store the communication data are set as global variables, so that the main and various other functions may reference them.</p> <p>By using the COM1 and COM2 ports of the computer, serial communication is possible. By using the GPU-300 card, parallel communication is also enabled.</p> <p>The Qs, QAs, RRs, and Rs are handled in the job function. If there is any communication delay or frame breakdown, retry 3 times, then issue a communication error.</p> <p>The procedure of the communication, according to the JobID is:</p> <ol style="list-style-type: none"> 1.Q sending 2.QA receiving 3.RR sending 4.R receiving <p>When an error occurs in a frame, a retransmission should be made.</p> <p><Main operations of the program></p> <ol style="list-style-type: none"> 1. Adjusts the initial communication port and the board rate for communication. Then initializes the variables. 2. Using the communication function codes, reads the data of the M field, reads the word values of the M0 to M127 word area. The K registers are the retentive registers. 3. Uses the communication code to read the data of the K area. 4. Compares the values of the M area and the values of the K area, and indicates OK when the values are the same. <p>Beginning of the main program</p> <p>Select the port of the peripheral device for the communication.</p> <ul style="list-style-type: none"> Serial 9 pins, 25 pins Parallel GPU-300 parallel port <p>Select board rate:</p> <ul style="list-style-type: none"> 9600 bps (max): 4800 bps 2400 bps <p>Set the communication environment (delay time) for the selected ports.</p> <p>Note: GPC-300 card port address = 0x0300</p>

Program	Notes
<pre> * Initialization of GPC card */ if(port_number == 1) PORTADD=0x3F0; if(port_number == 2) PORTADD=0x2F0; if ((port_number >= 3) && (port_number <=5)) { PORTADD=0x300; outputb(0x303,0xC0);/* Mode=2 of 8255 */ outputb(0x303,0x05);/* PC2=1 of 8255 :Disable IRQ2 */ outputb(0x301,0xFF);/* PB0=1 of 8255 :Sending Enable RS- 485*/ outputb(0x303,0x01);/* PC0=1 of 8255 :Serial Input Enable*/ if(port_number == 3) outputb(0x303,0x02);/* PC1=0 of 8255 :Select RS-232 */ if(port_number == 4) outputb(0x303,0x03);/* PC1=1 of 8255 :Select RS-485 */ if(port_number == 5) outputb(0x303,0x00);/* PC0=0 of 8255 :Disable SerialInput*/ } else outputb(PORTADD+0x09,(inportb(PORTADD+0x09)&0xF0));/ *Disable Interrupt*/ /* Initialization of USART-Chip : 8250 */ if (port_number != 5) { outputb(PORTADD+0x0B,0x80);/* Set of DLAB=1 */ outputb(PORTADD+0x09,0x00);/* Set of High Byte DIVISOR */ outputb(PORTADD+0x08,DIVISOR);/* Set of Low Byte DIVISOR */ outputb(PORTADD+0x0B,0x03); /* Parity=None/Stop=1/ Length=8 */ } /* Processing communication of Read & Write */ for(; ;) { printf("-----\nPLC-ID (CPU ID) :"); scanf("%d",&PlcID); Mword_reading(); Kword_writing(); } } void RR_occurring(void) { receiving_frame[2]=0; receiving_frame[3]=1; receiving_frame[4]=0; } void Trsport(unsigned int data) { if (port_number == 5) outputb(PORTADD,data); else outputb(PORTADD+0x08,data); } unsigned int Recport(void) { unsigned int dt; if (port_number == 5) dt=inportb(PORTADD); else dt=inportb(PORTADD+0x08); return(dt); } BOOL sending_occurring(void) { BOOL tf; if (port_number == 5) tf=((inportb(PORTADD+0x02) & 0x80)==0x80); else tf=((inportb(PORTADD+0x0D) & 0x20)==0x20); return(tf); } BOOL receiving_occurring(void) { BOOL rf; if (port_number == 5) rf=((inportb(PORTADD+0x02) & 0x20)==0x20); else rf=((inportb(PORTADD+0x0D) & 0x01)==0x01); return(rf); } void Crc16(unsigned int data) { unsigned int i; Crc=Crc^(data & 0x00FF); for(i=0;i<=7;i++) { if((Crc & 0x0001) == 0x0001) Crc=(Crc>>1)^0xA001; /* 0x0001 : multi-nominal expression */ else Crc=Crc>>1; } } </pre>	<p>GPC-300 card Setting (8255chip setting) Uses the communication card that is connected, and sets the environment according to the PLC communication specifications, so that communication is possible.</p> <p>CPU-ID: Input PLC ID (0 to 255)</p> <p>Reads the register value for the M area (M0 to M127) Stores the value for the M area in the K area. (K0 to K127)</p> <p>RR (Request Response) request function</p> <p>Sends data to the communication port.</p> <p>Reads the received data from the communication port.</p> <p>Outputs the data when a Send event occurs..</p> <p>Inputs the data when a Receiver event occurs.</p> <p>CRC calculation Encodes the communication data in the byte stream. Any completed communication function will be attached to the latest frame or will be compared with the attached CRC to check for data errors. (Note: The CRC method can be implemented in several ways within the rule specified as shown in the left code.)</p>

Program	Notes
<pre> void Job(void) { /* JobID=0 : Change to sending-mode for serial port */ /* JobID=1 : Transmit sending-frame */ /* JobID=2 : Change to receiving-mode for serial port */ /* JobID=3 : Address polling of ACK from CPU */ /* JobID=4 : Receive ACK from CPU */ /* JobID=5 : Change to sending-mode for serial port */ /* JobID=6 : Transmit RR-Frame */ /* JobID=7 : Change to receiving-mode for serial port */ /* JobID=8 : Address polling of RES from CPU */ /* JobID=9 : Receive RES from CPU */ /* JobID=10 : Success communication processing */ switch(JobID) { case 0: case 5:if (port_number != 5) { if (port_number == 4) outportb(0x301,0xFF); else outportb(PORTADD+0x0C,(inportb(PORTADD+0x0C) 0x02)); delay(sending_delay); } if (JobID == 5) RR_occurring(); watchdog=0; index=0; sending_Index_max=5; Crc=0xFFFF; JobID++; break; case 1: case 6:if (receiving_occurring()) data=Recport(); if (sending_occurring()) { if (index<sending_Index_max-1) { Trsport(receiving_frame[index]); Crc16(receiving_frame[index]); if (index==3) { if (receiving_frame[3]==0) sending_Index_max=256+5; else sending_Index_max=receiving_frame[3]+5; } } else if (index==sending_Index_max-1) { receiving_frame[index]=lower_byte(Crc); Trsport(receiving_frame[index]); } else if (index==sending_Index_max) { receiving_frame[index]=lower_byte(Crc); Trsport(receiving_frame[index]); } else if (index==sending_Index_max) { receiving_frame[index]=upper_byte(Crc); Trsport(receiving_frame[index]); watchdog=0; JobID++; }; index++; } break; case 2: case 7:if (port_number != 5) { delay(receiving_delay); if (port_number ==4) outportb(0x301,0x00); else outportb(PORTADD+0x0C,(inportb(PORTADD+0x0C) & 0xFD)); } JobID++; break; case 3: case 8:if (receiving_occurring()) { data=Recport(); if(data==PC_ID) { Crc=0xFFFF; index=1; receivingIndexmax=5; receiving_frame[0]=data; Crc16(data); JobID++; } } } } </pre>	<p>Communication sequence function</p> <p>JobID=0 to 4: handle Q and QA frames JobID=5 to 9: handle RA and R frames</p> <p><u>JobID 0,5:</u> A frame that sends the data from the peripheral device to the PLC. It resets the watchdog and the CRC. Use a delay after the send to avoid errors due to communications delays.</p> <p><u>JobID 1,6:</u> Sends the Q and RR data. When there is no error, it resets the watchdog and proceeds on to the next sequence.</p> <p><u>JobID=2,7:</u> A sequence that senses the sending of the QA and R data to the peripheral device after the completion of the functions that are received by the PLC from the previous frame.</p> <p><u>JobID=3,8:</u> Handles the received data, and calculates the CRC of the received data.</p>

Program	Notes
<pre> break; case 4: case 9:if(receiving_occurring()) { if(index<receiving_Index_max-1) { receiving_frame[index]=Recport(); Crc16(receiving_frame[index]); if(index==3) { if(receiving_frame[3]==0) receiving_Index_max=256+5; else receiving_Index_max=receiving_frame[3]+5; } } else if(index==receiving_Index_max-1) { receiving_frame[index]=Recport(); if(receiving_frame[index]!=lower_byte(Crc) JobID=(JobID & 0x05); } else if(index==receiving_Index_max) { receiving_frame[index]=Recport(); if(receiving_frame[index]==upper_byte(Crc) JobID++; else JobID=(JobID & 0x05); }; index++; } } break; case 10:Success=TRUE; } } } unsigned int communication(void) { struct time t; unsigned far *tm; int ret; Success=FALSE; receiving_frame[0]=PlcID; receiving_frame[1]=PC_ID; retrialC=retrial_limit; watchdog=0; JobID=0; index=0; sending_Index_max=5; Crc=0xFFFF; do { tm=(unsigned far *) 0x046C; New=*tm; Job(); if(watchdog>Time_limit) { watchdog=0; retrialC--; JobID=(JobID & 0x05); } }if(!(((Old^New) & 0x02)==0)) { watchdog=watchdog+1; Old=New; } }while((retrialC!=0) && (Success==FALSE)); if(retrialC==0) ret=1; else ret=0; return(ret); } void Mword_reading(void) { /* Example of Read-Register */ int i; receiving_frame[2]=3; /* EXAMPLE READ WORD(M000-M0127) */ receiving_frame[3]=3; /* Number Of Byte For Information = 3 */ receiving_frame[4]=0xC0; /* BASE(M000=\$00c0) */ receiving_frame[5]=0; /* BASE HIGH */ receiving_frame[6]=128; /* Number Of Byte M000-M127 */ if(communication() == 0) { printf("READ M000-M0127 OK\n"); for(i=0;i<=127;i++) M[i]= receiving_frame[i*2+4] + receiving_frame[i*2 +5]*256; } else printf("communication error\n"); } void Kword_writing(void) { /* Example of Write-Register */ int i; receiving_frame[2]=4; /* EXAMPLE write WORD(K000-K063) */ receiving_frame[3]=130; /* Number Of Byte For Information */ receiving_frame[4]=0x40; /* BASE(K000=\$0140) LOW */ receiving_frame[5]=1; /* BASE HIGH */ for(i=0;i<=63;i++) { receiving_frame[i*2 +6]= lower_byte(K[i]); receiving_frame[i*2 +7]= upper_byte(K[i]); } } </pre>	<p><u>JobID=4,9:</u> Stores the received data in the internal receive buffer and compares the CRC value sent by the PLC to the calculated CRC value. It notifies the system that a successful communication is made when the two values match, and proceeds on to the next sequence.</p> <p><u>JobID=10:</u> Notifies the successful sending and receiving</p> <p>If the frames that were sent have no response within 3 seconds, assumes it failed communication, and retransfers the data. The time from the sending and receiving is counted using the watchdog timer. Resets the watchdog time when a retransfer is being made. No response after 3 transmissions indicates a communication error. (Normal return value = 0, Abnormal return value = 1)</p> <p><i>Reading function of the M register</i> Uses the communication function code 3 (reading N consecutive words) to read the M area. Note: Sending frame [4] = The lower byte of the absolute address of the words to be read. Sending frame [5] = The upper byte of the absolute address of the word to be read. Absolute address of M0 = 0x0C0 Note: Sending frame [6] = The number of words to be read. Sends a function code requesting to read the M area, and stores the received data in the buffer.</p> <p><i>Writing Function of the K Register</i> Uses the communication function code 4 (writing N consecutive words) to store the specified value in the K000 to K063 word. Note: Absolute address of K0 = 0x0140</p>

Program	Notes
<pre> if(communication() == 0) printf("WRITE K0000-K0063 OK\n"); else printf("communication error\n"); receiving_frame[2]=4; /* EXAMPLE write WORD(K064-K0127) */ receiving_frame[3]=130; /* Number Of Byte For Information */ receiving_frame[4]=0x80; /* BASE(K000=\$0180) LOW */ receiving_frame[5]=1; /* BASE HIGH */ for(i=0;i<=63;i++) { receiving_frame[i*2 +6]= lower_byte(K[i+64]); receiving_frame[i*2 +7]= upper_byte(K[i+64]); } if(communication() == 0) printf("WRITE K0064-K0127 OK\n"); else printf("communication error\n"); } </pre>	<p><i>Writing function of the K Register</i> Uses the communication function code 4 (writing N consecutive words) to store the specified value in the K064 to K127 word.</p> <p>Note: Absolute address of K64 = 0x0180</p>

NX70 Series Programmable Controllers NX70-CPU70p1 and NX70-CPUp2 User Manual

www.samsungautomation.co.kr

Rockwell Samsung Automation

447-6, Gongse-Ri, Giheung-Eup, Youngin-City,
Gyeonggi-Do, South Korea, 449-902

Tel: 82-31-280-4700 Fax: 82-31-280-4900

Technical Support

Export Sales Team

Tel: 82-31-280-4768 Fax: 82-31-280-4900

Trademarks not belonging to Rockwell Samsung
Automation are property of their respective companies.

Publication RSA-NX70-UM003A-EN-P - March 2005

Copyright © 2005 Rockwell Samsung Automation. All rights reserved. Printed in Korea.